

LED Street Lighting  
DC-Microgrids  
LED Signage Driver  
Thermal Management  
LED Investor Forum



FREE EDITION  
**CLICK HERE NOW**  
to see why you  
should upgrade  
to the  
FULL VERSION

# THE LATEST AND GREATEST LED LIGHTING

- > A world of 10,000 LED lighting components and design solutions
- > LEDs, Power and Thermal management, Interconnect and Optic products available
- > Global portfolio of industry leading manufacturers



[www.farnell.com/lighting](http://www.farnell.com/lighting)

element14

[www.element14.com](http://www.element14.com)



Design with the best



# A Guideline for Street Lighting

As an emerging technology, LED street lights have yet to experience major market penetration. On the other hand, cost reductions and performance improvements are continuing to increase LED street lighting viability. Lighting, energy, and economic performance will all be important factors in LED street lighting developments.

The high initial cost of LED street lights has been a challenge, but energy savings and projected maintenance cost savings through the luminaire lifetime both improve LED street light economics. Recent studies showed energy reductions ranging from 50% to 70% over current HPS systems.

But there are some legal, technological and application questions that arise with the use of LEDs for street lighting. These questions have to be carefully considered when entering this segment of the market. LED professional had the chance to speak with Prof. Tran Quoc Khanh, who is a professor at the University in Darmstadt, Germany and one of the leading street lighting experts, worldwide.

We explored the following topics: What is the legal situation in regards to the existing standards? Can we save additional energy with LED lights due to the differences between the mesopic and the scotopic visibility? What has been identified when using pulsed LED light in traffic applications? How should an intelligent LED street light be designed? What are the boundaries for the use of solar-powered street-lights and are hybrid systems the future?

The answers from Professor Khanh were surprising and I'm sure his insights into the topic of street-lighting will serve as a useful guideline for your own thoughts and product concepts for the street-lighting market.

The *LED professional Symposium +Expo 2011* (27-29 Sept.) is really gaining momentum. First class presentations will provide you with new insights into LED lighting. You will meet the Leaders in LED lighting in an extraordinary exhibition area in the Bregenzer Festspielhaus (James Bond film location) and you will be able to discuss your topics with the experts. A great chance to build and expand your networks! Take advantage of the Early Bird bonus and reserve your ticket now. We are very excited about the chance of meeting you personally in Bregenz and supporting you with winning approaches in LED lighting.

The complete program is available now at [www.lps2011.com](http://www.lps2011.com) for downloading.

We would very much appreciate your feedback about *LpR*. Let us know what you like or tell us how we can improve our services. Please keep in mind that you are also welcome to contribute your own editorials.

Yours Sincerely,

Siegfried Luger  
Publisher

# Content

■	Editorial	p 1	COMMENTARY	p 4
	Imprint	p 60	News - PROJECTS	p 5
			News - PRODUCTS	p 6
			News - RESEARCH	p 21
			CORRECTION	p 24

■	<b>EVENT</b>			
	LED Investor Forum 2011 - Santa Clara			p 26
	by Alan R. Miles, LED professional			

■	<b>INTERVIEW</b>			
	LED Street Lighting -			p 30
	About Standards, Challenges and Misconceptions			
	Interview with Prof. Tran Quoc Khanh, TU Darmstadt			
	by Siegfried Luger and Arno Grabher-Meyer, LED professional			

■	<b>APPLICATION</b>			
	DC Microgrids and SSL -			p 34
	Key Components for Zero Net Energy Buildings			
	by Brian T. Patterson, EMerge Alliance and Karen Lee, Osram Sylvania			

■	<b>ELECTRONICS</b>			p 40
	LED Driver Innovations for High-Performance Signage			
	by Roland Gehrman, Toshiba Consumer & Industrial ICs			

■	<b>THERMAL</b>			
	LED Cooling in Harsh Environments with Synthetic Jet Technology			p 44
	by Markus Schwickert and Brandon Noska, Nuventix			

	Thermal Management of LED Lamps			p 48
	by A.Motoya, M. Kai, Y. Manabe and S.Shida, Panasonic Corp.			

■	<b>SPECIAL TOPICS</b>			
	HB-LED Alert Device with Intense Light Output			p 54
	by Jerry Vereen, Egret Technologies			

## Advertising Index

Farnell	C2
LED professional Symposium	p 3
Lambda Research	p 7
Toshiba	p 9
LEDLink	p 11
Everlight	p 13
Instrument Systems	p 15
Edison	p 19
Signcomplex	p 23
Willighting	p 24
Recom	p 25
Vossloh-Schwabe	p 27
Carclo	p 29
Macroblock	p 29
Osram	p 33
Kingbright Electronic Europe	p 37
Taitronics	p 39
Fischer Elektronik	p 41
Micrel	p 43
OLED Lighting Design Summit	p 49
Curamik	p 51
euroLED	p 53
NEPCON Malaysia	p 53
LED light for you	p 55
Infineon	p 58
Lighting Fair Korea	p 59
Philips-Lumileds	C3
CREE	C4

**LED**  
professional

**SYMPOSIUM  
+EXPO**

**LpS 2011**

**EARLY BIRD BONUS  
SIGN UP NOW!**

[www.lps2011.com](http://www.lps2011.com)

# LED Lighting Technologies

International Winning Approaches

**27-29 SEPTEMBER 2011  
BREGENZ | AUSTRIA**

**CONTACT:**

LUGER RESEARCH | Faerbergasse 15 | 6850 Dornbirn  
T +43 5572 39 44 89 | F +43 5572 39 44 89 90  
[info@lps2011.com](mailto:info@lps2011.com) | [www.lps2011.com](http://www.lps2011.com)

**TRIDONIC**  
▼ enlightening your ideas

**OSRAM**  
Opto Semiconductors

**e:lumix**  
LED Technologie GmbH



**Herbert Resch**  
Lighting Expert, Founder  
and Business Manager of  
Symetrys

## APPLICATION OF LED TECHNOLOGY

LED technology creates new potential for product designs as well as the use of light for interior and outdoor architecture.

LED technology is a guarantee for resource conservation not only in energy consumption but also the using up of fossil fuels.

Technologically, it seems like what is possible is continuously increasing. The LED lumen/watt has reached the values of fluorescent lamps, and has, in some cases, even surpassed them. Color rendering (CRI) is at 98+, almost the same as a tungsten halogen lamp. Dimming LEDs without the color temperature changing is a standard, just like the generation of any imaginable light color by steering RGB model LEDs.

I think it is important, though, that new light and control system developments are oriented on implementation. Technology is defined by implementation and not the other way around.

LED technologies make it possible to create small, elegant light systems for use indoors as well as outside. We often see LED technologies integrated into outdated light housing in order to save the costs for tools needed to develop new design vocabulary. Not only is the aesthetic value lost, but also the advantages of miniaturization and/or resource optimization is not taken into consideration.

In this way, for example, the smallest high efficiency spotlights and wall washer systems for presentations and sales can be developed. Because LEDs don't generate any radiant heat, they are ideal if you don't want to damage the exclusive materials in a boutique.

Another, different example for the implementation oriented use of LED technology is the utilization of chips with a CRI value of 98 and more. This guarantees the best possible color rendering of works of art in museums, galleries and cultural buildings.

Lenses that have been calculated exactly, project focussed light on the work plane. "Light for Industry and Technology" increases productivity and guarantees safety as well as creating an attractive work place.

The application of high efficiency LEDs with precisely calculated lenses also minimize light smog and in some cases even eliminate it completely.

Who hasn't been bothered by "blinding" lanterns that shine into the living room or bedroom and interfere with perception as well as causing aggravating glare?

Intelligent LED systems create atmospheres in offices, schools and hospitals with technology that allows for steering the color temperature from 2800 K to 6600 K.

The quality of light is an important part of the quality of life. In the future, technological developments will allow innovative manufacturer systems to steer:

- Light direction (spot and flood)
- Light color (2800 K - 6600 K and the color spectrum)
- Light intensity

from one place. However, people will still be needed to choreograph architecture and space.

Ettore Sottsass:  
LIGHT NOT ONLY ILLUMINATES, IT TELLS A STORY. LIGHT IMPARTS MEANING, ILLUSTRATES METAPHORS AND CREATES THE STAGE FOR THE COMEDY OF LIFE. LIGHT ALSO TELLS THE STORY OF ARCHITECTURE.

H.R.

## Lumenal Brings New Sparkle to Christopher Evans Goldsmiths

Lumenal has fitted out jewelers Christopher Evans Goldsmiths in Poynton, Cheshire, with its premium quality LED lighting solutions to enhance the shelf appeal of merchandise on display. The Sirius strip lights and ceiling recessed Sol lamps were chosen as a more effective, durable and longer lasting alternative to conventional display lighting options.

**The largest benefits for this jewelry retailer are the quality of light output and the more comfortable store environment thanks to the lack of heat**



The flexible nature of LED lighting allowed Lumenal's expert engineers to manipulate the color of light emitted by their strip lights to ensure optimum illumination of the various metals and gemstones on display within each of the store's wall recessed and counter unit display cases. Warm white light was incorporated to make gold items appear lustrous, as well as neutral white light, which optimizes the appearance of silver and diamonds.

The superior diodes used within Lumenal's products will guarantee the consistency of the specially designed light colors, as well as brightness, throughout the lifetime of the fittings, which is expected to be in excess of 50,000 hours constant use. This remarkable lifespan, which is roughly equivalent to 10 years, assuming 85 hours trading per week, is a result of the fittings' expert design combined with their inherent resistance to shocks and vibrations. Their robustness eliminates the maintenance costs of replacing blown bulbs as well as the inconvenience of less effectively merchandised displays because of poorly illuminated cabinets.

**The Christopher Evans Goldsmiths in Poynton features Lumenal's LED ceiling recessed Sol lamps and Sirius strip lights**



A further advantage offered by Lumenal's lamps is their energy efficiency. They typically require 30-40% less energy than conventional fittings while providing the same or improved quality of light. This results in considerable savings in energy costs, which, in combination with the loss of maintenance costs, will provide Christopher Evans Goldsmiths a return on investment within 24-30 months.

Proprietor and chief goldsmith, Christopher Evans, comments on the success of the fit out: "There are two benefits in particular that have come from installing Lumenal's LED

**The Christopher Evans Goldsmiths in Poynton is now benefiting from the high performance of Lumenal's LED lights**



Lumenal's lighting produces little heat, removing the problem of an uncomfortably warm store environment, often experienced with conventional lighting, which usually emits a much larger amount of heat. This also means that the store's jewels will stay cool to the touch, making them more appealing to customers when handled. Lumenal's LED lights also remove the risk of packaging and display materials caused by ultra-violet light, which is emitted by conventional sources, but not LED lighting.

lighting. One is the quality of the light emitted by the fittings. They are far brighter than the conventional lights we had previously, and certainly bring our diamonds to life."

"Second, our main problem with the previous lighting was the amount of heat they emitted, which made the closed shop environment very uncomfortable for staff and customers, and incurred considerable running costs due to air conditioning requirements. As Lumenal's LED lighting emits significantly less heat, these problems no longer exist for us." ■

## ZEMOS LED Comes Up with New Patented ZEMOS 9090 Package for Extreme Capabilities

Patented in 2009, the ZemosLED Power Package uses advances in technology to significantly increase the life span of LEDs, the most energy efficient and longest lasting light source available. A result of three years of intense research and development by our engineers with over 20 years of LED experience, the ZemosLED Power Package has unprecedented thermal management capabilities.



**The new ZEMOS 9090 is a versatile high quality 3W white LED package**

### Features:

- Proprietary solid copper package with silver plating.
- High luminous flux, up to 130 lm/W
- Low thermal resistance of just 5 K/W
- Large 9mm x 9mm area effectively dissipates heat into underlying PCB
- Non-protruding lens of low viscosity silicon is less susceptible to damage, and puts less stress on bonding wires.
- Reflow solderable
- Available CRIs of 65 to 95
- Maximum recommended drive current of 1000 mA
- SiC based LED substrate
- Lifespan of up to 80,000 h with proper heat sinking

We rigorously test 100% of our power package products for a minimum of 72 hours. Our unique testing process includes boiling Zemos 9090 packages in an ink solution where defective LEDs are identified and discarded. This protocol eliminates any chance of leakage due to humidity and moisture that can penetrate other LEDs. As a result of stringent testing and superior quality, we ensure our LED's performance up

to 80,000 hours on applicable models that implement our ZemosLED Power Package. Other models in our line of products have a minimum life span of 50,000 hours.

- ZemosLED only uses materials that are 100% eco-friendly.
- They contain NO mercury or other hazardous materials which require proper disposal.

The Zemos9090 package disperses heat in the most effective manner to prevent a sudden rise in Junction temperature. ZemosLED is able to achieve this through state of the art thermal design of the LED package. Unlike conventional LED package structures that use a combination of an Epoxy resin cover and a thin copper slug, the entire substrate of the Zemos9090 package is pure, thermally-conductive copper. Therefore, Zemos9090 products disperse heat fast and efficiently, keeping junction temperatures steady.

Various tests, performed in different environmental settings, have demonstrated that it generally takes tens of thousands of hours for Zemos9090 LEDs to lose 30% of their Lumen output. Zemos9090's revolutionary thermal and optical designs easily meet LM80 test criteria. ZemosLED will soon publish LM-79 and LM-80 test results, along with EnergyStar certifications. ■

## Cree Delivers Brightest and Most-Efficient Lighting-Class LED Array

Cree, Inc., a market leader in LED lighting, announces full availability of the industry's first lighting-class LED array that help reduce overall system cost by combining superior efficacy, ease-of-design and ease-of-manufacture. The Cree XLamp® CXA2011 LED array is designed to deliver the smooth light output and consistent color needed for applications such as omnidirectional bulbs or directional downlights.

"The CXA2011 LED has been incredibly easy to work with, enabling us to create very high-performance products," said Jason Lee, president of Gama Illuminer. "It gave us a plug-and-play solution with the right combination of brightness, efficacy and color

consistency with real-world 85°C specifications. Creating a design with CXA2011 was simple and manufacturing will be underway in record time."

"Combining fast and flexible system design with ease-of-manufacturing, the CXA2011 LED array helps customers quickly create a broad range of LED-based designs," said Mike Watson, Cree senior director of marketing, LED components. "Lower system cost and quicker time-to-market are keys to accelerating the LED lighting revolution."



**Cree's new CXA2011 LED array helps to reduce system cost, to speed time-to-market and to simplify fixture and lamp design**

### Features:

- Available in ANSI white bins as well as 4-step and 2-step EasyWhite bins at 2,700K, 3,000K, 3,500K, 4,000K, 5,000K
- Forward Voltage: 40 V
- 85°C binning and characterization
- NEMA SSL-3 2011 standard flux bins
- Max drive current: 1,000 mA
- 120° viewing angle, uniform chromaticity
- Top-side solder connections
- Thermocouple attach point
- Screw down attachment
- RoHS and REACH-compliant
- Unlimited shelf life at  $\leq 30^{\circ}\text{C}/85\% \text{ RH}$

Easy-to-use screw-mounts simplify the manufacturing and design process by eliminating the need for complex design-specific engineering and reflow soldering. With the CXA2011, Cree leads the way on color accuracy by extending the industry's largest offering of LEDs characterized at real-world operating temperatures (85°C).

The CXA2011 LED array delivers up to 4,000 lumens at an operating temperature of 85°C (1A, 5,000 K) in a single component. It is available in 2-step and 4-step EasyWhite™ options, delivering the industry's tightest LED-to-LED color consistency—reducing system complexity and making light source selection as easy as specifying a color temperature. ■



# Top 10 Reasons to Buy TracePro

TracePro® Software - Design and Analyze any Optical/Illumination System



1. Easiest-to-use opto-mechanical software with full CAD integration
2. Simple Interactive Optimizer: sketch geometry, set variables, digitize targets, optimize
3. Lowest entry price for a permanent license
4. Multiple editions to fit your needs with upgrade path to help you with more complex problems
5. Our TracePro Bridge SolidWorks® add-in easily defines optical properties in your SolidWorks model
6. Multiple utility apps to digitize source, fluorescence, and surface scatter data
7. Multiple lens design and CAD import and export options with full CAD healing functionality
8. RepTile algorithms to define millions of repetitive surfaces, lenses, and textures
9. Outstanding visualization capabilities with interactive ray sorting and tables for incident rays, ray histories, and flux report
10. Trace billions of rays with 64-bit support and unlimited multi-threading

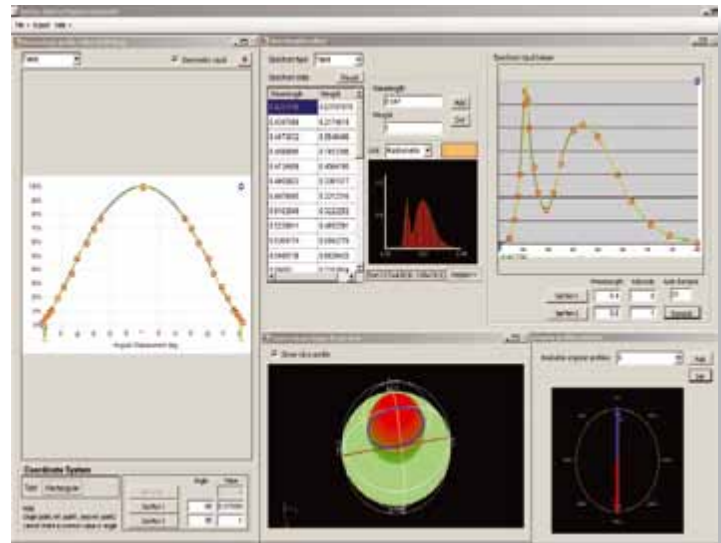

**Free  
Trial  
Offer!**

For a 30 Day Trial Offer Visit  
[www.lambdares.com/trials](http://www.lambdares.com/trials)



TracePro is a registered trademark of Lambda Research Corporation and SolidWorks is a registered trademark of Dassault Systemes

Lambda Research Corporation | 25 Porter Road, Littleton MA 01460 | (+1) 978-486-0766 | [www.lambdares.com](http://www.lambdares.com)

## New LUXEON H LED: High Voltage LED Uses Rectified AC

Philips Lumileds, a LED technology and market leader, continues to expand its LUXEON LED portfolio with its first high voltage emitter, LUXEON H. The new emitters are driven directly with rectified AC voltage rather than constant DC current. This high voltage architecture maximizes space for additional thermal management, permitting an increase in the thermal limit for even the smallest bulbs. The 50 Volt LUXEON H flexibly supports both 110 V and 240 V solutions.



**With the small footprint LUXEON H, Lumileds enters the high voltage LED market**

### Features:

- High voltage architecture maximizes space for thermal management
- Requires only a bridge rectifier and resistor, no DC driver
- ANSI compliant binning at CCTs of 2700 K and 3000 K
- Exceptional color stability over temperature and color current
- 50 V emitter supports 110 V and 230 V solutions
- Exceeds ENERGY STAR lumen maintenance requirements

### Benefits:

- Simplified solution for space constrained implementations
- Lower system costs
- High quality of light
- Exceptional color stability over temperature for real-world application performance and reliability
- High efficacy for sustainable lighting design
- Complete optical, electrical and mechanical design resources help you get to market faster

Designed to meet the demands of space constrained retrofit bulbs, LUXEON H emitters deliver industry leading thermal performance and reliability as well as high quality, warm white light. Two color temperatures are

available, 2700K and 3000K, with typical CRIs of 83. Typical flux is 84 lumens and 90 lumens respectively for the two correlated color temperatures. The new LUXEON H emitters are identical in footprint to the compact LUXEON Rebel and LUXEON Rebel ES LEDs further simplifying implementation.

“Our thin film flip chip technology allows us to continue to develop innovative solutions, like the multi-junction die in LUXEON H, for the illumination market,” said Frank Harder, VP of Product Marketing for LUXEON. “The base of some bulbs is so small that it’s impossible to fit both an electronic driver and a heat sink in the space. LUXEON H only requires a bridge rectifier and a resistor, both of which are very small, and the remaining space can be used for thermal management. And, because we don’t use direct red die like most other HV solutions, LUXEON H offers consistent, stable color from the instant the LED is powered and maintains its color through its lifetime.”

Initial uses of LUXEON H are expected in the retrofit bulb market where form factors for the bulbs are already defined and space is at a premium—especially so for the smallest bulb types ranging from the candelabra to the intermediate Edison, E10-E17 types. Philips Lumileds expects new solutions using LUXEON H to come to market during the second quarter of the year. ■

### Verbatim’s color changing OLED desk lamps at the Fuori Salone - Milan 2011



**Verbatim’s color changing OLEDs showing the color tuning capabilities**

## Verbatim Launches Color Tunable OLED Lighting

Verbatim has launched the world’s first commercially available, color tunable organic LED (OLED) lighting panels at the Fuori Salone show in Milan. The OLEDs are based on unique materials technology developed by Verbatim’s parent company, Mitsubishi Chemical Holding Group which, as one of the world’s major chemical companies, has over 50 years’ experience in developing lighting materials. Full-scale production of OLED panels will start in July.

Verbatim demonstrated the creativity and beauty of color tunable and white tone tunable OLED panels, thought to be the world’s largest at approximately 14 cm x 14 cm. Its display, created by lighting designer Satoshi Uchihara, was located in the Design Library srl, Via Savona 11, 20144 Milan.

The large surfaces of Verbatim OLEDs, branded VELVE, produce a soft light, free from glare and with deeply saturated colors. The OLEDs, which do not contain hazardous materials, are very efficient, producing 28 lumens per Watt output at 1000 cd/m<sup>2</sup> with accurate color rendering (high CRI). Color tuning and white tone tuning allow the mood

of a space to be varied to suit its function at the time. For example, it may be changed from a workspace requiring bright, cool light, to a place of relaxation with warm, subdued lighting.

The panels are designed for general lighting, furniture lighting and other applications. Verbatim sells the OLEDs directly to original equipment manufacturers (OEMs).

> **WE'RE CREATING A BRIGHTER FUTURE FOR EVERYONE.**

At Toshiba we make bright brighter with innovative products offering lower power consumption, longer operating life and a more compact form factor.

Our new range of high luminous flux transparent white LEDs achieve luminous efficacy values of 120 lm/W, and with a height of just 0.65mm, they are one of the industry's thinnest packages.

With our full line up of high efficiency, high output and high color rendering models, lighting designers in commercial, residential and industrial applications can contribute to reducing CO2 emissions and making the future brighter.

Visit us today at [www.toshiba-components.com/LEDS](http://www.toshiba-components.com/LEDS)



To simplify development work, Verbatim offers two products. A sample kit for architects, lighting designers and planners and development engineers contains an OLED that can be connected directly to the mains. It can be used to evaluate seven pre-programmed saturated colors, white tone tunability and a dimming function. Software control is implemented over a USB connection. The second product is an OLED module with a printed circuit board that provides an industry-standard DMX interface for RGB color control and a DALI interface for white tunability.

The OLED sample kit will be available in May 2011, and the OLED module during the second half of the year. ■

**Philips Introduces Fortimo LED SLM 3000 Module**

As well as a lifelong consistency of color temperature, the Fortimo LED SLM 3000 gives retailers new levels of freedom in display options. Closer illumination is now possible, thanks to reduced levels of UV and IR, and highly accurate dimmability (down to 10%) enables more creative and dynamic displays. Maximum punch is a key feature of this new product, with outstanding lumen output from a light source of less than 20mm making it ideal for high-end fashion stores and jewelry displays. "We believe we have broken new ground with this range extension, further closing the gap between LED spotlighting and traditional CHID lamps," says Wouter Boxhoorn, Segment Marketing Manager Retail OEM EMEA.



**Philips Lighting extended its range of LED spotlighting modules for the retail sector, with the introduction of the Fortimo LED SLM 3000**

Delivering 3,000 Lumen at more than 70 lm/W and a CRI above 80, the Fortimo LED SLM 3000 combines reduced energy use with the highest levels of crisp white light from a LED lamp, as well as unmatched flexibility in its class. With no re-lamping required, the Fortimo LED SLM 3000 also paves the way for minimum-maintenance lighting. And since it is fully InGaN-based technology, this LED spotlight module meets the toughest demands for stable white light, a key requirement in accent lighting for modern retail outlets. ■

**Several beams with high output ratio are available : 7.5°, 21°, 35°, 7.5°x37° as well as a zoomable system to offer further functionalities**



**Gaggione: Color Mixing Collimators for OSTAR SMT**

The highly efficient product line of 45mm diameter collimators provides excellent color mixing properties to address stage lighting, entertainment lighting architectural lighting application, and other applications looking for power and intensity with excellent cut-off and light efficiencies.

**Fields of Application:**

- Stage lighting
- Entertainment lighting
- Architectural lighting
- Floodlight for shop lighting
- Scientific/Instrumentation
- Signaling/Industrial

**Benefits:**

- Light output efficiency up to 90%
- Excellent color mixing property
- Sharp cut off with very narrow beam
- ZOOM alternative with secondary lens

The result of intense collaboration between LED lighting optical designers and some of the most experienced mold makers and plastics engineers in the business succeeded to reach 2x3,7° FWHM beam angle with the OSTAR SMT while guaranteeing a very uniform color mixing and high light output ratio of 90%. Several beams are available: 7.5°, 21°, 35°, 7.5°x37° as well as a zoomable system to offer further functionalities.

The specification of achieving a highly efficient narrow beam is a technical challenge requiring Gaggione to produce a collimator 45mm in diameter, demonstrating unique experience injecting thick polymer optics.

This 45 mm series in the LEDNLIGHT product-line, is the unique answer for lighting fixture designers using OSTAR SMT and looking for powerful multicolor light concentration. ■

## Carclo Technical Plastics in New Partnership with BJB

Carclo LED Optics, a division of Carclo Technical Plastics, is proud to announce that they are now supplying the BJB holder system. This has been specifically developed to accommodate Carclo's 20mm optic range. The system will offer Carclo's customers a greater degree of manufacturing flexibility when choosing how to secure their optic.



### Carclo offers BJB holders for their 20mm optic range

The BJB holder when used in conjunction with Carclo's optics provides the following advantages – whilst still harnessing the capability of Carclo's high performance optics:

- No soldering
- No adhesives

### Carclo / BJB now support the following LED's:

- Cree XLamp range
- Osram Dragon
- Seoul P4
- Philips Luxeon Rebel

The complete assembly process is as follows: The connectors (dependent on the LED) and the STARboard are both fixed with two screws. Electrical contact is by means of two push wire terminals. The optic holder is clipped onto the connector, and the optical system itself clips into this.

The advantage of the BJB system is non-soldered, providing a transferable quality between LED's. The complete manufacturing/assembly offers a flexible solution for certain applications. ■

## First Application of LUXeXcel's New "Printoptical Technology"

Ms. Karla Peijs, Queen's Commissioner for the province of Zeeland, printed the world's first LED lighting lens today in front of members of the press and distinguished guests. With this symbolic action, Ms. Peijs officially opened the new print platform at the LUXeXcel Technology Center in Goes.

The first series of LED lenses will be introduced in the 'Mera' lighting series produced by RZB Leuchten in Bamberg, Germany. The distinctive design of this series

of elegant LED reading lamps was recently awarded the 'Red Dot Design Award' and received an honorable mention.

LUXeXcel's recent success in making its 'Printoptical Technology' market-ready allows 'on-demand' manufacturing of products such as lenses and light distribution structures. The advent of this innovative production process immediately offers the LED lighting industry completely new growth opportunities.

"I am proud our team has succeeded in making this ground breaking technology available for the LED lighting market. 'Bottlenecks' that currently block the successful introduction of quality LED lighting to the market – in particular in lens development – can now easily be removed" said Richard van de Vrie, CEO of the LUXeXcel Group.

RZB CEO Reiner Jürgens is also very pleased with the development: "The production of optics is now more accessible than ever before. The removal of difficult design, development and manufacturing barriers associated with the production of the optics offers new possibilities for the lighting industry worldwide." We are both pleasantly surprised and proud that the first series of lenses has been produced for our 'Mera' series."

New energy-saving LED fixtures can now be introduced into the market faster, cheaper and with greater flexibility. In addition to significant time savings, this digital printing technology also opens up new product design possibilities for (O)LED lighting manufacturers. Graphic design is all that is needed to add logos, technical data or design elements into the same production process. Moreover, optical adjustments or quick modifications are easy to implement in production. ■

**LUXeXcel's printoptical technology can be integrated in thin objects and allows new design ideas, like lens in wood**

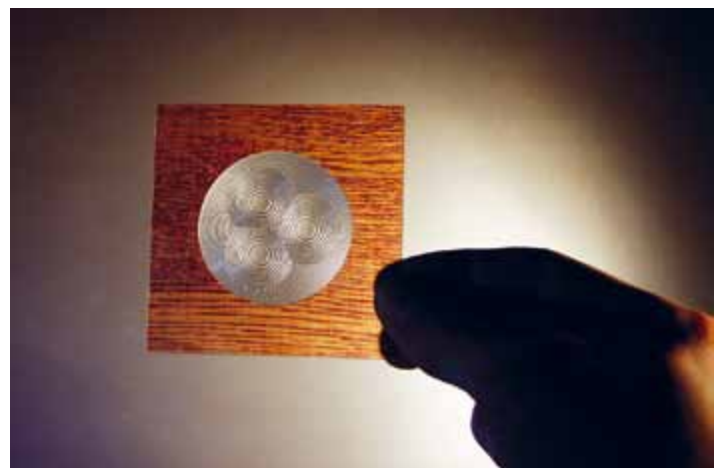

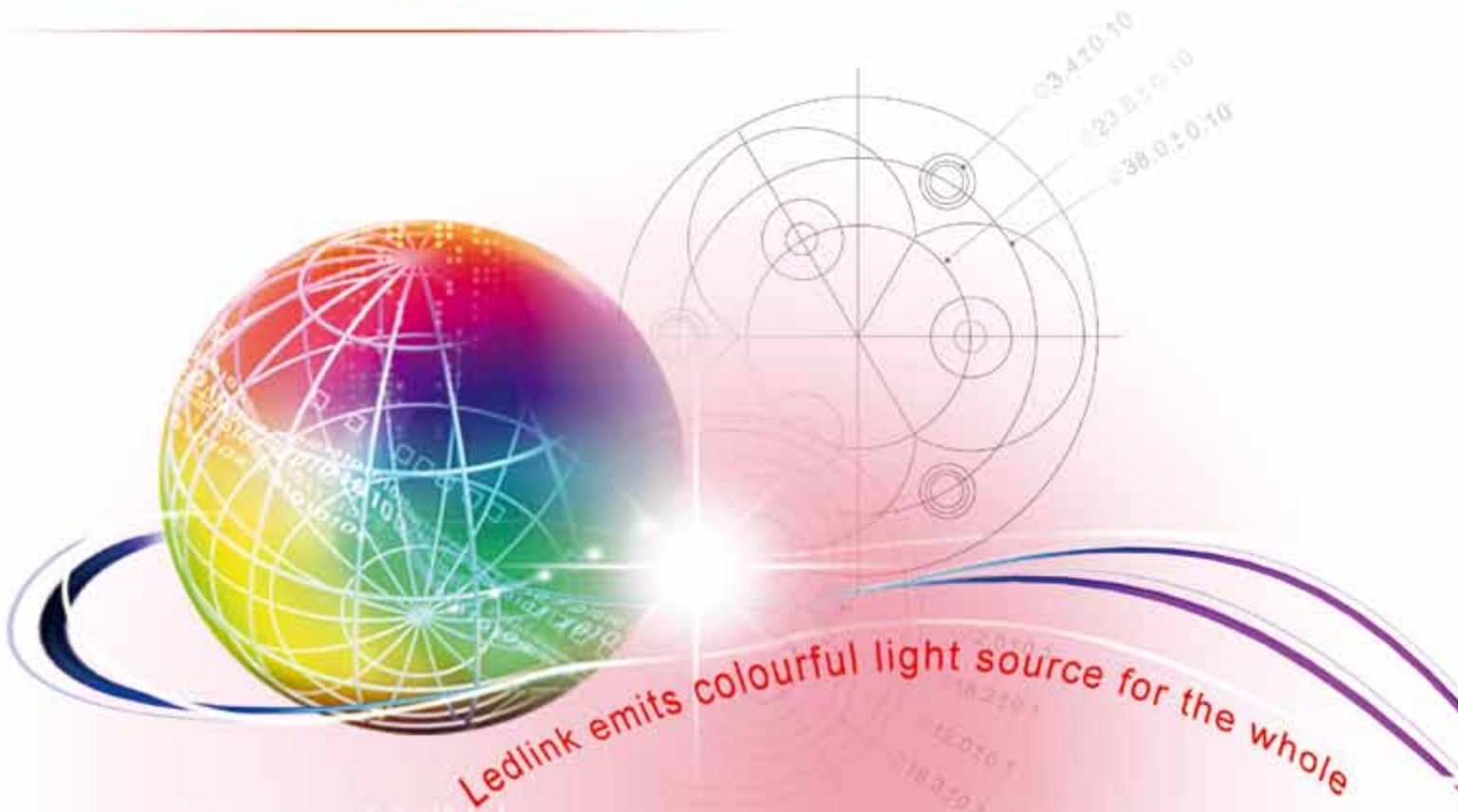

## Secondary Optical Lens design

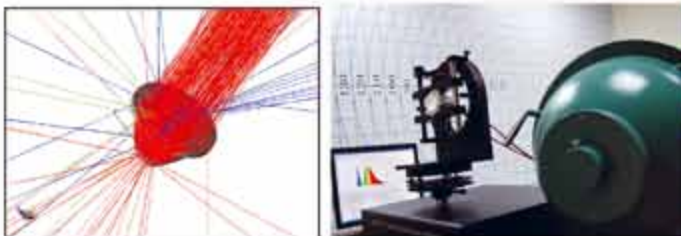

Ledlink is specialised in optical design, mechanical engineering, and thermal management, to provide optimised optical solutions. Delicating ourself to offer innovative solutions for our customers to create energy saving LED products is our co-operate mission, and to facilitate the development progress as well as the shift of solid state lighting industry. It is our co-operate goal to save more energy but provide brighter illumination and then shift our environment greener.



## Switch Lighting™ Introduces brightest LED Replacement Bulb

Switch Lighting, the only company with the closest alternative to incandescent-quality light, announced a brand new technology that produces the brightest warm light LED replacement bulb available. Using their “City of Light”™ technology, the bulb creates a self-cooling environment inside, allowing maximum brightness with fewer LEDs. With this technology, Switch Lighting is bringing to market the first true 75 watt equivalent warm white LED replacement bulb at an affordable price.

**Features:**

- Unique Design: Unique industrial design within the standard A-19 form factor.
- Bright Light Output: 1150 warm white lumens—a true 75 W replacement lamp.
- Uncompromising Functionality: Instant on, beautiful dimming operates perfectly in all orientations—up, down, and sideways—with no overheating or reduction in bulb lifetime.
- Lower Total Cost: Lasts up to 20 times longer than conventional lighting.
- Comfortable Light: More similar to the warmth and radial flux of an incandescent than any other LED replacement lamp.
- Outstanding Color Accuracy: A brilliant display of light with a CRI of 85.
- Highly Sustainable: Reduced energy consumption, performing brilliantly for thousands of hours, free of hazardous materials. All lamp components are completely reusable or recyclable, so no part ever goes into a landfill.

**Technical Data of Switch75**

Shape: A19 (Edison standard)  
 Fitting: E26 (Standard screw base)  
 Power: 16 W  
 Voltage: 120 VAC  
 Line frequency: 50-60 Hertz  
 Average lifetime: 20,000 hours  
 Color temperature: 2750 Kelvin  
 Light Output: 1150 Lumens  
 Color Accuracy: 85 CRI  
 Efficacy: 75 Lumens/Watt  
 Diameter: 2.73 inches  
 Height: 4.41 inches  
 Dimmable: Yes: 20-100%

“The LED lighting market is being redefined—people want sustainable, energy-efficient light sources without a compromise in incandescent light quality or design,” says Boris Lipkin, CEO of Switch Lighting. “Switch bulbs can be used just like a regular bulb - in all directions, in almost every light fixture and with most any dimmer,” added Mr. Lipkin.

Switch is designing their LED bulbs to meet Cradle to Cradle® principles—continuously and cost-effectively recovering all materials from the used light bulbs and safely biodegrading or recycling them. “Components won’t necessarily be repurposed into another light bulb, but could be siphoned into the broader industrial cycle,” says William McDonough, who developed the Cradle to Cradle protocol with German chemist Michael Braungart. “The unique design of Switch bulbs signals the company’s intention to offer brilliant lighting as a service for humanity,” added McDonough.

Because of the unique cooling system, Switch light bulbs can be used in any orientation with no compromise to their 20,000 hour life (10-15 years). Based on a 75 watt-equivalent bulb used in a home for 5 hours a day, Switch has

calculated energy savings of up to \$140.00 per bulb over its lifetime. The Switch LED bulbs use 85% less energy than incandescent bulbs and unlike compact fluorescents, they do not contain mercury. The purchase price payback in energy cost savings is realized in about one year.

“With our unique self-cooling technology, we make the brightest warm white LED light bulb available. We offer the most affordable, energy-efficient light bulb on the market that is nearly identical to the regular incandescent bulbs we’ve come to love.” says Brett Sharenow, Switch’s Chief Strategy Officer.

With increased energy costs and governmental calls for energy saving measures, people are increasingly looking for solutions, but don’t want to give up aesthetics, including the instant-on and warm light of their regular bulbs. Switch’s “City of Light” offers the same look, feel and quality of light as an incandescent. ■

## An Efficient Bulb for Chandeliers and Decorative Lighting: Magnolia LED Lamps

As the world announces its plans to phase out the 12.5 billion traditional incandescent bulbs used annually, how would we continue to light our artistic decorative lighting, especially crystal chandeliers? We would need a good energy efficient light source that can still deliver the brightness and shine.



Switch Lighting’s self-cooling technology offers the best and brightest warm incandescent-quality light



Some examples out of SFT’s Magnolia LED lamps range which can replace chandelier bulbs perfectly

SFT Holland Cooperative U.A will introduce its brand new Magnolia LED Lamps in the 3rd LED / OLED lighting Expo in Big Sight, Tokyo.

#### Product Benefits:

- No mercury, no UV light, no hazardous material, benefit for your health and environment friendly
- 85% energy saving, 5 W LED bulb substitutes 40 W incandescent bulb
- Long life, 25,000 hrs guarantees no maintenance for 10 years
- Similar size and shape as traditional bulbs, not necessary to change light fixtures
- Standard cap base fulfilling the requirements of your country
- Excellent stability of light color temperature by CREE® white LED technology
- Truer vision by high color rendering index
- Spark warm light by clear bulb, comfortable soft warm light by frosted bulb

#### Applications:

- Chandeliers, ceiling lights, wall scones, desk lamps, floor lamps, and decorative luminaries
- Hotel, restaurant, conference, meeting room, show room
- Retail lighting, museum lighting, hospitality lighting, accent lighting, architectural lighting

The Magnolia LED Lamp with a 300 degree beam angle, 300 lumen brightness at 2700 K, is the first energy efficient lamp to truly duplicate the look and feel of the incandescent bulb without the heat and high power usage. It uses only 5W to replace a traditional 40 W incandescent. These features make it the perfect energy efficient bulb for chandeliers and decorative lighting. Currently, there is no other LED lamp that is able to do this.

Gordon Tan, SFT's Chief Global Marketing Officer said "Now the world does not need to worry about how to light their beautiful chandeliers when they can no longer buy incandescent bulbs."

Magnolia LED Lamp is patented worldwide and now being launched in more than 20 countries globally. ■

## Low cost 3W and 6W LED-Driver with Constant Current Supply in Ultra Compact Design

RECOM announces the release of an extension to their range of isolated AC/DC-LED-Drivers with constant current-output in 3 to 6 Watt power supply

Advances in LED technology require low power of 1 W or 3 W for LED-illumination. The two new families meet the growing demand for low cost drivers below the previously available products with 12 W, 20 W, 30 W and 60 W power. With an input voltage range of 90 to 264 VAC the new drivers can be used universally on all networks worldwide.

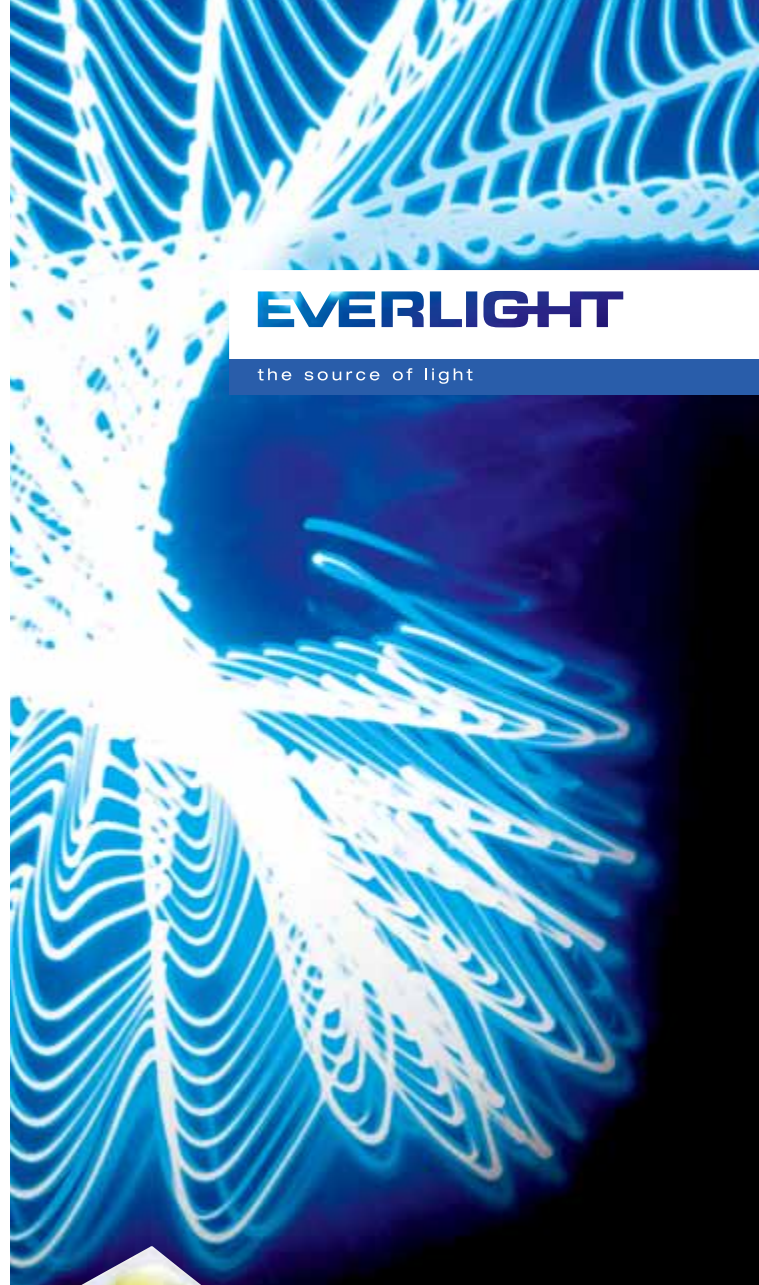

# EVERLIGHT

the source of light

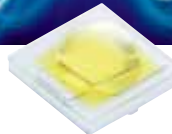

EVERLIGHT HIGH VOLTAGE LED.

## EFFICIENCY REDEFINED.

Discover a new standard in High Voltage LED: The new EVERLIGHT HiVo Series combines the efficiency of a DC LED with the simplicity of an AC LED. The ultra-compact design, flicker-free brightness and durability make the new EVERLIGHT HiVo 1W and HiVo 4W LED Series the first choice for your fixture solutions. Saving valuable resources was never a smarter option.

For more light and information enter [www.everlight.com](http://www.everlight.com)

LIGHTFAIR International ( 17~19 May 2011, Philadelphia )  
Booth No : 2645



The RACD03 can drive three 1W LEDs with 350 mA or single 3 W LED with 700mA constant current. The LED-Driver has flying leads. RACD03 is IP65 rated and can be used in damp areas such as sanitary facilities, exterior lights or cellar.

The RACD06 can drive six 1 W LEDs with 350 mA constant current or alternative two 3 W LEDs with 700 mA constant current. The LED-Driver has screw terminals and is ideal for applications that include low cost cabinet lighting, reading lamps and bathroom spotlights. Both drivers are designed for panel mounting and are supplied with mounting screws.

Although the converters are very compact with a low profile case that is 39 mm x 30 mm x 21 mm high for the RACD03 and 58 mm x 35 mm x 21 mm for the RACD06, they contain a fully featured input filter and meet EN61347, EN55015 and FCC18A without the need for any external components. The converters offer 3 kVAC isolation and are CE and EN safety certified. UL8750 certification is pending. The LED drivers are designed to give a long, trouble-free life. The "Design Lifetime" is rated at >20,000 hours, equivalent to 8 hours daily operating time up to 7 years. The warranty period is 3 years. ■

**RECOM's RACD series LED drivers are intended to drive three, respectively six 1 W LEDs in ultra-compact design**

#### Applications:

- The device can be used in all LED lighting applications that require:
  - very efficient, low THD
  - high PF
  - true universal input voltage
  - cost-effective power supply solution between 10 W and 300 W

#### Features and Benefits:

- Integrated PFC and flyback controller
- True universal mains supply operation: 70 V (AC) to 305 V (AC)
- High level of integration, resulting in a:
  - very low external component count
  - cost-effective design
- On-chip start-up current source
- Valley/zero voltage switching for minimum switching losses
- Frequency limitation to reduce switching losses
- PFC is switched off when a low load is detected at the flyback output
- Valley switching for minimum switching losses
- Frequency reduction with fixed minimum peak current at low power operation
- Safe restart mode for system fault conditions
- Continuous mode protection by means of demagnetization detection
- Under Voltage Protection (UVP) (fold back during overload)
- Accurate Over Voltage Protection (OVP) for both converters
- Open control loop protection for both converters
- IC over temperature protection
- Low and adjustable Over Current Protection (OCP)
- General purpose input for latched protection

## NXP's New Efficient SSL Solutions for Industrial, Warehouse and Street Light

NXP Semiconductors N.V. announced an addition to its broad GreenChip™ SSL family of products, the GreenChip SSL4101T controller IC, which offers new levels of professional-grade performance for Solid State LED lighting power supplies. The GreenChip SSL4101T enables LED lighting for medium to high power commercial and professional applications with industry-leading performance in Total Harmonic Distortion (THD) of less than 20 percent, a high Power Factor (PF) of .99, and high efficiency of 94 percent.

**Typical application circuit with NXP's GreenChip SSL4101T**

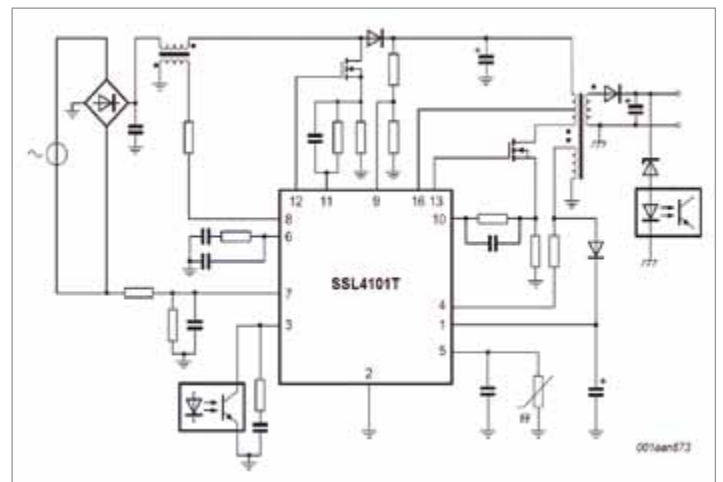



We bring quality to light.

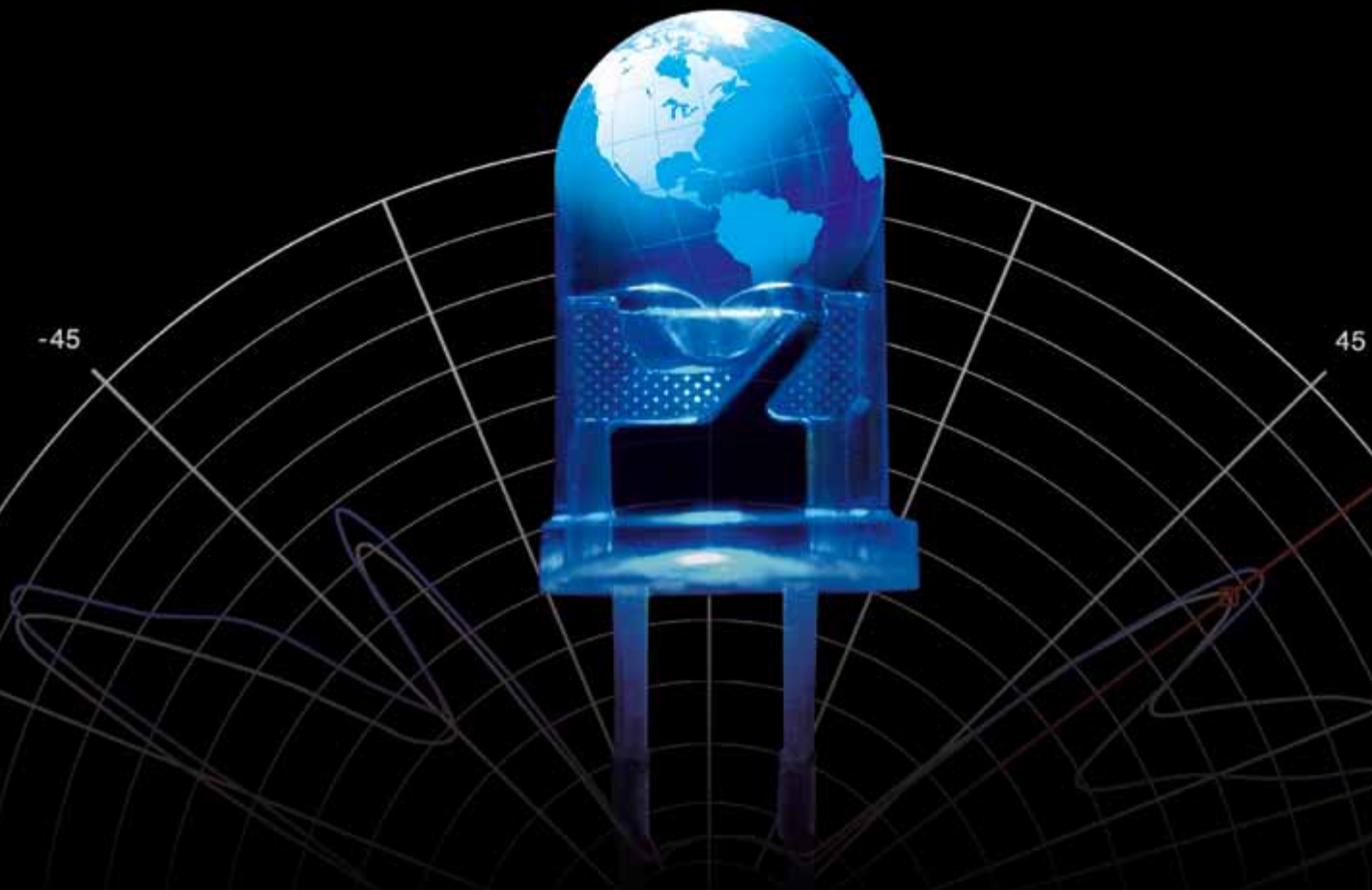

## LED test & measurement solutions from the world leader

Instrument Systems continues to set the benchmark in LED metrology. Whether testing individual LEDs (standard or high-power), LED modules, or OLEDs - the global LED industry relies on us to engineer superior measurement equipment for high-speed production testing and high-performance R&D and QC applications.



### Our instruments provide accurate and reliable results as per CIE recommendations and methods:

- Luminous flux [lm], luminous intensity [cd], and luminance [cd/m<sup>2</sup>]
- Chromaticity coordinates x,y,z and u'v'
- Color temperature and color rendering index
- Dominant wavelength and spectral data
- Spatial radiation pattern



“Today’s LED luminaire manufacturers are demanding increased power supply efficiency at lower costs in order to address new LED application segments,” said Jacques Le Berre, director of marketing and business development, lighting solutions, NXP Semiconductors. “GreenChip technology lies at the heart of NXP’s cost-effective, highly-efficient power and lighting ICs. The newly announced GreenChip SSL4101T offers a professional-grade solution with levels of efficiency of up to 94 percent, which is enabling LED adoption into a wider-range of professional lighting applications such as high bay and low bay lighting found in warehouses; and street lighting, where brightness and dependable illumination are essential.”

The GreenChip SSL4101T is based on NXP’s unique high voltage process and enables direct start-up from the rectified universal mains voltage in an effective, eco-friendly way. The multi-chip module contains both a flyback controller and a controller for Power Factor Correction, and provides high efficiency at all power levels. The new GreenChip SSL4101T is ideally suited for LED lighting applications that require a very efficient, low THD, high PF, true universal input voltage and cost-effective power supply solution ranging between 10 W and 300 W. ■

## Macroblock Introduces MBI6902 for T8 and E27 Applications

Macroblock introduces a new non-isolated, step-down and high efficiency AC / DC LED driver, MBI6902, especially for T8 and E27 lighting applications. The MBI6902 achieves superior efficiency in high brightness LED lighting applications. For example, the efficiency is over 90% when lighting up 6-LEDs @ VAC =110 V, 350 mA. The MBI6902 is able to drive external MOSFET current up to 3 A. In addition, the MBI6902 requires only a few external components. The high efficiency and compact solution of MBI6902 make it most applicable for T8, E27 and general illumination applications.

The MBI6902 accepts wide universal AC input from 80 VAC to 265 VAC and regulates the accuracy of preset output current within ±5% by switching the external MOSFET. Besides, the MBI6902 has multiple features to protect the controller from fault conditions, including under voltage lockout (UVLO), over voltage protection (OVP), over current protection (OCP), and LED open-circuit and short-circuit protection. Additionally, to ensure the system reliability, the MBI6902 is built with the thermal protection (TP) function. The MBI6902 is now available in MSOP-8L package. Samples and reference designs are now available. ■

## IR’s IRS2548D LED Control IC Increases Efficiency, Simplifies Design and Reduces Overall System Cost

International Rectifier, IR®, a world leader in power management technology, introduced the IRS2548D Switched Mode Power Supply (SMPS) control IC for energy efficient applications for high power Light Emitting Diode (LED) illumination including LED street lighting, stadium lighting and theatrical lighting.

The IRS2548D, which combines Power Factor Correction (PFC) and half-bridge driver in a single IC offers greater than 88% efficiency for a 40 V / 1.3 A HBLEDD load to deliver a higher efficiency solution compared to alternative flyback converter solutions at power levels above 60 W.

### Features:

- PFC, system control and half-bridge driver in one IC
- Critical-conduction mode boost-type PFC
- Programmable PFC over-current protection
- Half Bridge Driver
- Half Bridge Over Current Protection
- Variable Frequency Oscillator
- Fixed internal 1.6 us HO and LO dead time
- Internal bootstrap MOSFET
- Internal 15.6 V zener clamp diode on Vcc
- Micropower startup (250 μA)
- Latch immunity and ESD protection

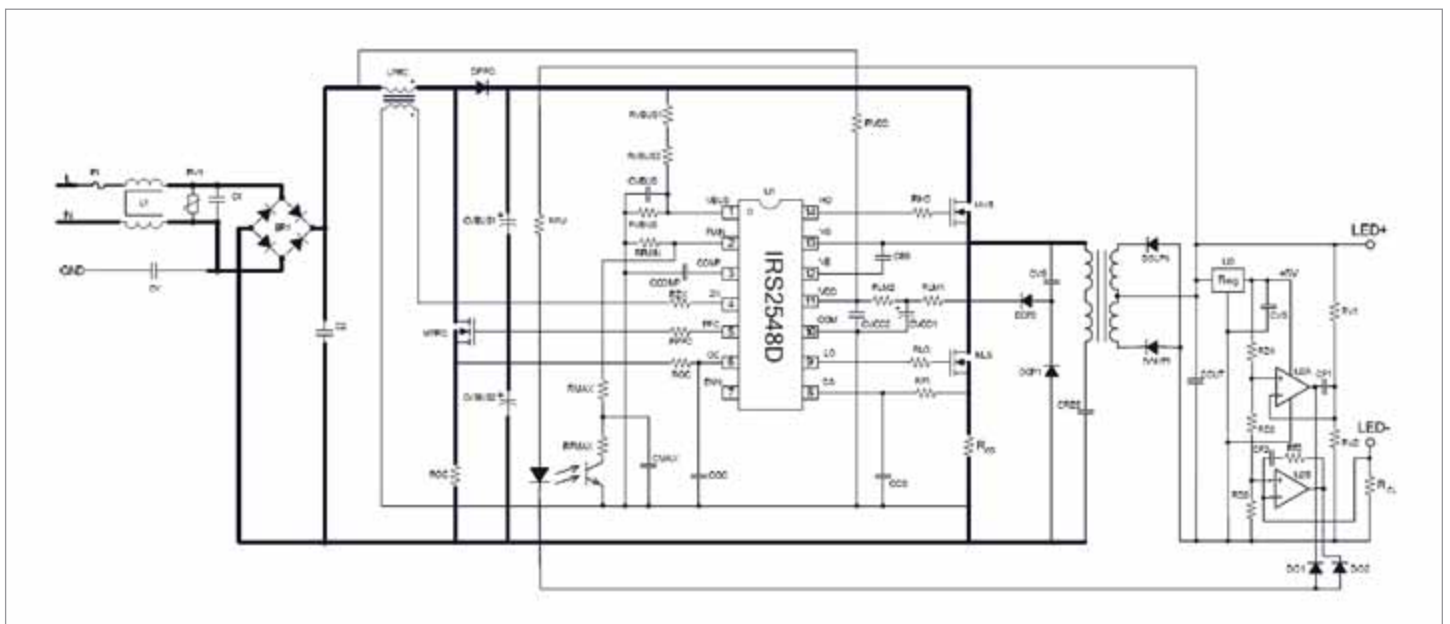

IR's new IRS2548D schematics for a typical application

**Typical Applications:**

- Isolated LED Drivers
- Power Supplies

“By incorporating both control stages into a single IC, the new IRS2548D provides an integrated solution for LED power supplies that simplifies design and helps reduce overall system cost, while providing significant energy savings,” said, Peter Green, LED Group Manager, IR’s Energy Saving Products Business Unit.

The new device achieves PWM dimming down to less than 2% light output and offers protection features that include programmable PFC and half-bridge over-current protection, latch immunity, and ESD protection. The IRS2548D also includes variable frequency oscillator, fixed internal 1.6 us deadtime, internal bootstrap MOSFET, internal 15.6 V zener clamp diode on Vcc, and micropower startup (250 µA). ■

## BIAS Low-Power Ruggedized AC-DC LED Drivers Meet Harsh Requirements for Outdoor Lighting

Bias Power’s new BPWXL Series of 4, 6 and 10 Watt constant current LED drivers offer 350mA constant current operation with 1% regulation over the entire input voltage range of 100-308 VAC, 50/60 Hz. Additionally, the drivers have unique cold-starting circuitry tested to -55°C, that is proven to kick-start LEDs even in frigid outdoor lighting fixture designs. The LED drivers are based on Bias’ patented\* circuit designs incorporating a custom ASIC controller.

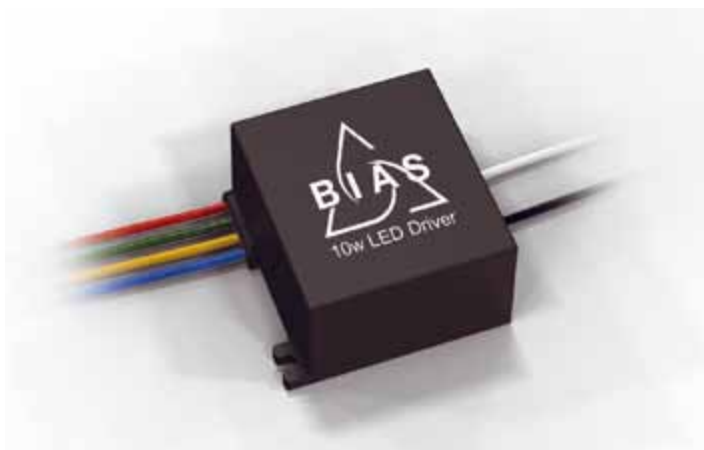

Bias ruggedized LED driver modules meet NEMA 6P / IP67 moisture and submersion and easily satisfy the strict requirements for outdoor architectural building and low-bay garage LED lighting. The LED drivers are rated for 3,000 VAC isolation and feature inherent over-current, short circuit (shorted string), overload and open circuit (string break) protection. All modules are specified for full-rated power over the temperature range of -40 to +85°C and operate at a nominal 80% efficiency, resulting in some of the highest lumens/watt end-to-end efficacy ratings for LED solutions in the market.

With a footprint of only 1.3 x 1.9 inches and less than 1 inch in height, the BPWXL6 provides up to 6 Watts of output power for LED string voltages up to 21 VDC. In the same package, the BPWXL4 provides up to 4 Watts of output power for LED string voltages up to 12 VDC. The BPXL10 is a 10 Watt driver module for LED strings rated up to 30VDC, and has a package size of 2.1 x 2.3 inches with a height of 1.25 inch. Standard connections are 11 inch, 18AWG ‘flying leads’ and dual mounting slots for ease of installation.

Bias Power LED Driver modules comply with UL/CSA and EN Product Safety Requirements (UL8750 Class 2) and meet conducted EMI emissions EN 55022, Class B and FCC Part 15, Class B. The modules have an MTBF rating of >500K operating hours. ■

**Typical application circuit using Diodes’ AL8806 buck LED driver**

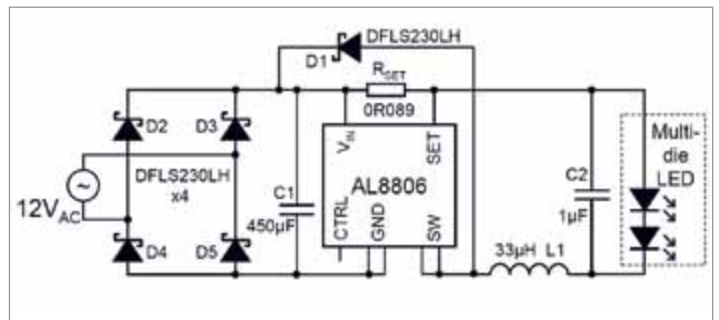

**Bias Power’s new BPWXL Series 10 Watt constant current LED driver**

## Diodes LED Driver for MR16, 12V and 24V LED Lamp Design

The AL8806 buck LED driver from Diodes Incorporated is capable of producing a constant current of up to 1.5 A from voltage sources of between 6 V and 30 V. Suiting MR16, 12 V and 24 V LED lamp design, the driver ensures a 5% average LED current accuracy for up to 9 high power LEDs over the wide operating voltage range, helping to significantly improve inter-lamp luminance matching.

**Applications:**

- High power MR16 lamps
- General illumination lamps
- Multi-die LED driver

**Features:**

- LED driving current up to 1.5 A
- Better than 5% accuracy
- High efficiency up to 98%
- Operating input voltage from 6 V to 30 V
- High switching frequency up to 1MHz
- PWM/DC input for dimming control
- Built-in output open-circuit protection
- SOT25 MSOP8-EP: Available in “Green” molding
- Compound (No Br, Sb) with lead free finish/ RoHS compliant

The high current handling of the AL8806 means it will also meet the needs of the latest multi die package LEDs, where current levels above 1 A are required. This simple, cost-effective driver is packaged in the small footprint low thermal impedance MSOP-8EP, supporting higher LED current drive at higher ambient operating temperatures. Device efficiency is high at up to 98%.

Maximum output current is simply set via a resistor and switching at a frequency of up to 1 MHz, the driver helps reduce the size of supporting external components, enabling

PCB size to be minimized. Lamp dimming is achieved by applying either a DC voltage or PWM signal that provides a wide range of brightness control that doesn't over drive the LED current. ■

## Mean Well Announces New Series of DC/DC Constant Current LED Drivers

MEAN WELL announced two kinds of encapsulated module type DC-DC buck converters for LED driving purposes - LDD-L and LDD-H series. With constant current mode output, LDD-L features with 9-36 VDC input and 2-32 VDC output while LDD-H possesses a wide range of 9-56 VDC input and 2-52 VDC output. Both series provide multiple output current options of 300 mA / 350 mA / 500 mA / 600 mA / 700 mA / 1 A (LDD-H only) for LED system designers to choose from.



**Mean Well's new LDD-L and LDD-H constant current DC/DC buck converters**

### Main Features:

- Constant current (C.C.) mode output
- Wide input / Output range
- 97% high efficiency
- Built-in PWM dimming function
- Cooling by free air convection
- Protections : Short circuit /Over temperature
- UL94-V0 level plastic case
- Approval : FCC / CE
- Dimension(LxWxH) :  
LDD-L - 22.6 x 9.9 x 8.4 mm  
LDD-H - 31.8 x 20.3 x 10.2 mm
- 2 years warranty

LDD series are designed to be mounted on the system PCB of lighting fixture. Their typical deployment is to connect to the output of CV (constant voltage) mode AC-DC LED power supply for providing a constant current to drive LEDs. Take a typical LED lighting fixture with multiple LED strings internally as an example, using LDD series not only can maintain good current balance for each LED string and hence ensure the long life of LEDs, but also can save the effort of sorting the Vf value of LEDs. Besides, because of the independent constant current nature, failure in any LED string driven by the LDD series won't affect the others, and each string can be connected for a different number of LEDs according to system design requirements.

With non-isolated Buck topology design, the LDD series possess up to 97% of extremely high efficiency and can operate between -40 to +85°C of ambient temperatures by only free air convection (up to 71°C for 600 mA ~ 1 A models). Built-in EMI filter, these LED drivers comply with EMI requirements per EN55015 lighting regulation without connecting any external EMI restraint components and are very convenient for PCB installations. The compact size also offers system designers great flexibility in PCB layout for power stage design. Other standard functions include PWM dimming, protections of short circuit and over temperature, wide range of input/output voltage. Besides, fully encapsulated packaging can help them withstand the influence of dust and moisture comes from all kinds of harsh environments. Suitable

applications include street lighting, landscape lighting, tunnel lighting, household lighting, and all kinds of indoor/outdoor LED lighting. ■

## Thermal Technology Provides Newly Developed K1 Sapphire Growers

Thermal Technology, a leading manufacturer of crystal growth equipment and high temperature furnace systems, recently finalized a sales agreement with Chongqing Silian Optoelectronics Science & Technology Co., Ltd. (Silian) for multiple Model K1 sapphire crystal growers.

"This new sales order signals continued industry acceptance of Thermal Technology's high-productivity industrial tool for sapphire crystal growth and will benefit both Silian and Thermal Technology going forward," says Matt Mede, Thermal Technology president and CEO. Shipments of Silian's multiple-unit order began in April, 2011.

Thermal Technology's newly designed Model K1 crystal grower is intended for LED substrate production. The tool's short cycle time makes it the most productive grower commercially available. To satisfy the high demand of the rapidly growing sapphire market, Thermal Technology is shipping systems weekly. ■



**Sapphire substrate (left) for LEDs, grown with Thermal Technology's K1 crystal grower**

# An Unique Service Plan that Exceed Your Expectations



- L1 Emitter
- ∨ L2 PCB
- ∨ L3 Optical
- ∨ L4 Heatsink
- ∨ L5 Circuit
- ∨ L6 Solution

- One** integrated trouble-shooting LED lighting service program.
- Offers **two**-way communications between a committed team and you throughout all the stages of product development.
- Combines **three** aspects of our total solution for LEDs including professional lighting design, manufacture and technical support.
- Solves **four** the most important issues which are identified as Thermal Management, Electrical Driving Conditions, Mechanical Refinement and Optical Optimization (T.E.M.O).

## Feature Products: The New Planar Light Source — EdiPower® II HV Series inside!

### LED Components



EdiPower® II HV  
Cool White



EdiPower® II HV  
Warm White

Power	Part Number	Color	I <sub>f</sub> (mA)	Flux (lm)	V <sub>f</sub> (V)	CRI
9W	EPSW-HFB4	○	250	970	38.7	68
	EPSX-HFB4	●	250	900	38.7	80
13W	EPSW-HFB6	○	350	1380	38.5	68
	EPSX-HFB6	●	350	1250	38.5	80

### An Example of Lighting Solutions

**Downlight (4" / 6" / 8")**

Power: 15W/ 25W/ 50W  
 LED luminous flux: 710~2850lm  
 Operating voltage: AC 100~240V  
 Color temperature: 1,000K/4,000K/6,000K  
 Color rendering index: 80/25/68  
 Beam angle: 60°/100°  
 Dimensions: 4" - R1.80 H70/  
 6" - R1.70 H90/ 8" - R2.30 H120 (mm)

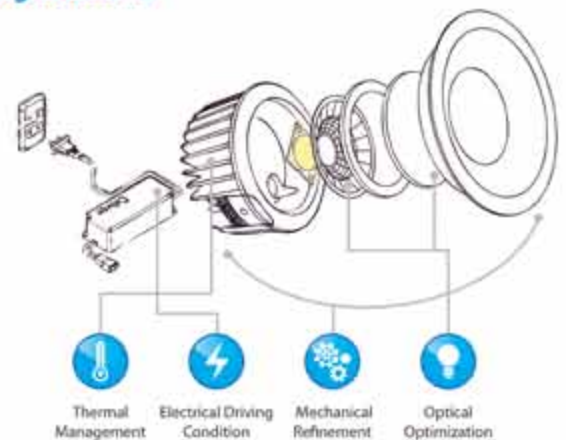

4F, No.800, Chung-Cheng Rd., Chung-Ho Dist., New Taipei City, Taiwan 23586

T+ 886 2 82276996 F+ 886 2 82276997 service@edison-opto.com.tw www.edison-opto.com.tw

## Essemtec Builds Production Line for LED Tubular Lamp

Until recently LED TL-tubes, a replacement for fluorescent lamps, had to be manufactured in a lavish modular design. In the future, using the new LED assembly line with a large-area printer from Essemtec, PCBs for such lamps can be manufactured fully automatically in a single, cost-efficient production run.

### Printing and assembling 180x50 cm PCBs:

A complete turnkey production line for LED tubular lamps consists of a large-area printer, three Cobra pick-and-place machines, a large-area reflow oven and modules for PCB handling. The line prints, assembles and solders PCBs with sizes up to 180x50 cm in one run. Its throughput is in the range of 54,000 LEDs per hour.

The new large-format printer, currently in concept phase, is designed for printing large, heavy boards. The innovative transport system provides excellent planarity during printing, even when processing pre-scored multi-boards and circuits made from composite materials. Printing direction is longitudinal over a width of 50 cm. Across the entire length of 180 cm, the printing results are consistent and of high quality.

In LED lamps, production speed is important as well as the precise alignment and placement of the LED components. Cobra type SMD pick-and-place machines are ideal for this task as they are fast, flexible and highly accurate. A Cobra pick-and-place can place LEDs of any size and shape and also can place other SMD components. Vacuum tool tips are specially coated to prevent any damage on the LED surface or lens. Three pick-and-place machines are producing simultaneously.



**The complete turnkey to manufacture LED TL-tubes to replace FL-tubes from one source**

### Same soldering conditions over the entire PCB length:

The light efficiency and life expectation of LED tubular lamps strongly depend on the equality of the LED soldering quality because the solder joint is an important element of the temperature management system. Therefore, each LED must be soldered precisely and with identical temperature profiles. Achieving such stability over the PCB length of 180 cm is not a simple task. Essemtec builds an advanced RO-VARIO reflow oven with special heating zones for such demanding soldering tasks. The oven features a homogeneous temperature profile across the transport direction and longitudinal direction, and the furnace precisely controls the soldering temperature. In this way the reflow oven ensures that all LEDs on a 180 x 50 cm PCB are soldered the same way.

### Complete turnkey from one source:

Essemtec, the Swiss manufacturer of production systems for electronics, delivers the complete production line including printer, pick-and-place, reflow oven and handling modules. The line can be completed with automatic dispensing systems and storage units. Essemtec also delivers software for production planning and optimization. ■

## Instrument Systems Launches Large Integrating Sphere for Testing SSL Light Sources

The ISP 2000 from Instrument Systems is the latest pioneering development launched by the leading manufacturer of light measurement systems worldwide. This integrating sphere has been specifically

designed with a diameter of 1.9 meters to facilitate precise measurement of total radiant power and luminous flux at lamps, luminaires and large LED modules.



### The ISP 2000 is the largest member of the well-established family of premium integrating spheres produced by Instrument Systems

The ISP2000 incorporates all the unique capabilities that brought success to its smaller peers of the well-established family of premium integrating spheres. These characteristics are particularly effective for testing solid-state lighting (SSL) products, conventional lamps and luminaires. The ISP 2000 is equipped with an auxiliary lamp to compensate for self-absorption, a temperature sensor to monitor the thermal conditions of the interior, and a detector port incorporating a fiber adapter to link the sphere with all spectroradiometers from Instrument Systems. The company offers a complete package of calibration accessories for the ISP 2000.

The ISP 2000 can be used to carry out measurements at 4π and 2π geometry. The maximum sample size is 600 mm x 300 mm x 300 mm in the center and the maximum sample diameter is 600 mm at the external measurement port. A lamp holder is available for mounting the test specimen inside the sphere. It accommodates optional adapters for all standard lamp sockets. A sample stage can be used instead of the lamp post for mounting non-standard sample sizes, for example complete luminaires and LED modules. This stage provides a footprint of 200 mm x 150 mm and a 16-pole terminal strip for connecting to a power supply or control circuit. A robust, rail-mounted sliding mechanism delivers light-tight closure for the ISP 2000 and permits the sphere to be opened easily for quick access. ■

## New Method for Manufacturing the Elusive Green LED with Higher Efficacy

Researchers at Rensselaer Polytechnic Institute have developed a new method for manufacturing green-colored LEDs with greatly enhanced light output.

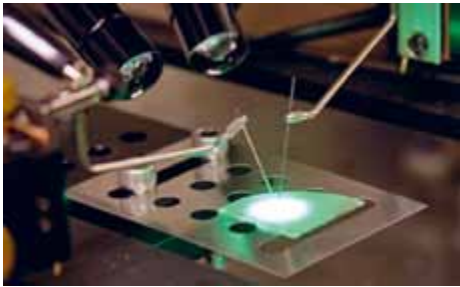

**Rensselaer researchers discover a new method for boosting the light output of green LEDs**

The research team, led by Christian Wetzel, professor of physics and the Wellfleet Constellation Professor of Future Chips at Rensselaer, etched a nanoscale pattern at the interface between the LED's sapphire base and the layer of gallium nitride (GaN) that gives the LED its green color. Overall, the new technique results in green LEDs with significant enhancements in light extraction, internal efficiency, and light output.

The discovery brings Wetzel one step closer to his goal of developing a high-performance, low-cost green LED.

"Green LEDs are proving much more challenging to create than academia and industry ever imagined," Wetzel said. "Every computer monitor and television produces its picture by using red, blue, and green. We already have powerful, inexpensive red and blue LEDs. Once we develop a similar green LED, it should lead to a new generation of high-performance, energy-efficient display and illumination devices. This new research finding is an important step in the right direction."

Sapphire is among the least expensive and widely used substrate materials for manufacturing LEDs, so Wetzel's discovery could hold important implications for the rapidly growing, fast-changing LED industry. He said this new method should also be able to increase the light output of red and blue LEDs.

Results of the study, titled "Defect-reduced green GaInN/GaN light-emitting diode on nanopatterned sapphire," were published in the journal *Applied Physics Letters*, and are featured in the *Virtual Journal of Nanoscale Science & Technology*, published by the American Institute of Physics and the American Physical Society. The paper may be viewed online at: <http://dx.doi.org/10.1063/1.3579255>

The research program is supported by the U.S. Department of Energy National Energy Technology Laboratory (NETL) Solid-State Lighting Contract of Directed Research, and the National Science Foundation (NSF) Smart Lighting Engineering Research Center (ERC), which is led by Rensselaer.

LED lighting only requires a fraction of the energy required by conventional light bulbs, and LEDs contain none of the toxic heavy metals used in the newer compact fluorescent light bulbs. In general, LEDs are very durable and long-lived.

The holy grail of solid-state lighting, however, is a true white LED, Wetzel said. The white LEDs commonly used in novelty lighting applications, such as key chains, auto headlights, and grocery freezers, are actually blue LEDs coated with yellow phosphorus – which adds a step to the manufacturing process and also results in a faux-white illumination with a noticeable bluish tint.

The key to true white LEDs, Wetzel said, is all about green. High-performance red LEDs and blue LEDs exist. Pairing them with a comparable green LED should allow devices to produce every color visible to the human eye – including true white, Wetzel said. Today's computer monitor and television produces its picture by using red, blue, and

green. This means developing a high-performance green LED could therefore likely lead to a new generation of high-performance, energy-efficient display devices.

The problem, however, is that green LEDs are much more difficult to create than anyone anticipated. Wetzel and his research team are investigating how to "close the green gap," and develop green LEDs that are as powerful as their red or blue counterparts. ■

## Theorists from UC Santa Barbara Claim that LED Efficiency Puzzle Is Solved

Researchers at the University of California, Santa Barbara, say they have figured out the cause of a problem that has made light-emitting diodes (LEDs) impractical for general lighting purposes. Their work will help engineers develop a new generation of high-performance, energy-efficient lighting that could replace incandescent and fluorescent bulbs.

"Identifying the root cause of the problem is an indispensable first step toward devising solutions," says Chris Van de Walle, a professor in the Materials Department at UC Santa Barbara who heads the research group that carried out the work.

Van de Walle and his colleagues are working to improve the performance of nitride-based LEDs, which are efficient, non-toxic and long-lasting light sources. They investigated a phenomenon referred to as "droop"—the drop in efficiency that occurs in these LEDs when they're operating at the high powers required

**Unlike scientists from the University of California, Santa Barbara, some other scientists are not convinced that Auger recombination is the cause for droop - other models are also proposed**

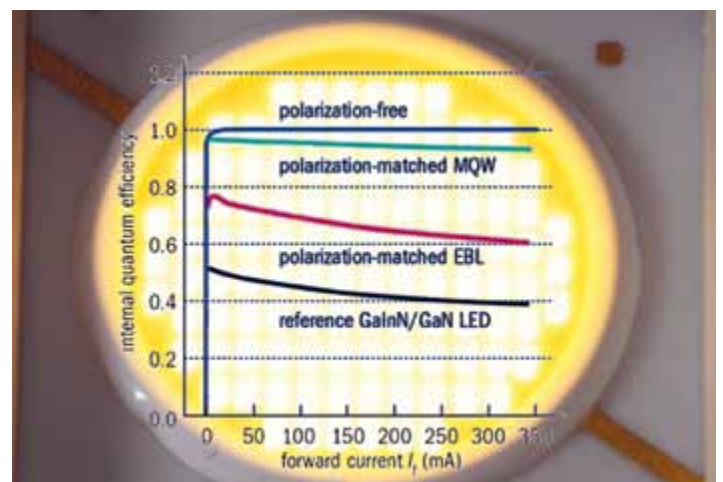

to illuminate a room. The cause of this decline has been the subject of considerable debate, but the UC Santa Barbara researchers say they've figured out the mechanism responsible for the effect by performing quantum-mechanical calculations.

LED droop, they conclude, can be attributed to Auger recombination, a process that occurs in semiconductors, in which three charge-carriers interact without giving off light. The researchers also discovered that indirect Auger effects, which involve a scattering mechanism, are significant—a finding that accounts for the discrepancy between the observed degree of droop and that predicted by other theoretical studies, which only accounted for direct Auger processes.

In nitride LEDs, “These indirect processes form the dominant contribution to the Auger recombination rate,” says Emmanouil Kioupakis, a postdoctoral researcher at UC Santa Barbara and lead author of a paper published online April 19 in *Applied Physics Letters*. The other authors are Van de Walle, Patrick Rinke, now with the Fritz Haber Institute in Germany, and Kris Delaney, a project scientist at UC Santa Barbara.

LED droop can't be eliminated because Auger effects are intrinsic, but it could be minimized, the researchers say, by using thicker quantum wells in LEDs or growing devices along non-polar or semi-polar growth directions in order to keep carrier density low.

“With Auger recombination now established as the culprit, we can focus on creative approaches to suppress or circumvent this loss mechanism,” Van de Walle says.

The work was supported by the Center for Energy Efficient Materials, funded by the U.S. Department of Energy, and by UC Santa Barbara's Solid State Lighting and Energy Center. Computational resources were provided by the U.S. DoE's National Energy Research Scientific Computing Center at Lawrence Berkeley National Laboratory, the California NanoSystems Institute's Computing Facility at UC Santa Barbara, and the National Science Foundation-funded TeraGrid.

#### Reference:

“Indirect Auger recombination as a cause of efficiency droop in nitride light-emitting diodes” - DOI: 10.1063/1.3570656 ■

## BRIDGELUX Demonstrates Dramatic Advancements in GaN-on-Silicon Technology for SSL

Bridgelux Inc., a leading developer and manufacturer of LED lighting technologies and solutions, announced that it has achieved a major breakthrough with the demonstration of 135 Lumens per Watt GaN-on-Silicon based LED technology. This represents the industry's first commercial grade performance for a Silicon-based LED.

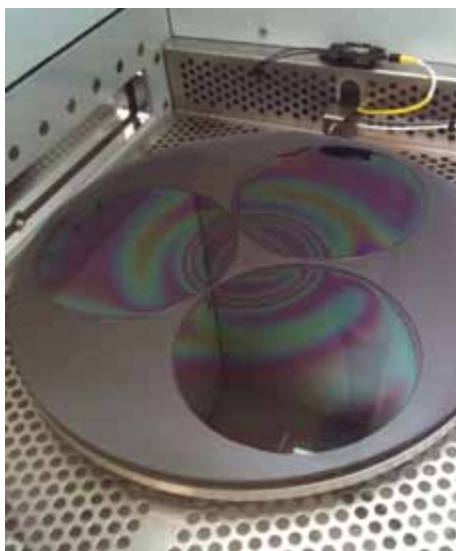

**Growing LEDs on low-cost large diameter silicon substrates needs special knowledge**

When grown at scale, most LED epitaxial wafers use sapphire or silicon carbide substrates as the starting material. But large diameter sapphire and silicon carbide substrates are costly, difficult to process,

**An optimized epitaxy process on 8-inch Si wafers will make LED manufacturing compatible with existing automated semiconductor lines**

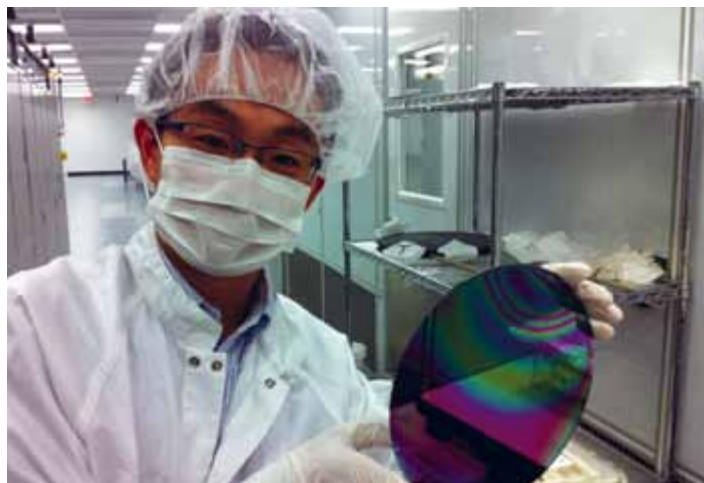

and not widely available. As a result, production costs have inhibited the widespread adoption of LED lighting in homes and commercial buildings. But growing GaN on larger, low-cost silicon wafers that are compatible with modern semiconductor manufacturing can deliver a 75% improvement in cost over current approaches.

The 135 Lumen per Watt performance was achieved at a CCT of 4730 K using a single 1.5mm power LED operated at 350 mA. These LEDs have extremely low operating voltages, requiring just 2.90 V at 350 mA and <3.25 V at 1 A. The low forward voltage and excellent thermal resistance of the devices make them ideally suited for high-performance, illumination-grade applications. Optimization of the epitaxy process on 8-inch Si wafers will make LED manufacturing compatible with existing automated semiconductor lines.

The move to a Silicon substrate will be a revolutionary step for the LED industry, and Bridgelux is well-positioned to take full advantage of the introduction of this technology. Over the past 5 years, Dr. Steve Lester, one of the industry's pioneers in LED Research and Development, has fostered a world-class team of Bridgelux materials scientists and chip design engineers dedicated to GaN-on-Silicon R&D. Concurrently, industry-wide research and development of GaN growth on Silicon has increased rapidly. And as a result, the GaN on Silicon performance levels reported by Bridgelux are comparable to state-of-the-art sapphire-based LEDs available 12-24 months ago. The company anticipates the delivery of its first commercially available GaN-on-Silicon products over the course of the next two to three years. ■



# E-tube™ Fluorescent LED Tube T8

Power In

You can touch (safe!)

180° Rotatable End Caps

Clear Cover

Frosted Cover

Wave Cover

User Friendly  
High Power Factor  
High Power Efficiency  
High Light Efficiency

T8 CAN BE USED IN A WIDE VARIETY OF LIGHTING APPLICATIONS:

parking lot residential mall warehouse signage bus office railway station

CE FC RoHS COMPLIANT warranty 3 years

SignComplex

SIGNCOMPLEX LTD

YiGu Industrial Park, Fuyuan Road, Qianhai Town, Baoan, Shenzhen  
Tel: +86 755 2730 8888 Fax: +86 755 2730 8881  
www.signcomplex.com info@signcomplex.com

## OSRAM Laboratory: Efficiency Record for Warm White

OSRAM Opto Semiconductors has set a new laboratory record of 142 lm/W for the efficiency of a warm white LED light source. With a correlated color temperature (CCT) of 2755 K the LED achieves a good color rendering index (CRI) of 81. Measurements were taken under standard conditions: room temperature and pulsed mode at an operating current density of 350 mA/mm<sup>2</sup>.

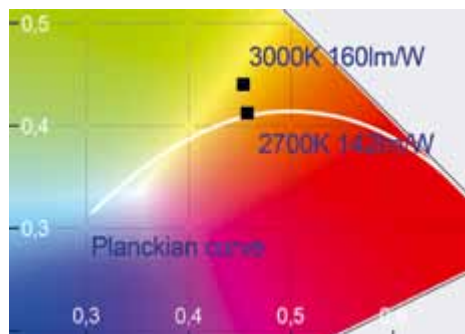

The laboratory setup for a warm white LED achieves a peak value of 142 lm/W directly on the Planckian curve at 2700 K; an optimized setup at 3000 K could achieve 160 lm/W

Bright warm white light with high efficiency is particularly important for lighting applications in the residential sector. The laboratory setup for a warm white LED shows the enormous potential of these energy-saving semiconductor light sources: The peak value of 142 lm/W measured under standard conditions is achieved at a color perception that very closely matches that of a classic incandescent lamp (color coordinates cx 0.46/ cy 0.41 on the Planckian curve).

“If we explore this technical approach further and allow deviations from the Planckian curve we should even now be able to achieve higher efficiency values of up to 160 lm/W for a correlated color temperature of 3000 K (cx 0.45 / cy 0.44)”, said Dr. Norwin von Malm, Predevelopment Manager at OSRAM Opto Semiconductors. “If we apply this approach to a 2 mm<sup>2</sup> chip we can improve efficiency by a further 10 to 15 percent for the same operating current. We would then expect 180 lm/W for a pure warm white LED and good color rendering.”

The increase in efficiency was made possible by combining new procedures in thin-film and UX:3 chip technologies and in conversion. Development engineers at OSRAM Opto Semiconductors have benefited here from

combined know-how in all aspects of the production process. These include epitaxial growth, thin-film chip architectures, conversion processes and package technologies. ■

## Advanced Materials Researchers "Brighten" Future of OLED Technology

Chlorine: an abundant and readily available halogen gas commonly associated with the sanitation of swimming pools and drinking water – could a one-atom thick sheet of this element revolutionize the next generation of flat-panel displays and lighting technology?

In the case of Organic Light-Emitting Diode (OLED) devices, it most certainly can. Primary researchers Michael G. Helander (PhD Candidate & Vanier Canada Graduate Scholar), Zhibin Wang (PhD Candidate), and led by Professor Zheng-Hong Lu, in the Department of Materials Science & Engineering at the University of Toronto, have found a simple method of using chlorine to drastically reduce traditional OLED device

complexity and dramatically improve its efficiency all at the same time. By engineering a one-atom thick sheet of chlorine onto the surface of an existing industry-standard electrode material (indium tin oxide, ITO) found in today's flat-panel displays, these researchers have created a medium that allows for efficient electrical transport while eliminating the need for several costly layers found in traditional OLED devices.

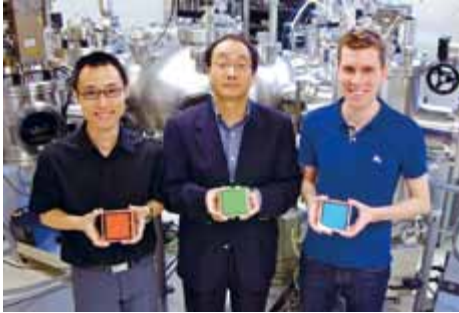

The research team that developed the "CI-OLED" (left to right): Zhibin Wang (PhD Candidate), Professor Zheng-Hong Lu, and Michael Helander (PhD Candidate + Vanier Canada Graduate Scholar) hold their CI-ITO enabled OLED devices



Red, green and blue CI-ITO-OLEDs from the University of Toronto Material Science and Engineering Institute

It turns out that it's remarkably easy to engineer this one-atom thick layer of chlorine onto the surface of ITO," says Helander. "We developed a UV light assisted process to achieve chlorination, which negates the need for chlorine gas, making the entire procedure safe and reliable."

The team tested their green-emitting "CI-OLED" against a conventional OLED and found that the efficiency was more than doubled at very high brightness. "OLEDs are known for their high-efficiency," describes Helander. "However, the challenge in conventional OLEDs is that as you increase the brightness, the efficiency drops off rapidly." Using their chlorinated ITO, this team of advanced materials researchers found that they were able to prevent this drop off and achieve a record efficiency of 50% at 10,000 cd/m<sup>2</sup> (a standard florescent light has a brightness of approximately 8,000 cd/m<sup>2</sup>), which is at least two times more efficient than the conventional OLED.

"Our CI-ITO eliminates the need for several stacked layers found in traditional OLEDs, reducing the number of manufacturing steps and equipment, which ultimately cuts down on the costs associated with setting up a production line," says Professor Zheng-Hong Lu. "This effectively lowers barriers for mass production and thereby accelerates the adoption of OLED devices into mainstream flat-panel displays and other lighting technologies."

The results of this work titled "[Chlorinated Indium Tin Oxide Electrodes with High Work Function for Organic Device Compatibility](#)" were published online in the journal, *Science*, on April 14, 2011 (Science DOI: 10.1126/science.1202992). ■

## Correction: Author's Reference in Index of LpR24

LED professional apologizes for accidentally having used a wrong author's reference for the article "Advanced Lighting Technology Needs an Advanced Color Rendition Metric" in the Index of LED professional Review 24 - March/April issue.

### Please take note of the corrected reference:

Advanced Lighting Technology Needs an Advanced Color Rendition Metric by Artūras Žukauskas and Rimantas Vaicekauskas, Vilnius University; Michael Shur, Rensselaer Polytechnic Institute ■



## New Designed LED Tubes with TÜV Certification from Willighting

In order to satisfy the safety requirements of LED tube installation from EU, Willighting adopts new TUV standards and schemes for producing.

New designed LED tubes are safer and easier to replace the traditional tubes. Keep your ballast, then simply remove the starter and replace with new one from Willighting.

There is no change for the existing circuit.

For more detailed technical and sales information, please contact Willighting sales team.



**NEW!**

# Does your driver match the life span of your LEDs?

**RECOM's new 3, 6, 12, 20 and 60W AC Input LED Drivers do!**

- ✓ Constant current outputs of 0.35/0.5/0.7/1.05 & up to 4.2A
- ✓ Universal AC input voltage (90 to 264VAC)
- ✓ Power factor corrected (RACD12/20/60)
- ✓ 3kVAC isolation
- ✓ Fused input and protected output
- ✓ Input and output screw terminals
- ✓ Additional 5.5mm socket output connection
- ✓ Meets UL8750, UL1310, EN61347 & EN55015
- ✓ Design lifetime up to 70.000 hrs (RACD12/20/60)
- ✓ 5-year warranty (RACD12/20/60)



Introducing the new RACD series - low power AC input LED drivers. RECOM is now offering a low cost solution for low power Solid State Lighting. The family includes 3W, 6W, 12W, 20W and 60W modules in varying packages capable of driving up to 19 high brightness LEDs or high power arrays.

## Building an LED lamp has never been easier!

RECOM LED Drivers are compatible with most LEDs in the industry. We work closely with the leading LED manufacturers to bring to the market the right drivers for the right LEDs.

## Typical Applications

- Indoor/Outdoor lighting
- Cabinet lighting
- Recessed lighting
- Fluorescent tube replacement
- LED array modules
- Panel replacement
- Decorative lighting
- Desk lamps
- Freezer lighting
- Landscape lighting
- Theatrical lighting
- Street Lighting



**RECOM Electronic GmbH**  
Otto-Hahn-Str. 60  
D-63303 Dreieich  
Tel. +49 6103 30007-0  
info@recom-electronic.com  
www.recom-electronic.com



# LED Investor Forum 2011 – Santa Clara

Alan R. Miles reports exclusively for LED professional about the expectations of venture capitalists, what manufacturers are planning for the near future, market trends and sales forecasts which were presented at the one-day Investor Forum in Santa Clara.

At the recent Strategies in Light meeting in Santa Clara, California, Pennwell Publishing hosted a one-day Investor Forum that indicated a global interest in the financial support for light emitting diode (LED) lighting companies. Several hundred attendees were present at this event, including many venture capital representatives seeking suitable investments plus some companies with promising LED lighting products that were seeking additional investment for expansion purposes. Vrinda Bhandarkar, from Strategies Unlimited, opened the proceedings with an overview of the LED lighting markets where LED luminaire development is rapidly changing the industry structure. She noted that LED lighting companies raised about \$145 million of new capital in the USA in 2010 and halfway through February 2011 an additional \$22 million in investments had been placed. The maturation of the LED use in lighting is creating a convergence of light sources, ballasts and fixtures in a market where LED luminaires and replacement lamps are developing into new market segments. Fortunately for LED lighting, the investment community is actively looking to support new ventures in these rapidly growing LED market segments.

In 2010, LED performance was no longer a limiting factor for solid-state lighting, since the best commercial cool whites had achieved 160 lm/W (a 10x improvement over the LED performance in 2000) and warm whites, with 109 lm/W efficiencies, were over 3x better. At these high lumen levels, the disruptive LED can also be considered as a serious contender for fluorescent lamp replacement, especially with a recent LED tube replacement offering for T-5 fluorescent lamps, namely the D-LUX® from THE DIGITAL LIGHTTM Company. This market opportunity can only improve as LED efficiencies improve and as the dollar per kilolumen cost of LEDs continues to fall. In the same 10 year period, the average lumen output from a one watt cool white LED package has increased more than 20 fold and the \$/kilolumen cost has decreased by more than 10 x. Today, the significant LED lighting market segments include commercial and industrial, architectural, retail display, flashlights, safety, outdoor area, and solar off-grid. However, despite continuing reductions in LED costs and improving efficiencies, the cost of the LED can still be a limiting factor for some general lighting applications. Vrinda reported the LED luminaire lighting market to be almost \$5 billion in 2010. Both the replacement lamp and consumer portable markets were 20% of this value with the architectural and commercial segments, each being about 15%. Much of this growth in LED use has been cost of ownership based and supported by incandescent

replacements, some fluorescent replacements and niche markets. In the near future, the rapid adoption of LEDs for street lighting will produce another significant LED market growth segment. Cannacord Genuity, an investment company, is also a proponent for LEDs and their in-depth research indicates that the adoption of LED lighting will achieve about a 46% market penetration by 2020, a value chosen in the centre of the estimated low to high range of 30-60%. This selected level of market penetration could remove a cumulative 8.4 billion tonnes of CO<sub>2</sub> from the air, an amount equal to the emissions from all the cars in the world!

Entertainment lighting is another example of LED efficiency and although it is not a large market segment, it has been an industry leader and a rapid innovator of LED technology, because coloured LEDs use less power than other sources and require no filter gels, no moving parts, yet they can provide easily controllable high flux lighting with rapid switching attributes. As an example, at the recent 2011 US Superbowl, all the lighting (except the spot lighting on the lead entertainers) was LED based and allowed low power rapidly switched illumination for the whole cast of performers.

In the next 5-year period, Vrinda forecast the total LED markets to increase by 4x to \$20 billion, the LED luminaire market to more than double and the replacement LED lamp market to grow by a factor of 11 or more to exceed \$11 billion by 2015. Much of this

LED market growth will be supported by products that offset rising energy costs, reduce greenhouse emissions, benefit from the compatibility of use of LEDs with intelligent lighting controls, meet national security needs, support incentives such as incandescent phase outs and mercury reduction and for some countries, relieve national pressures to conserve foreign exchange resources for fuel used for lighting. This growth can now be supported by a rapid proliferation of base-compatible, 90 lumen per watt or better, LED lamps to replace existing A-19, R-20, R-30, R-38 and MR-16 bulbs. However, even with this expected LED market growth, challenges still exist for LED luminaires, including bad press from poor quality and no warranty early LED luminaires, LED product education, not enough standards, improved warm-white efficiency and potential competition from other light sources such as plasmas.

Recently, support has enabled a wide range of diverse LED-lighting support companies to be funded. An example would be Inlustra Technologies, which is a 2005 spin out from UCSB, focused on the development of Hydride Vapour Phase Epitaxy processes for the production of low defect density, large area, low cost, semipolar and nonpolar bulk gallium nitride device substrates. These a- and m-plane gallium nitride substrates will enable the production of higher brightness green LEDs, long a weakness for the production of more efficient LED green and RGB sources of white, plus they will also enable the efficient production of R, G & B laser chips, especially green laser diodes. Ben Haskell, Inlustra's CEO, believes that the use of these substrates will lead to a 10 fold reduction in the cost of LED lumens combined with a much improved and very small efficiency droop that enables high

brightness LED green emission that does not vary with the applied current. Ben reported that standard GaN LEDs are often limited to the emission of 60-100 lumens/mm<sup>2</sup>, whereas GaN devices grown on semi- and non-polar substrates have the potential for up to 3000 lm/mm<sup>2</sup> light outputs that will allow the manufacture of either more intense LED sources or smaller LED chips for the same light output, thus lowering LED materials costs. Assuming that the next investment round for Inlustra is successful, these new substrates could further advance the acceptance of LEDs into the lighting markets based on higher performance and lower chip costs. Ben forecast that Inlustra will bring 4-inch gallium nitride substrates to the market in 2013 and that the market for these a- and m-plane wafers will grow from about 50,000 substrates in 2011 to 450,000 in 2015.

BritePoint, Inc., is also a venture startup founded to supply specialized LED lighting in the form of 'extreme high brightness' luminaires that can replace the more than 250 million metal halide fixtures presently installed in North America. They are reported to form a potential \$100 billion plus market that requires replacement every 12-18 months. BritePoint luminaires are focused on high wattage lighting applications served by LED arrays that will replace halide sources, all with outputs higher than 10,000 lumens. The BritePoint LED replacements will have 85% higher lighting efficiencies and two to three times longer lifetimes. Thus, the company's E39-base lamps will provide 70% savings and longer lifetimes over the metal halide competition. Tom Griffin, the BritePoint CEO, is seeking a \$10 million additional investment for a facilities expansion that will support 'explosive growth' for the company to \$100 million in three years and to \$700 million in five.



## LEDs – The Future of Street Lighting

Thanks to the LED solutions provided by Vossloh-Schwabe, municipal, district and rural authorities can not only save energy and reduce costs over the long term, but can also make a key contribution to reducing their carbon footprint.

Municipal and district authorities stand to make long-term gains due to the advantages offered by LEDs – and particularly when it comes to street lighting.

Benefits include:

- low maintenance costs due to long LED service life
- low impact on resources due to low energy consumption and constantly optimised lighting levels
- pleasant colour temperatures that contribute to making cityscapes more attractive

Vossloh-Schwabe's system solutions are the perfect choice for outdoor lighting purposes. Powerful LED modules fitted with efficient optics attachments combine with VS control gear – also suitable for power reduction purposes – to form the luminaire concept of the future.

Vossloh-Schwabe can also assist you in developing efficient LED luminaire designs. By speaking to one of our experts at an early stage of the development project, you can secure the support of Vossloh-Schwabe from the word go.



**Vossloh-Schwabe Deutschland GmbH**

Phone +49/23 51/10 10 · [www.vossloh-schwabe.com](http://www.vossloh-schwabe.com)

**Figure 1:**  
Replacement lamps of different form factors, from A19 over PAR to MR16m were also a hot topic at the Investor Forum (Img.: Courtesy of Lighting Science Group)



A further advance in LED lighting technology was announced by Ventiva Inc, a private, Foundation Capital backed, company located in Northern California. This small Company is a pioneer in the solid state cooling of LED replacement lamps, using their 'no-metal' Ventiva Solid-State-Fan™ (VSSF) technology. According to Carl Schlachte, Ventiva's CEO, the Company is now sampling worldwide and has secured its first two customers. It will start shipping to the US and Asian markets in early 2012, with their target product being the 120V A-19 bulb type. The LED bulb has the standard shape, but there is a plastic shell on the Edison base and superimposed on this (and under the LEDs) is the VSSF that is claimed to provide a constant 30°C-delta over the ambient temperature. The top part of the globe contains the 1600 lumen Bridgelux LED package. In a sample comparison, Carl indicated that a Toshiba, 7.5 W LED A-19 provided 560 lumens at a CRI of 65 (74 lm/W) whereas a Ventiva-enabled A-19 used 31 watts, but had a directional output of 1600 lm at a CRI of 80 and a 52 lm/W efficacy. This is a better output than the 100 W incandescent bulb and would be much more suitable for residential buyers, with the inference being that the VSSF technology provides a much smaller and lower cost alternative to the use of bulky aluminium heat exchangers.

This Investor Forum also heralded the coming of age of gallium on silicon technology (GaN/Si) with two companies providing data on their commercial GaN/Si LED chips already on the market. One is the China-based Lattice Power Corporation, a venture funded company, with the CEO, Sonny Wu, also being a strong proponent of the GaN/Si technology. At the meeting, Sonny also claimed Lattice to be the fastest growing LED Company in China and described their one watt LED GaN/Si chips that had been under development since 2008 and that have been sold commercially since mid-2010. Lattice uses both AIXTRON and Veeco MOCVD equipment for GaN/Si epitaxy in a 120,000 square foot production facility. The reported performance of these LED chips was 110 lumens at 5000 K, based on forward voltages in the 3.1-3.2 V range, operating currents of 350 mA and light efficiencies in excess of 50% EQE. Lattice has strong support from the local government and is planning to add about 45 more MOCVD reactors in 2011 plus a scale up to 150mm wafers. The company also produces 120 V Edison base 7 W-lamps for the residential market that produce 700 lumens of cool or 480 lumens of warm white light. These bulbs were reported to have an estimated 40,000 hour useful life and offer CRIs of 67 for cool and 80 for warm white output at respective

efficiencies of 92 lm/W and 67 lm/W, with a proposed high volume price of \$8/unit later in 2011.

The second GaN/Si Company that is shipping both high brightness LEDs and power electronic chips is Azzurro Semiconductors AG a pioneer of this technology and a 7-year old venture-backed spin out from Magdeburg University in Germany. It received its last round of funding of €14.5 million in late 2010 for new facilities and to add more reactors. Azzurro reports that it has solved the hetero-substrate epitaxy growth problems, including crack-free GaN (up to 9 microns thick) on 6-inch silicon, wafer-bows of less than 20 microns over 150 mm and dislocation densities comparable to the widely used GaN on sapphire. The Company claims to have good IP protection and presently manufactures their GaN/Si chips on 6-inch silicon wafers. Azzurro plans to have an expanded MOCVD reactor capacity on line by mid-2011 and a scale up to 8-inch substrates by the end of the year. Additionally, the Company offers GaN/Si GaN-epitaxy wafers and a line of LEDs that can boast of a high breakdown voltages (750 V), suitable for being driven directly from mains voltages.

This Strategies in Light Session was a very good Investor Forum and provided an excellent outlook for LED products and support in the general lighting market, a picture that continues to improve! ■



**carclo**  
technical plastics

Dynamic in approach,  
Precision in execution

Catch us at Lightfair 2011  
Stand number 3456

General Lighting

Street & Area Lighting, Interior Linear Lighting

Automobile



TIR Optics & Reflectors



Hybrid Optical Systems & Modules



Continuous Extruded Optics



Custom Design & Manufacturing

**Opticselect**

www.carclo-optics.com  
sales@carclo-plc.com

Serving the solid-state lighting industry through a unique network of plants, warehousing facilities and distributors located in Europe, the Americas and in Asia

600 Depot Street  
Latrobe, PA 15650  
USA  
Tel: +1724 539 6982

103 Buckingham Ave  
Slough, Berkshire  
England, UK  
Tel: +44(0)1753 575 011

27A, (2) KIADB Industrial Area  
Dodabalapur, Bangalore - 561 203  
Karnataka - India  
Tel: +91 80-27630244

21 Lian Xi Lu  
Huang Du Zhen  
Jia Din District  
Shanghai 201804, China

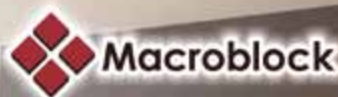

**MBI6902**

**Step-down, High Efficiency, Non-isolated AC/DC LED Controller**

- Accept universal AC input from 80VAC to 265VAC
- Hysteretic PFM improves efficiency at light loading  
Efficiency = 90% @ VAC = 110V, 350mA, 6-LEDs
- Setting current accuracy within  $\pm 5\%$
- To drive external MOSFET current up to few Amperes
- Full protection: Thermal/UVLO/OVP/LED Open-/Short- Circuit
- Available package: MSOP-8L

**Applications:**

- T-8 CFL Replacement LED Solution
- E27
- PAR30
- Power Supply for Light Panel
- Other LED lighting

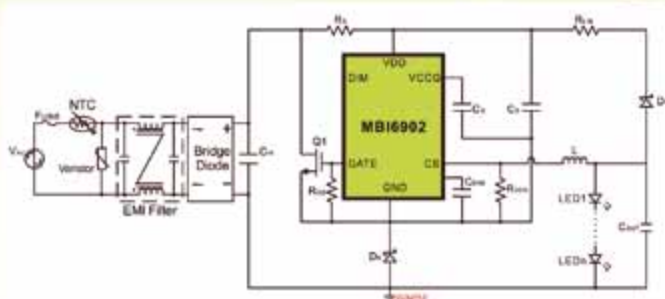

16th Guangzhou International Lighting Exhibition

Duration: June 09-12, 2011  
Venue: Chinese Export Commodities Fair Pazhou Complex  
Booth No.: Hall 11.2 / No. F22

Tel: +886-3-579-0068 • Fax: +886-3-579-8934  
Website: www.mblock.com.tw • Email: marketing@mblock.com.tw

# LED Street Lighting - About Standards, Challenges and Misconceptions

Siegfried Luger and Arno Grabher-Meyer from LED professional discusses several street lighting issues with Prof. Dr.-Ing. habil. Tran Quoc Khanh from the Institute for Microtechnology and Electromechanical Systems at the TU Darmstadt, getting insights into European street lighting standards, the human light perception, some misinterpretations of lighting facts and the future perspectives of LED street lighting.

**LED professional:** First of all, thank you very much for granting this interview with us. We'd like to begin with the subject of standardization. What are the current standards?

**Prof. Khanh:** The EN 13201 has been valid in Europe since April 2004. This is partly based on the DIN Norm, 5044 that was developed about 30 years ago and which was valid until about 2005. About 80-90% of the guidelines from DIN 5044 were carried over into the EN 13201.

**LED professional:** Does the EN 13201 describe the different types of streets and their requirements for illumination?

**Prof. Khanh:** First of all, the traffic situation has to be determined. In order to be able to classify a street one must first define how much traffic is on it and what the maximum speed limit is. In addition, it also has to be defined if, for example, the street is a mix of bicycle path, walkway and roadway.

**LED professional:** Light from different light sources has various effects on the ability to see. Does the EN 13201 cover these aspects or does it only address the general guidelines?

**Prof. Khanh:** In principle, this norm divides the streets in Europe into two basic types. The first type is the

so-called service and collecting road where the illuminance is the luminous quantity, for example S4 class with 5 lx, and the other is the so-called public highway where the luminance is relevant. The higher the illuminance and luminance is, the lower the number of accidents and crimes.

**LED professional:** Are similar standards to the EN 13201 valid on an international level?

**Prof. Khanh:** In the USA and Japan, for example, completely different norms apply but the scale of permitted values are similar.

**LED professional:** How does the way people see during the day and at night influence the development of street lighting?

**Prof. Khanh:** That is probably the biggest problem at the moment. All norms, like for example, the EN 13201, use photopic photometric units like lux and/or cd/m<sup>2</sup> which are based on day vision. This only begins at a luminance of 5-10 cd/m<sup>2</sup>.

Generally, the research results can be summarized like this: For small streets, like for example, service roads where 3-5 lux (about 0.20-0.50 cd/m<sup>2</sup>), is necessary, the advantage of white emission, like, for example, from an LED or a mercury vapor lamp, is very

high. In these cases you can count on about a 30-40% visibility gain when using LED lighting. Big streets with over 1-2 cd/m<sup>2</sup> have smaller and smaller gains and the values for twilight vision come close to the values for day vision. The norm values for public highways can therefore be seen as correct.

**LED professional:** Does this mean a possible 30-40% energy savings for service roads?

**Prof. Khanh:** Most people think that you can save energy by dimming the light by 30-40%. This is not really correct because it depends on the individual visual task. Let's assume, for example, that we want to be able to recognize a person's face so that in the case of a crime, a description of the perpetrator can be given. For this visual task the visual performance "visual acuity" is relevant, which means that the white LED light doesn't have any advantages. If, however, we are talking about making a street look bright, a person perceives LED light as brighter and you can dim the light by 30-40%. The white light is advantageous because it means early detection of objects or people that are moving at the side of the road. For example, with LED lighting, object detection happens 1 to 1 1/2 seconds earlier. In summary we can say the following: An LED light can generally



**Figure 1:**  
Relevant areas for the development of a modern street light

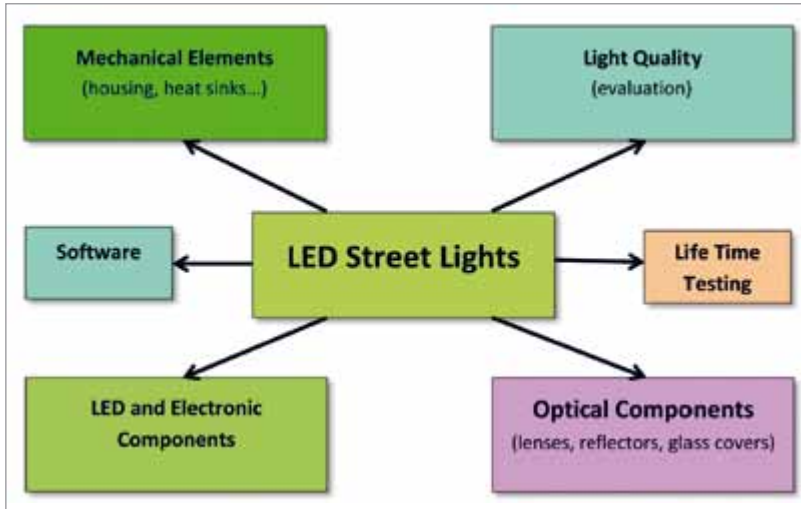

fulfill the visual tasks in roadway traffic better. Dimming is not an unavoidable scientific conclusion because dimming means that certain visual tasks cannot be fulfilled correctly.

**LED professional:** From the point of view of the standard, then, can we really carry out a night time shut off or a night time draw down?

**Prof. Khanh:** That is a very important and very hard question to answer. For economic reasons, it wasn't possible to dictate legally binding limit values in the standard. Because the norm is not a legally binding regulation, a community can deliberately not adhere to the standard. It becomes problematic if a legal inquiry is made in the case of a traffic accident because the standard has been formulated to coincide with the current state of the art, which means the responsible parties can be made liable.

**LED professional:** Generally, where do you see the advantages and disadvantages of LEDs in street lighting?

**Prof. Khanh:** As components, LEDs have a long life time if good thermal management has been taken into account and the construction of the electronic components has been carried out carefully. I have personally examined LED lights that failed after 5,000 – 7,000 hours. The reason was not the LED itself, but rather the implementation of the system which was carried out with insufficient

competence. The color rendering is also good enough and the dimmability and/or shiftability are big advantages. LEDs are virtually dot shaped light sources so that with optics (lenses, reflectors) the light is projected exactly in a targeted area. This cannot be done with discharge lamps like mercury arc lamps, sodium lamps or fluorescent lamps which are very big.

In a recent research project we compared the detection potential of road markings on the street at night, illuminated in the same conditions with white LED light and with yellow sodium lamp light. The conspicuity of the road marking illuminated with the LED-light is much better. This is a very good argument for the reduction of traffic accidents.

The disadvantage is certainly the cost of LEDs. Today the manufacturing costs for an LED lamp is at about 150-250 Euros which is the same as the sales price for a luminaire with conventional light sources. Even if you calculate the maintenance costs, you don't get a return on investment for at least 10 years. It is precisely the dimmability that could improve the point balance considerably.

**LED professional:** Isn't this a contradiction? Dim to reach the cost effectiveness of the LED lamp, but don't dim because we have to orient ourselves on the state of the art and the applicable norms?

**Prof. Khanh:** When we talk about dimming we must also look at the brightness control in twilight situations. If the light is dimmed at night we would really have a problem in an accident situation. Dimming can be understood in another way. Imagine that there isn't any traffic at all on a street all night long. Why would you have to have it lit 100%? Let's think of an ideal lamp. Why shouldn't the lamp concentrate on the pedestrian if there isn't any traffic on the street? It is only with the development of intelligent lamps that we can see even stronger advantages of LEDs in street lighting.

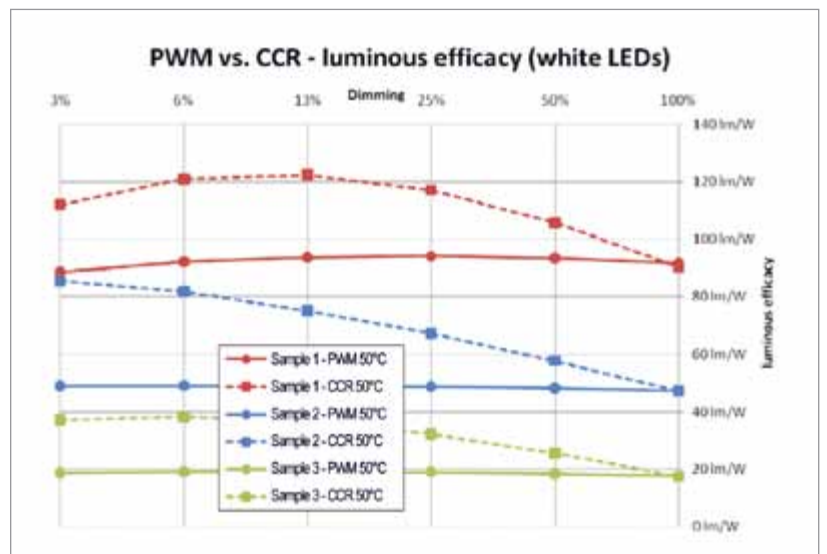

**Figure 2:** Efficacy of different LEDs dependant upon the dricing mode (PWM vs. Constant Current)



### Prof. Dr. Tran Quoc Khanh

Prof. Tran Quoc Khanh studied technical optics and wrote a Ph.D-thesis on the field of the optical spectroscopy. After 17 years in the industry, in which he developed the world's first digital cinema camera on the principle of CMOS and a cinema film scanner with LED-Chip on Board technology, he came to the University of Darmstadt, Germany in 2006. He is the chairman of the laboratory for lighting technology with the main fields in automotive lighting, street lighting and indoor lighting using LED-OLED technology.

**LED professional:** Let's stay with the subject of dimming for now. PWM dimming is thought of as the quasi-standard for LEDs. Yet, pulsed dimming can lead to miscalculations of distances in connection with moving objects. What is the current research opinion here?

**Prof. Khanh:** We started researching that about three years ago. Currently, we are working on a research project from a large automobile manufacturer and the German government concerning this topic.

The subject of dimming has been clearly underestimated. Older systems dim with, for example 100-200 Hz, which alone can lead to irritations.

3-4% of the population has problems with modulation frequencies at this level. There was the case of a person that had to stop his car in a tunnel because of the light modulation. The so-called Bailey's beads effect is also known which is created by the modulated tail light and the turning of the head when passing cars.

**LED professional:** We have a study on hand that says that all irritations and miscalculations can be eliminated at 400-500 Hz. Do you agree?

**Prof. Khanh:** At 300 Hz, 5% of the test persons could still feel the effects of the frequency modulation. At 500 Hz, the statistics show that there were no more effects on the test persons and therefore there is zero risk.

**LED professional:** Wouldn't it be advisable, then, to go completely away from PWM light and to use constant DC controlled light?

**Prof. Khanh:** This subject is currently being examined, namely with red and white LED light. Our results show an efficiency increase of 30-60% in the case of analogue dimming in comparison to PWM dimming,

whereby the color temperature in both cases changed a little, though color temperature with PWM dimming changed less. We therefore think that the analogue dimming method is quite suitable for LED-street lighting.

**LED professional:** Right now the subject of renewable energy sources is quite popular. How do you see the combination of LED street lighting with solar energy?

**Prof. Khanh:** We developed that type of luminaire for a big German luminaire manufacturer. This subject must be differentiated when looked at. Our examinations showed that, for example, the energy won from the sun in Germany could supply service roads and parking lots but not public highways. Of course, intelligent solutions can be applied here as well that monitor battery charges and then steer or dim the light accordingly at night.

**LED professional:** When using solar energy in street lighting it is practically always assumed that a battery will be used. How do you see using a hybrid system with the option of being able to feed able to feed of the AC-mains during the day?

**Prof. Khanh:** We actually thought about that solution and are working on it with the professorship of electrical engineering in Darmstadt. The LED professional Review (LpR) has an international readership. For this reason we had to think about the fact that countries in the south or even my native country, Vietnam, have enough sunshine to make solar lighting possible also as a hybrid version.

**LED professional:** Thank you very much for this fascinating talk.

**Prof. Khanh:** Thank you. ■

[www.osram-os.com](http://www.osram-os.com)

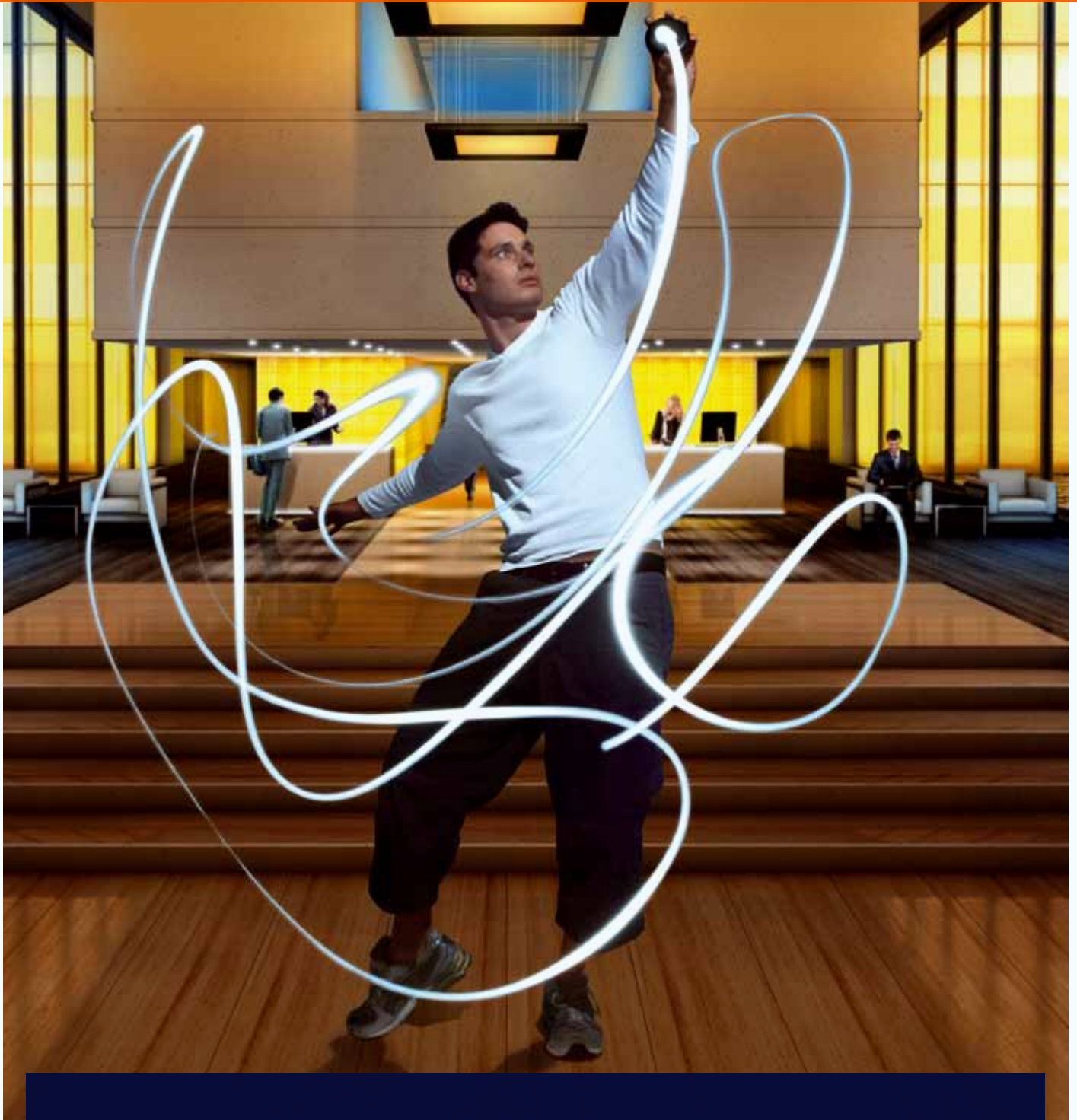

# LEDs for General Lighting Solutions

OSRAM Opto Semiconductors empowers lighting solutions for today and tomorrow

**OSRAM**  
Opto Semiconductors

# DC Microgrids and SSL - Key Components for Zero Net Energy Buildings

Brian T. Patterson, Chairman of EMerge Alliance and General Manager of Business Development at Armstrong World Industries, and Karen Lee, LC, LEED AP, Head of Applications Marketing at OSRAM SYLVANIA are giving an introduction in the aims of EMerge Alliance, standardization issues and the opportunities of LED lighting in combination with DC microgrids.

The quest for zero net energy buildings is likely to change a great deal about the way we approach designing and constructing buildings in the future. From the use of a broadened integration team in early planning and the heightened use of BIM tools to the consideration of a diverse pallet of energy efficient building solutions and site-based power generation and storage, the days of incremental improvement of older technologies may not meet the challenge. We need to start changing the way we fundamentally look at power, and we need to do it now.

Traditionally, we have had a very generation-centric view of electrical power. But the current strain on these systems collectively has resulted in an ever increasing number of critical supply mishaps. And although utilities are working hard to fix our problem, an

effort we call the “Smart Grid”, nobody predicts this will solve the underlying and growing shortage of electrical energy supply. The fact is we’re bleeding electrons moving at the speed of light. Energy consumption, like population, is growing faster than conservation alone will satisfy.

Some of that burden can be borne by being smarter about how we use energy in buildings. It’s not rocket science to understand that replacing incandescent and T12 fluorescent lighting with T8, T5 and LED lighting along with adding a few controls like dimmers and occupancy sensors can help. But natively direct-current (DC) powered LEDs increasingly used in the lighting of buildings gives rise to the troubling question, “how can we stop the waste of power associated with converting every watt of power for them from AC to DC?” Just as bad is that more and more of that power is generated locally by renewable sources like solar photovoltaic and

variable speed wind turbines that natively produce DC power, making power conversions a double negative!

Our current 100-year-old electrical power system is full of similar mismatches and power inefficiencies. Today’s digital world needs DC power at the device level. And if electricity storage is a factor, either to compensate for the non-dispatchable nature of most renewable energy sources or to back up critical mission functions like data centers and emergency lighting, multiple conversions of the same original power is necessary. Could we find a better way of wasting power?

However, nobody is suggesting we relive the Edison – Westinghouse battle of the currents. The tone is more moderate and focused on hybrid systems, systems that minimize conversion loss and improve overall reliability of the whole power system. This means change, real change in the way we deal with power at the building level. To minimize the growing problem of excessive power conversions in our power systems, we need to make greater use of native DC electricity in our power systems. By simply making thoughtful and deliberate changes in our systems over time, we can save an enormous amount of energy. And while we are at it, we can make LED lighting, and site-based renewable

**Table 1:**  
By introducing a DC grid energy saving opportunities in various applications are given

Building Applications <i>(in priority order of EMerge Alliance)</i>	Ave % of Building Energy Used	Potential Energy Savings by Going DC	Keys to Maximizing Efficiency in Going DC
Interiors (Lighting)*	28%*	Up to 15%	LED, Renewables
Data/Telecom	17%	Up to 30%	Higher voltage conversions, Renewables
Service/Utility (HVAC)	36%	Up to 10%	Renewables
Outdoor**	6%	Up to 10%	LED, Renewables
Other (misc equip loads)	13%	Up to 5%	Different voltage conversions

**Figure 1:**  
EMerge Alliance  
occupied space  
standard system

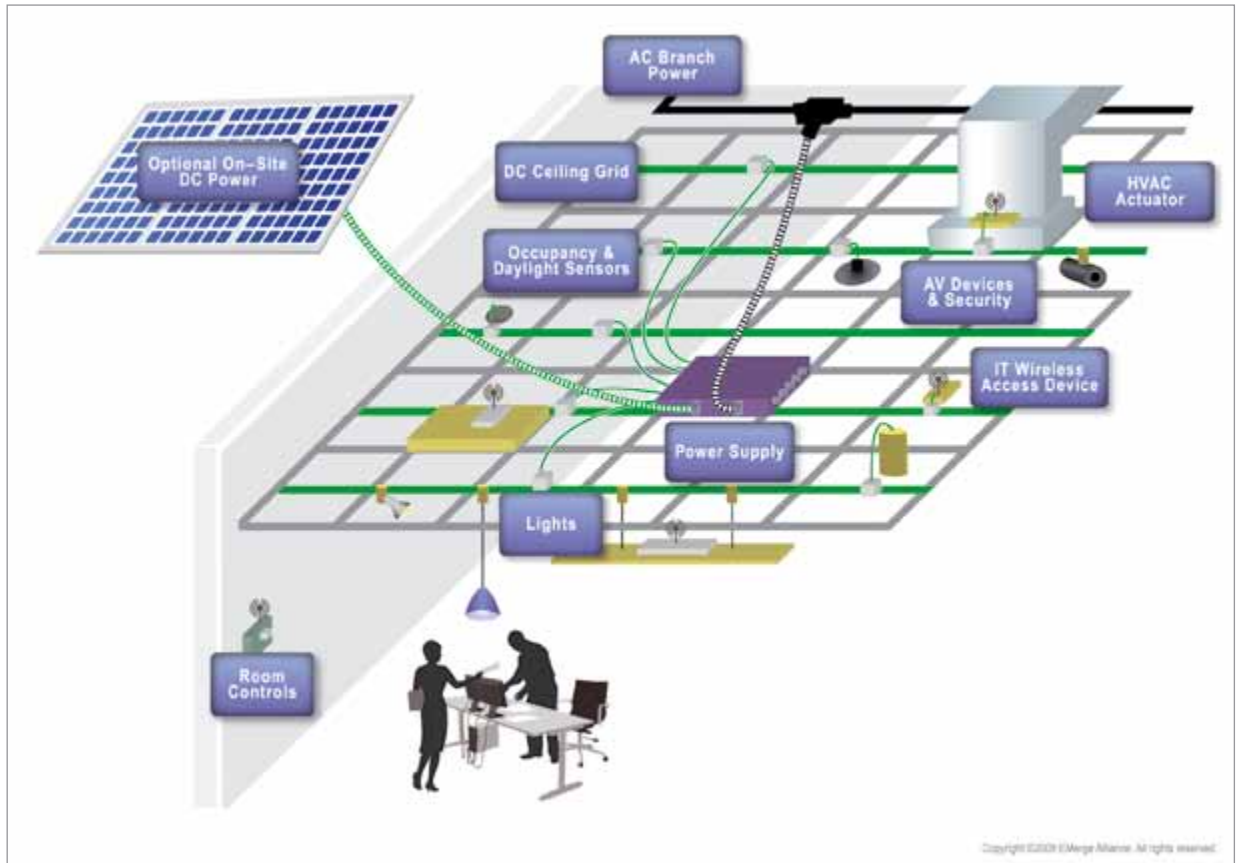

power generation and storage easier and more efficient to integrate. At the same time we can also increase user safety, provide low cost plug-and-play reconfiguration flexibility, and fundamentally improved equipment and system reliability.

But widespread use of DC will not happen automatically – the impediments to deployment need to be dealt with at a variety of levels and from a number of perspectives, not the least of which is the creation of application standards. To help organize this effort, an open industry, nonprofit organization called the EMerge Alliance was founded by companies like Johnson Controls, OSRAM SYLVANIA, Nextek Power Systems and Armstrong World Industries. These pioneers have been joined by companies including Philips Electronics, Emerson Network Power, Watt Stopper/Legrand, Tyco Electronics, Cooper Industries, Acuity Brands, Crestron, Hubbell, Leviton, Steelcase and a steady flow of other companies and organizations willing to help. These forward thinking companies are aggressively assessing

and addressing the needs of this emerging technology, including catalyzing the development of a robust supporting commercial eco-system and coordinating the review and revision of existing code and regulatory treatments with the help of organizations like Underwriters Labs, NEMA and NFPA.

The Alliance's collective vision is to create new, open standards for room- and building-level DC microgrids for commercial buildings that include the occupied space, data and telecom centers, building services and utilities, and outdoor power, including plug-in electric vehicle charging. The standards are targeted to complement the existing AC infrastructure and standards with a hybrid DC power layer at the generation, storage and device load level.

The proposed EMerge standards define safe low voltages (under 600 volts) for general power distribution and heavy plug loads and limited current potential very low voltage (NEC Class 2, under 30 volts) at the user

interface to enable shock and startle hazard free plug-and-play device flexibility. In all cases, the standards are being crafted to facilitate energy savings at all levels by avoiding unnecessary power conversions and maximizing the opportunity for highly articulated digital control.

### LED Lighting and DC Power Microgrids

As we strive to create LED systems that are well suited for general lighting applications, we find that the performance and technical parameters of collateral components, as well as the systems that feed them, are just as critical to the overall solution as the LED itself. As the efficiency of LED chips continues to improve at the rate of Moore's law, or doubling efficiency every 18-24 months, more attention is focused on the other parts of the system and the performance expected from a lighting perspective. If we remind ourselves first why LEDs are so interesting for general lighting applications, it will not be difficult to see how DC power operation can compound the benefits.

**Figure 2:**  
**Example for the**  
**Zero Net Energy**  
**Buildings -**  
**building level**  
**DC microgrid**  
**with renewable**  
**and alternate**  
**distributed**  
**generation feeds**

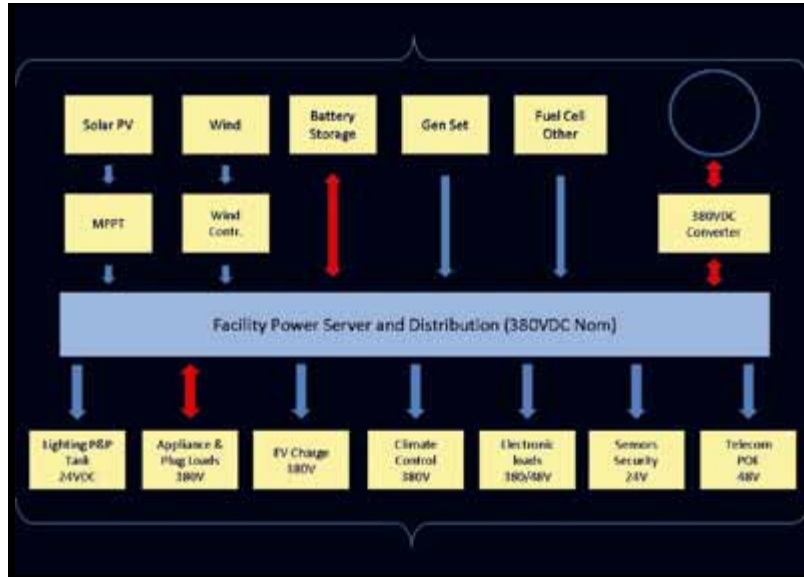

LED technology has become the darling of the lighting industry because of the promise to drastically cut energy consumption, particularly in commercial buildings. As energy codes and programs such as LEED become increasingly more stringent, lighting power density restrictions become more challenging to meet – particularly if good quality lighting design is to be maintained. According to the DOE, lighting can consume up to 30 percent of all electricity in commercial buildings. Part of the energy savings will come from the efficacy of the LED itself. Compared to the incandescent lamp that offers a mere eight lumens for each watt of power consumed, today's premium LEDs can offer 10 times that amount, when operated in a well designed environment – or up to 20 times that amount in perfectly controlled laboratory conditions. That's a good start, but not enough to surpass the lumens per watt performance of today's best fluorescent lighting systems that dominate commercial building spaces. Why all the fuss then, you may ask?

The other aspect to consider in the energy efficiency story is the efficiency of the luminaire. It does no good to generate light very efficiently if it gets trapped in the fixture and never makes it to the task plane to actually provide illumination. For some of the most common luminaire types used, troffers and down lights, for example, fixture efficiency can be as low as 60 percent.

With LED technology, the expectation is that fixture designers will harness the native directional nature of LEDs and produce luminaires that have near perfect utilization of the light that is produced, guiding each and every lumen along the most direct path to the task at hand. With efficient optical systems, the need for large reflectors or refractors should be minimal, thereby reducing bulk and cost and increasing design flexibility.

Beyond energy efficiency, the unique form factor of LED technology brings an entirely new dimension to architectural design flexibility. Gone are the size limitations of fragile glass packages wrapped in fixture reflectors or refractors. Small, rugged LED packages may be arranged in endless configurations and be regarded as building materials rather than utilitarian providers of visibility. Build lighting into floors, walls and furniture? Make light appear as if it comes from nowhere? Why not?

Another intriguing aspect of LED technology is the relative ease with which it may be controlled. There are no warm-up time or hot restrike issues to mitigate, making operation on occupancy sensors a natural fit. As semiconductor devices, LEDs are well suited to extremely low temperatures, making them ideal for applications in many outdoor or uncontrolled environments. As building codes and best practices move to requiring control systems and dimming or as

bi-level switching is used in more applications, this issue will become of increasing interest. From a design perspective, as well, the ability to offer varied light levels or dynamically changeable color broadens the creative palette even further.

This bold new world, however, does not come without its challenges. While initiatives such as the Zhaga Consortium are trying to add some order to this exploding new lighting portfolio, the fact is that limited standards and industry guidelines are available. There is no accepted counterpart to the familiar medium screw (E26) or the bi-pin base/socket combination. There are mounting holes spaced –well –somehow. There are connectors that are available today, if you can figure out who made them. With a technology that is advancing at such a rapid rate, the issue of being able to replace or upgrade LEDs in the future to repair early failures, change color or beam spread, or take advantage of improved efficiency, becomes an extremely difficult and worrisome task. While some manufacturers have developed their own connector systems for replaceable modules, they are not universal, so an installation would be limited to that one company if a complete luminaire replacement was not an option.

Considering the opportunities LED technology can offer to the design, aesthetics, operations, and maintenance of building, all can be positively impacted by the adoption of DC power grids as a component of the overall building infrastructure. At the luminaire level, locally available DC power eliminates the need for a power supply to convert the AC line voltage to be usable by the LED devices, which results in one loss mechanism and improves efficiency of the fixture by up to 15 percent. Multiply that savings by the number of lighting fixtures and other electronic devices in a building, and the savings can be quite significant. For sites that have on-site renewable energy sources, yet another DC-to-AC power conversion step, with its associated losses, is avoided. As luck would have it, many of those

# Super-flat SMD-LED

with height of just 0,25mm



## KPG-1608 series

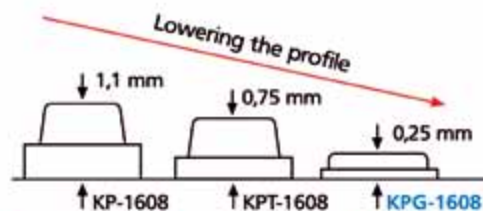

**Quality — Efficiency — Innovation — First-class service**

Kingbright Electronic Europe GmbH • Lindenau 7 / Gewerbegebiet • D-47661 Issum • Phone: +49 (28 35) 44 46-0 • Fax: +49 (28 35) 44 46-29

electronic components eliminated in that front-end conversion are those responsible for limiting the life of LED systems today, so overall system reliability improves as an added bonus. In many cases, it is not the light-emitting diode that fails in the system, but the power supply or other electronic component responsible for controlling performance.

From a building operation and maintenance perspective, the benefits of DC power grids go beyond decreasing energy consumption to reducing labor costs and business interruptions. With a distributed power grid bringing low 24-volt DC power throughout a space, several safety and maintenance practices become much easier. When a need to change furniture or traffic patterns in an area arises, a modification in the lighting design often comes with it. This might typically require significant rewiring or new circuits and re-commissioning of control systems by skilled electricians, including provisions for temporary lighting while the system is being reconfigured. With a DC power grid based on the EMerge standards, however, the pluggable busses are already distributed throughout the space and only a physical reconfiguration of fixtures and software reprogramming would be required, particularly with the wireless control systems available today. Additional or upgraded fixtures may be easily added without new wiring, since power would be drawn from the electrified ceiling grid already in place. At this low voltage, luminaires may be relocated

without the need of shutting down the entire circuit, a technique called “hot-swapping,” and the fixtures do not require separate high-voltage disconnects. Where the task is simply troubleshooting or repairing a single fixture, safe and speedy maintenance can take place without disruption to normal business operations. If you are a property manager welcoming a new tenant or a business accommodating a new working group, this capability can be a very welcome change that represents valuable time and labor savings.

EMerge standards for the occupied space call for very low, touch-safe voltages. With traditional and/or home-run wiring conventions, this normally results in a concern for power loss in the resultant long wiring runs. But the unique wiring topologies of the standard address this concern by using a “hub and spoke” wiring method that inherently shortens any given wiring run. The standard specifically limits individual spoke lengths to avoid this situation. The power hubs feeding power to the electrically isolated spokes are strategically distributed throughout the space. Each hub is wired to higher voltage AC and/or DC distribution with even less loss. This feed layer in the grid topology can use existing building wiring or can involve new wiring as part of the building’s DC microgrid, which combines the direct on-site use of renewable and alternate energy sources.

## Using “Smart” DC Microgrids

According to the Zero Energy Commercial Buildings Consortium final report [1], “DC microgrids would fundamentally change the way power is supplied in commercial buildings, eliminate AC-DC conversions at the equipment level, simplify equipment designs and layouts, provide improved interfaces with renewable energy sources and storage, and save energy.”

### That’s because DC microgrids can provide for the following:

- **Energy Savings** – while the amount of savings in electrical energy is somewhat difficult to completely capture, a Yale published research estimate [2] puts the annual potential reduction at more than eight percent of the total national electric load, or approximately 400 million kWh per year. This does not take into account additional energy savings as a result of less cooling being required in buildings where fewer electronic conversion devices are used.
- **Renewable Energy Integration** – DC microgrids facilitate simple and more energy efficient coupling (eliminating the need for multiple inverters/converters) of distributed alternate and renewable energy generators (solar, wind, fuel cell, etc.) that natively produce DC power. Industry sponsored research [3] at the Electric Power Research Institute (EPRI) has concluded that multiple distributed source generation

coupled onto a common DC bus can simplify and make more efficient the use of site-based alternate energy.

- Energy Storage** – Local energy storage will be essential to the widespread use of non-dispatchable distributed energy generators. The distributed bus architecture of DC microgrids allows simple and more energy efficient coupling of natively DC (batteries, Ultra capacitors, etc.) electricity storage.
- Control & Monitoring** – Most modern controls, sensors and monitoring systems natively run on DC current and are digitally and/or microprocessor based [4]. The use of DC microgrids therefore greatly simplifies the electronics involved with electrical and energy system control and monitoring by eliminating the need to convert AC power to operate.
- System Reliability** – The intrinsic redundant, disaggregated topology of DC microgrid networks assure a higher level of basic service reliability. By being ‘islandable’ both public grid and the individual microgrids can be isolated from one another during other dynamic and damaging linear failure events and disturbances. The reduction in subsystem and device-level power conversion/inversions generally improves ‘mean-time-to-failure’ levels in the equipment.
- BEV/PHEV Integration** – As electric vehicles begin to populate our national automotive fleet, plug-in charging and their potential use in providing supplemental storage or electricity back-up capability, electric power grids will increasingly need to accommodate this shift in energy distribution and use. Since these vehicles run on pure and modulated DC electric systems, DC microgrids will more easily provide for their charging (including fast DC charging) and storage connectivity needs, again with fewer wasteful power conversion/inversion steps.

Proponents of DC microgrids, including members of the EMerge Alliance, believe they can provide a new dimension of utility and efficiency to improve our electrical energy system. They further maintain that they are a critically needed addition to the work and goals of the current smart grid overhaul. DC microgrids hold the potential to change the paradigm of a centralized power generation and distribution system to one more akin to the distributed network configuration of the Internet. As such, we could expect it to be more flexible, accommodate greater innovation and generally be more accommodating of the power sources and loads that have come to be and will continue to develop.

### About the EMerge Alliance

The EMerge Alliance is an open industry association leading the rapid adoption of safe DC power distribution via DC microgrids through the development of EMerge Alliance standards.

Vision: DC Microgrids Throughout Buildings



**Figure 3: The vision for DC microgrid throughout buildings**

These innovative standards integrate infrastructures, power, controls and devices in a common microgrid platform to facilitate the hybrid use of AC and DC power throughout buildings for unprecedented design and space flexibility, greater energy efficiency and improved sustainability. The nonprofit Alliance is accepting new members at various levels. ■

### References:

- <http://zeroenergycbc.org/pdf/CBC%20Technologies%20Report%202011.pdf>
- <http://environment.research.yale.edu/documents/downloads/0-9/05-DC-Microgrids.pdf>
- <http://www.emergealliance.org/imwp/download.asp?ContentID=19276>
- <http://www.emergealliance.org/imwp/download.asp?ContentID=19272>





# TAITRONICS

37<sup>th</sup> Taipei International Electronics Show

In conjunction with

 **BROADBAND TAIWAN**

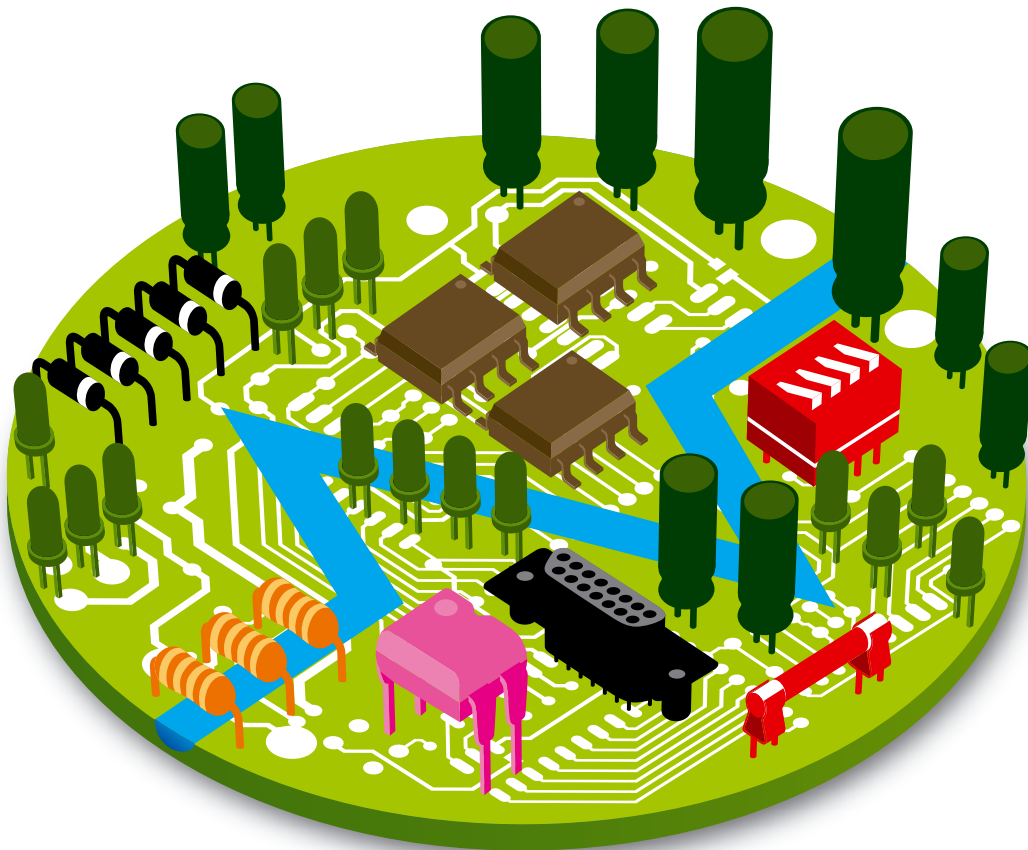

Electronic Components · LED  
Test & Measurement · Processing · RFID

**OCT.** 10-13  
**2011**

TWTC NANGANG Exhibition Hall  
TAIPEI, TAIWAN

[www.TAITRONICS.org](http://www.TAITRONICS.org)

Organizers:



**TAITRA**



**TEEMA**

# LED Driver Innovations for High-Performance Signage

Toshiba's Marketing Manager for Consumer and Industrial ICs, Roland Gehrman explains how new generations of driver ICs are overcoming challenges of today's large LED signs, where many thousands and sometimes millions of LEDs, often arranged in groups of red, green and blue that act as a single pixel.

**Figure 1:**  
Multi-channel  
LED control via  
microcontroller  
serial interface

Designers of digital signage are taking advantage of the increasing performance of high-brightness LEDs to tackle ever more ambitious projects. Today's large LED signs can contain many thousands and sometimes millions of LEDs, often arranged in groups of red, green and blue acting as a single pixel. Large LED arrays such as these, present tougher and more wide ranging control challenges compared to small-scale signage or backlighting applications. The brand new generations of driver ICs, which are subject of this article, are overcoming these challenges.

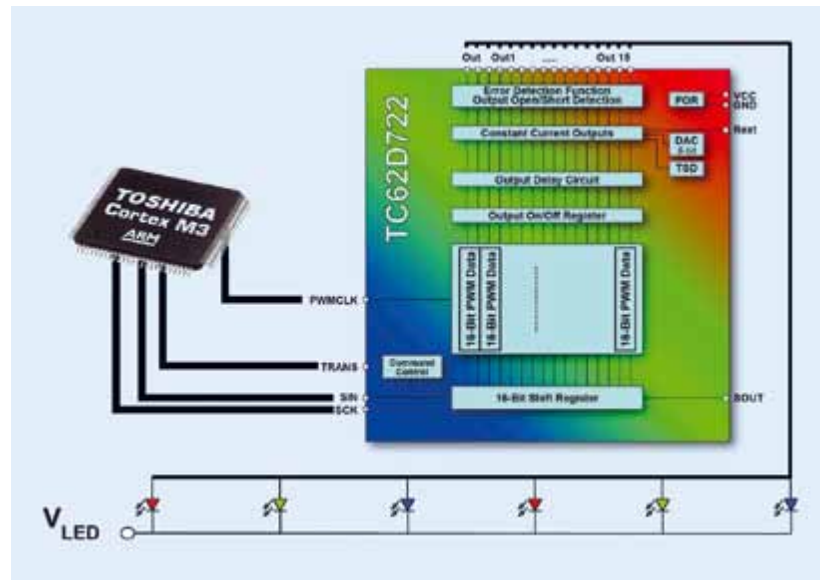

## Extra Channels: Extra Challenges

Figure 1 illustrates how a multi-channel driver is used to supply constant current to a group of LEDs, receiving high-level command signals from the host system microcontroller. Drivers with eight, nine or sixteen channels are typical today, and 24-channel devices will become commonplace in the future. Even so, several thousand drivers may be needed to control the entire LED array in a large signage solution such as stadium advertising or a public noticeboard.

LED brightness and emitted wavelength vary according to supplied current. For this reason, constant-current drivers are the preferred solution in large multi-LED applications where consistent optical output is

required. Close matching of driver output current - from channel to channel, and from driver to driver - becomes extremely important when designing very large LED signs.

## Enhancing Visual Impact

Channel-to-channel current matching to within  $\pm 3\text{-}6\%$  has traditionally been adequate for many applications. However, as signage dimensions grow, driver ICs targeting large multi-LED applications must deliver greater precision. The 16-channel Toshiba TC62D722 driver, for example, has channel-to-channel matching to within  $\pm 1.5\%$ . Importantly, IC-to-IC output matching is also within  $\pm 1.5\%$ , which gives designers extra confidence to create large-size displays with high pixel density and requirements for large numbers of driver ICs. Moreover,

closer matching between channels and drivers allows designers to achieve acceptable optical performance with lower-cost LEDs, which can have a relatively broad spread of parameters from device to device.

LED output power continues to increase with improvements in current-handling capability. At the same time, signage designers strive to create larger, brighter displays providing greater effective viewing range. As a result, suitable drivers must be capable of supplying higher maximum output current. Drivers must also be able to maintain close control over driving current as the output voltage to the LED varies. The TC62D722 has output adjustment range from 1.5 mA to 90 mA, with a flat current characteristic over a wide output voltage range (Figure 2).

**Figure 2:**  
Improved  
constant-  
current drive  
characteristic for  
high-power LEDs

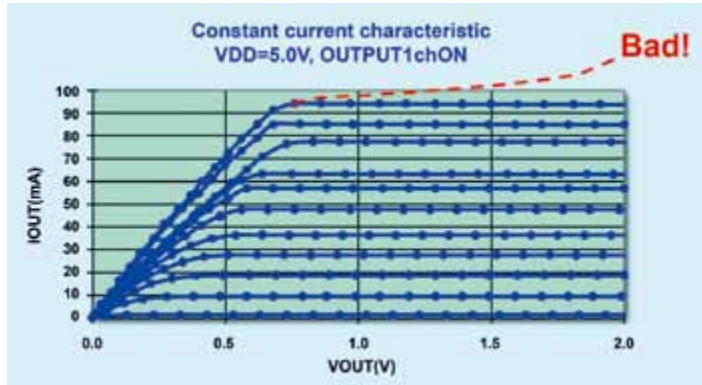

### Simplifying Power Design

Integrated output delay is another feature assuming greater importance in the context of ultra-large LED signage. In a large display it is normal to connect the drivers controlling blocks of up to 64 LEDs to one power supply and switching on a large proportion of these LEDs simultaneously imposes high peak demand. The worst case would be if all the LEDs in a multi-million LED display were switched on simultaneously; this would call for a relatively large and expensive power architecture capable of supplying a very high peak demand.

One way to prevent sudden, large current fluctuations is to implement edge-rate control for each channel. This limits the change in current as the outputs are enabled or disabled. Alternatively, the output-delay technique automatically inserts a short time period to stagger the turn on of each channel. This reduces the peak power demand per driver, reducing power surges and allowing the use of smaller, lower cost, power supplies.

### Noise Abatement

Switching of large numbers of LEDs also tends to generate noise and ringing on the output channels. This can interfere with the driver's own circuitry, and that of adjacent drivers, as well as presenting EMC compliance challenges. Addressing these

issues in a large display panel has typically involved the use of large numbers of external components such as capacitors to flatten spikes and damp oscillations. Newer generations of multi-channel drivers for high-output signage applications, however, have integrated circuitry to combat switching noise. This reduces the need for external components, which simplifies design and assembly, reduces cost and improves overall reliability.

### Solving Flicker

In dimmable signage where animations or frequently changing images are displayed, the dimming PWM output cycle must be fast relative to the image update rate. Consider a dimmable driver with 16-bit dimming resolution. If a PWM clock frequency of 30 MHz is applied, the PWM output rate would be 458 Hz. If moving images are to be displayed, this frequency is close enough to the image update rate to produce a noticeable flickering. Increasing the clock frequency to raise the PWM output rate would increase noise, power and thermal issues, as well as cost.

A new Division PWM technique effectively increases the PWM rate without an attendant increase in clock frequency. With Division PWM, given the same 30 MHz frequency and 16-bit dimming resolution, the 2.18 ms PWM output cycle (1/458 Hz) is

Perfection & competence

LED-heatsinks from

fischer

elektronik

- versatile product range of LED heatsinks, excellent thermal geometries for natural or forced convection
- special profiles, customised machining and modifications for your specific application



**Extruded profiles**  
compatible for all established LED-types,  
case profiles with integrated guide grooves

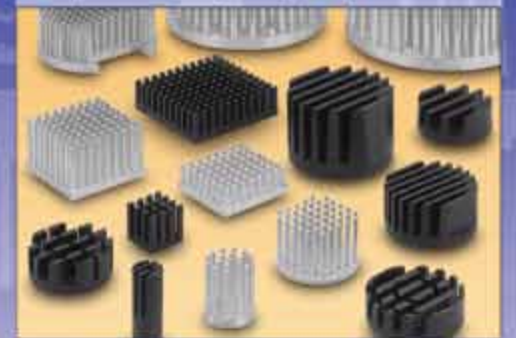

**Round and pin heatsinks**  
aerodynamic omnidirectional fin geometry,  
flat LED mounting area, low weight



**Customised LED heatsinks**  
competence in "Thermal Management" for LEDs,  
in-house measuring lab for thermal analysis

P. O. Box 1590 D-58465 Lüdenscheid  
Nottebohmstraße 28 D-58511 Lüdenscheid  
Tel. +49 23 51 4 35-0 Fax +49 23 51 4 57 54  
info@fischerelektronik.de  
www.fischerelektronik.de

Cases  
Heatsinks  
Connectors

**Figure 3:**  
Division mode  
PWM combats  
flicker in dimmed  
signage displaying  
moving images

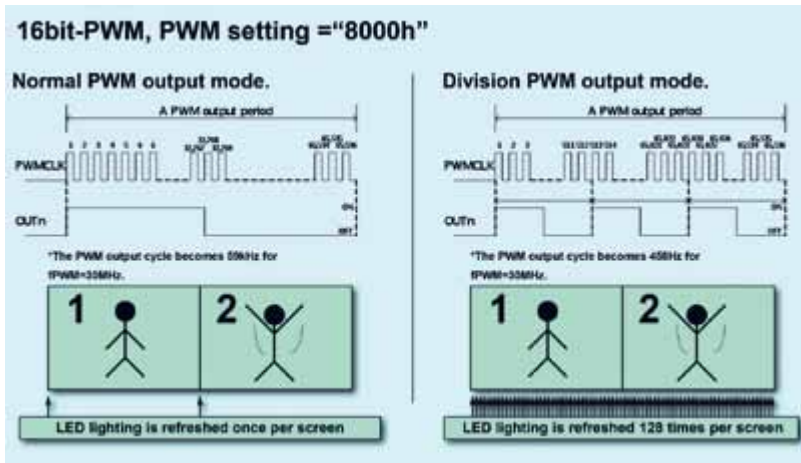

divided into 128 sections each corresponding to 512 clock cycles. The PWM duty cycle needed to achieve the selected dimming level is replicated within each division period, effectively increasing the PWM output rate from 458Hz to 59kHz and so eliminating the problem of flicker when displaying moving images.

Division PWM is particularly suited to drivers like the TC62D722, since this device does not use output edge-rate limitation to combat switching noise. The device also supports normal PWM as well as Division PWM modes. These are set using an internal register, and the driver also permits setting 16-bits, 14-bits, 12-bits or 10-bits PWM resolution. Figure 3 illustrates Division PWM compared to normal PWM operation in the TC62D722.

### Power Management

As the size and performance of LED signage products continue to increase, power management within the LED driving subsystem is growing in importance. High energy prices are causing signage buyers and operators to consider power consumption as part of the decision making process. Power-hungry signage is also unattractive to organisations focusing on reducing their carbon footprint.

A multi-channel driver designed for signage applications may typically draw a few milliamps in its quiescent state. In a large display comprising, say, 1000 drivers operating at 5 V, this translates into a total power drain of 35 W, even when no LEDs are lit. With this in mind, the use of power management modes is likely to become commonplace in LED signage designs of the future.

To support power management in energy-conscious applications the TC62D722 provides a standby mode. The mode is controlled from the application software by setting a bit in an internal register, and reduces the IC's current draw to below 1  $\mu$ A. This could enable designers to reduce quiescent power consumption of up to 35W, in the example discussed earlier, to a standby Figure of 5 mW, realising benefits both in terms of energy usage as well as the cost and sizing of the power architecture.

### Improving Diagnostics

Error reporting including identification of faults such as LED failures is especially important in LED signage applications where extremely large numbers of LEDs are used. Although LEDs are known to have long lifetimes compared to incandescent bulbs, factors such as vibration and high temperatures can produce

open-circuit or short-circuit failures in individual LEDs throughout the array. Where several LEDs are connected in series as a string, a single open-circuit failure can result in the entire string failing. Sometimes, failsafe shunt devices may be fitted to bypass an LED in the event of an open-circuit failure and so allow other LEDs in the string to continue operating. Integrating protection features within the driver IC saves external components and can allow the type of fault and its location to be communicated to the controlling application.

In the TC62D722, two internal comparators are implemented at each output, to detect the effect of a short- or open-circuit LED on the voltage at the output pin. The status of the open- and short-circuit comparators is recorded in an internal shift register, allowing the driver to indicate the exact nature of an LED fault via its serial data output pin. Thermal shutdown protection and a power-on reset function are also provided.

### Conclusion

High-brightness LEDs for signage and lighting have been adopted enthusiastically for use in a variety of environments. While simple LED drivers using principles established with low-output indicator-type LEDs will continue to be used in numerous roles, more advanced applications require new approaches and greater feature integration. High-performance signage incorporating thousands or even millions of high-brightness LEDs are among the most demanding of these. Small improvements to aspects such as power management and noise reduction are already enabling system performance to move up to the next level. ■

# Bringing the Power to Light™ with Simple HBLED Drivers

## High Brightness LED Drivers with High-Side Current Sense

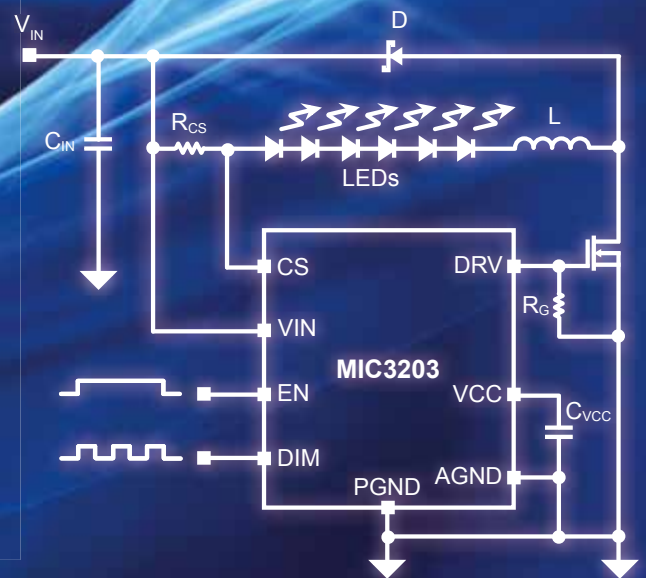
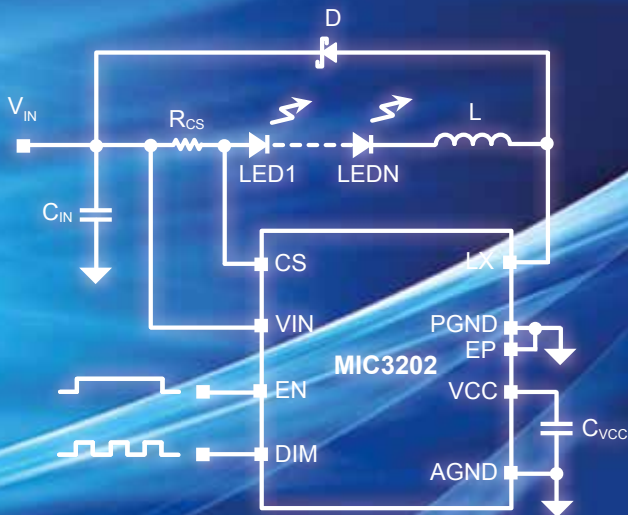

### Applications



The rapid growth of LED lighting applications in commercial, industrial and automotive markets has led to a wide variety of technical challenges for LED Drivers. Micrel is meeting these challenges with simple step-down LED Drivers such as the MIC3202 and MIC3203.

The MIC3202 is a hysteristic step-down LED Driver with integrated MOSFET capable of driving up to 10 HBLEDs with constant currents up to 1A in a thermally enhanced exposed pad SOIC-8L package.

The MIC3203 is a hysteristic step-down LED Driver with an external MOSFET capable of driving up to 10 HBLEDs with power levels up to 40W in a SOIC-8L package.

For more information, contact your local Micrel sales representative or visit Micrel at: [www.micrel.com/ad/leddrivers](http://www.micrel.com/ad/leddrivers).

### Ideal for use in:

- ◆ 12V Lighting Systems (MR-16 Bulb, Under Cabinet Lighting, Garden/Pathway Lighting)
- ◆ Architectural, Industrial, and Ambient Lighting
- ◆ LED Bulbs
- ◆ Indicators and Emergency Lighting
- ◆ Street Lighting
- ◆ Channel Letters

Part Number	Input Voltage	Output Current	PWM Dimming	Dithering	Package
MIC3202	6V to 37V	1A	Yes	Yes	EP SOIC-8L
MIC3202-1	6V to 37V	1A	Yes	No	EP SOIC-8L
MIC3203	4.5V to 42V	Controller	Yes	Yes	SOIC-8L
MIC3203-1	4.5V to 42V	Controller	Yes	No	SOIC-8L

**MICREL**  
Innovation Through Technology®

[www.micrel.com](http://www.micrel.com)

# LED Cooling in Harsh Environments with Synthetic Jet Technology

Dr. Markus Schwickert, Director of Reliability and Brandon Noska, Application Engineering Manager at Nuventix discuss different reliability issues of active cooling. Test procedures and results to prove longevity of sophisticated active cooling systems are presented.

Lighting is rapidly transitioning from traditional lamp sources such as high-pressure sodium, metal halide, mercury vapor, and fluorescent to high brightness light-emitting diodes (HB LEDs). In fact, illumination was the second fastest growing application for HB LEDs in 2009, with a growth rate of 28.6% over 2008, and this trend shows no signs of slowing. Architectural lighting, combined with commercial/industrial sectors and the outdoor sector, account for 54.3% of the illumination market [1].

Along with general illumination products, LED outdoor lighting needs proper thermal management in order to utilize the many advantages of LEDs such as a long L70 lifetime, instant on, better optical control, and, most importantly, low maintenance and reduced energy usage. Outdoor products cover a wide range of installations including wall washing, parking lot, area lighting, roadway lighting, and garage lighting, to name a few. Some of these form factors have enough surface area to allow for effective natural convection cooling, but pose other issues such as weight and large surfaces which are not good for shipping, handling, installation, and wind loading. Other form factors such as retrofit lamps are bound by existing infrastructure and need to remain

compact in order to fit into existing sockets. In all cases, if a reliable technology for forced convection cooling was available, designers would have more options to provide the proper lumen outputs while having small, lightweight designs.

Industrial and outdoor applications pose other challenges in addition to the thermal management requirements. Components need to be rugged in order to operate properly and to survive the elements. Although traditional air movers such as axial fans could provide an adequate forced convection thermal solution, this article will focus on synthetic jet cooling technology, which is an alternative air moving technology for forced convection cooling. This article looks at synthetic jet technology as a rugged and reliable forced convection cooling solution that could be used in harsh environments to ensure effective thermal management solutions.

## Synthetic Jets

Although synthetic jets have been known and researched for many years, synthetic jet products are relatively new to the market. Synthetic jets are formed by creating a periodic suction and ejection of fluids through an orifice generated by an oscillating diaphragm in a cavity surrounding the diaphragm. The jets are “zero-mass-flux,” thus there is no need for ducting or piping

in the medium for cooling. When these jets are directed at heat sink surfaces, they remove the heat much more efficiently than natural convection [2,3,4].



**Figure 1: Synthetic jet engine with oscillating diaphragm**

Synthetic jets can be generated in many ways, but one mechanism is the use of electromagnet actuators which create the driving force for oscillating the membrane. As the membrane oscillates within the cavity, synthetic jets are created at the nozzles that are around the cavity. There are many advantages to using electromagnetic actuators including no moving parts in friction, no lubricants, and no bearings to wear out. These inherent design differences between synthetic jets and traditional air movers such as fans and blowers are what differentiate these products in terms of ruggedness and

**Figure 2 / Table 1:** Natural convection versus forced convection. The table shows comparison data for natural convection versus forced convection

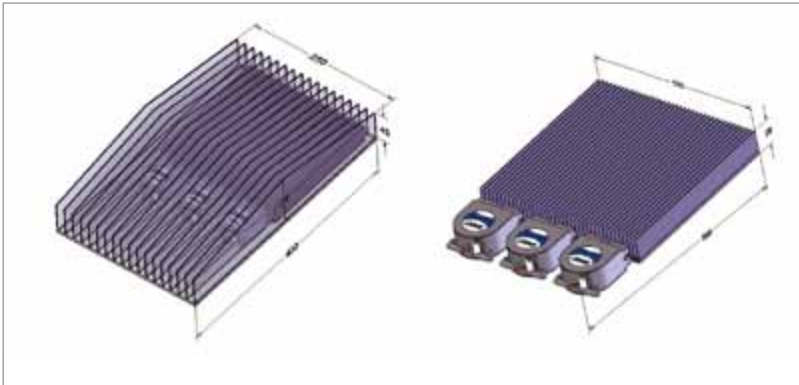

Metric	Natural Convection	Forced Convection	Improvement
Form Factor Volume, cm <sup>3</sup>	5640	1400	75%
Weight (kg)	3.0	1.4	53%
Thermal performance $\theta_{sa}$ , C/W	0.25	0.2	20%

lifetime. The main failure mode of fans and blowers is lubricant breakdown. This does not exist in synthetic jet products [5,6].

**Benefits of Forced Cooling**

Synthetic jet cooling allows for smaller form factors, lower operating temperatures, and dynamic airflow control for effective temperature control of the LED heat sink.

Synthetic jets have been shown to have higher Nusselt numbers, hence higher effective heat transfer, over conventional ducted flows by a factor of six or greater at the same channel Reynolds number. In addition, when comparing the thermal resistance of a heat sink ( $\theta_{s-a}$ ) cooled by synthetic jets or ducted flow at the same volumetric flow rate, synthetic jets have demonstrated as much as a 40% improvement in thermal performance. When compared to natural convection, synthetic jets have demonstrated 300% thermal improvement with the same form factor heat sink [7].

The higher heat transfer capability at low flow and significant improvement over natural convection is due to the turbulent vortex dominated jet flow which enhances the mixing of the thermal boundary layer and allows for improved thermal performance. For example, Figure two compares a 100 W design with forced convection cooling and natural convection cooling.

The forced convection cooling provides a 20% reduction in thermal resistance ( $\theta_{s-a}$ ), with a 75% reduction in volume and 53% reduction in weight.

The Evluma 40 W LED replacement lamp / luminaire for outdoor NEMA Type 5 fixtures is an example of a synthetic-jet cooled product available on the market today. This product replaces existing mogul base 50-175 W mercury vapor or 70-150 W high pressure sodium lamps. Evluma's 40 W LED lamp is an example of a product that utilizes forced cooling to dissipate 40 W, while keeping the form factor small for retrofit applications.



**Figure 3: Evluma's 40W LED Clearlight**

Although the use of forced cooling has many benefits as listed above, there are several elements that need to be considered for outdoor lighting. Typical requirements include IP 55 for electronics and other components, IP 67 for optical compartments, ability to withstand wash downs, to be cleaned, large temperature extremes, vibration due to wind loading and roadway vibrations. An effective outdoor LED light requires components that can withstand such elements. Synthetic jets offer a rugged and reliable solution. Synthetic jets are typically tested against high temp/high humidity, shock/vibration, dust, and power cycling [8].

The next sections highlight the various testing that is conducted on synthetic jet devices and the importance of this testing:

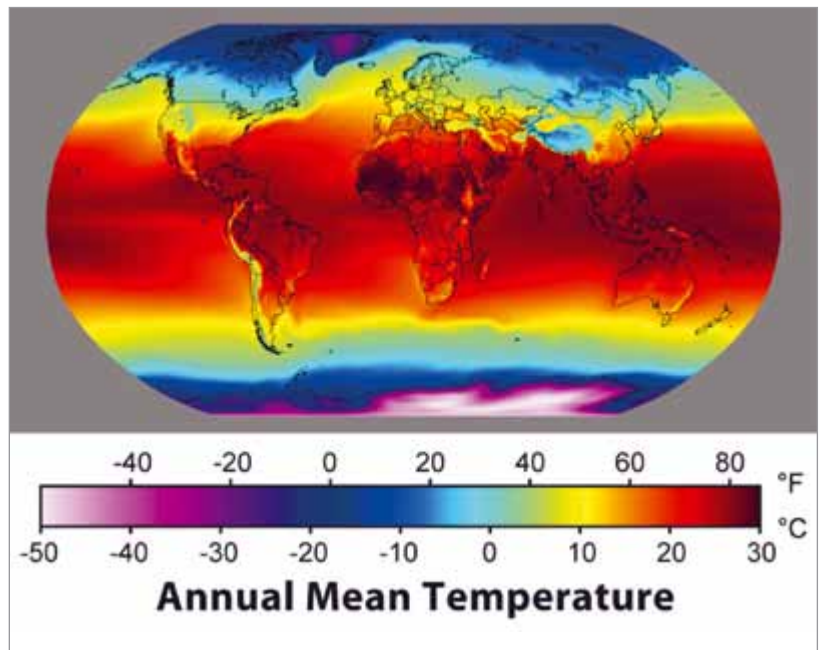

**Figure 4: Annual average temperature map, source Wikipedia.org**

## Reliability

The local environment of a cooling solution in an outdoor light fixture depends very much on the construction of the enclosure and the location and orientation of installation. Earth atmospheric temperatures typically range from -40°C to +40°C and can reach over +55°C in extreme conditions. Variations occur in day/night cycles and throughout the seasons while the relative humidity (r.h.) can range from nearly 0 to 100%.

Furthermore, pollution (e.g. acidic atmospheres, pesticides, cleaning solutions, building materials), ozone, UV light, and naturally occurring substances in the atmosphere (e.g. dust, pollen, insects) will interact with light fixtures and may reach internal components such as the LEDs, electronics, drivers and cooling solutions, impacting functionality or lifetime. Generally, harsh environments can not only be found outdoors, but in some industrial settings or specialty applications (e.g. aquariums, commercial kitchens, automotive etc.) as well.

Even ratings for ingress protection (IP) will not reveal how the lifetime of a product is affected by harsh environments, but rather testify to its safety and ability to function under those conditions in the short term. Here we focus on the cooling solution of a luminaire which must exceed the lifetime of the LEDs by far so that it contributes positively to the overall lifetime of the luminaire via extension of the LED lifetime, and does not limit it further [9].

Given the unique requirements for all different products and environments, there is no standard or set regiment of testing that can guarantee outdoor suitability across the board. Moreover, a robust product with reliability designed in must be measured up to the intended usage environments from the early design phase through the production release. A thorough review and qualification of the subcomponents, materials and even processes used in manufacturing is a must when designing for reliability.

As a result, the latest SynJet family of products, synthetic jets commercialized by Nuventix, has eliminated all structural adhesive joints, and all materials and components must pass a 60 hour autoclave test (Highly Accelerated Stress Test, HAST) at 123°C, >95% r.h. and 2 atmospheres pressure.

With input from numerous customers who inquired about outdoor usage, Nuventix has developed a platform-based comprehensive qualification test matrix for synthetic jet products that helps in predicting long-life performance under all realistic conditions, some of which are discussed below.

## Freezing Rain Cycle Test

This cyclic test is designed to address the repeated wetting and freezing of a product. In an environmental test chamber the test starts at standard ambient temperature (+25°C) with >95% r.h. followed by a sudden drop to -10°C to condense water on the unit and freeze it. After 10 minutes of freezing the unit is powered on for five minutes and then operation is validated. This is repeated a minimum of 100 times.

## Thermal Cycling

Thermal cycling, besides exposing the materials to a wide temperature range, addresses designs with mismatched coefficients of thermal expansion (CTE) and stresses joints and material properties. By going 200 times or more between -40°C and +105°C, soaking for an hour at each temperature and ramp rates of 5°C/minute with no failures allowed, this test adds to the confidence needed for a robust product in harsh conditions.

## Humidity

The effects of high temperature and high humidity can be surprising. Two major areas are affected: plastic material degradation and metallic corrosion. All synthetic jet types are tested for a minimum of 2,000 hours at 85°C and 85% r.h. with no failures allowed.

## Cyclic Condensing Humidity

Very hot and humid conditions are not as realistic as cyclic humidity conditions with condensation which can be achieved by cooling a device and then subjecting it to warmer, humid air (similar to taking a water bottle out of a refrigerator which will typically condense a lot of water from a sufficiently humid atmosphere). During the morning hours in most outdoor environments, depending on heat capacity and heat conduction of an object, condensation will be found on its surface. Repeating this process with subsequent drying 200 or more times in a laboratory environment will bring out material and design weaknesses associated with condensing humidity.

## HALT

Highly Accelerated Life Testing uses a combination step stress method to determine the margins of operation for a product and highlights weak links in a design. Stressors include cold and hot thermal stress as well as mechanical vibration stress. Table 2 shows an example of SynJet limits as determined by HALT.

## Qualification Matrix

Table 3 shows a summary of tests that were done and passed with the latest synthetic jet family of products. Besides conditions, Table 3 also indicates the sample size that was used in the test.

## Conclusion

Forced convection cooling can offer smaller and lighter weight designs while maintaining the proper thermal management needed to keep HB LEDs within their design parameters. Synthetic jet technology is an air-moving technology for forced convection cooling that is inherently reliable and rugged due to a construction that does not have moving parts in friction or require bearings or lubricants. Synthetic jet products are subjected to a rigorous qualification program to ensure the products are robust and can handle a wide application space.



**Figure 5:**  
Synthetic jet  
undergoing  
freezing rain cycle  
test



Finally, there is no exact test that can predict performance and reliability under all environmental conditions for every conceivable luminaire design. However, by simulating worst case specific environmental conditions that occur during the expected life of an HB LED light and using accelerated stress tests for anticipated failure modes one can gain confidence in applications in harsh environments. ■

**Table 2:**  
HALT operating  
and destruct limits

Summary of Operating and Destruct Limits

Stress Type	Chamber Setpoint Level
Temperature Lower Operating Limit (LOL)	-60°C
Temperature Lower Destruct Limit (LDL)	< -100°C
Temperature Upper Operating Limit (UOL)	+120°C
Temperature Upper Destruct Limit	> +130°C
Thermal Transitions (°C)	Greater than +50°C/minute
Vibration Operating Limit (OL)	45 Grms
Vibration Destruct Limit (DL)	45 Grms
Combined Operating Limit (OL)	60 Grms and 115°C to -60°C
Combined Destruct Limit (DL)	65 Grms and -60°C

**Table 3:**  
The qualification  
matrix shows a  
summary of tests  
including the  
sample size

Cat.	Test	Operating	Conditions	Samples
Storage	HAST	no	60 hours at 123°C, 96% r.h., 2 atmospheres	3
	Low Temperature	no	-40 °C	11
Operational	Accelerated Life Testing	yes	3,300 hours at 105°C	540
	Life Testing at max normal	yes	9,000 hours at 85°C, ongoing	75
	Low Temperature	yes	-40°C	87
	Humidity	yes	85°C/85% r.h., 3,250 hours	60
	Thermal Cycling	yes	-40°C - +105°C, 200x	60
Mechanical	Sine Sweeping	no	5-150 Hz, 2G 3 sweeps per axis	18
	Sine Dwelling	no	10 min each top of three peaks, 5 G	18
	Random Vibration	yes	2.2 G <sub>rms</sub> , 20 min. each axis	18
	Shock	no	Six half-sine shocks per direction, 40 G, 11 ms	18
	Bump Test	-	1,000 shocks, 25 G, 10 ms	18
Environmental	Dust	yes	12 hours IEC 60529 (IP5X)	4
	Cyclic humidity	yes	200 cycles between +50°C / >95% r.h. and +5°C / 5% r.h., such that condensation occurred	22
	Freezing Rain Cycles	yes	100 cycles between +25°C / 95% r.h. and -10°C / u.c.r.h.	21

**References:**

- [1] Strategies Unlimited, "High-Brightness LED Market Review and Forecast 2010", pp. 78- 83, June 2010
- [2] Lasance, Clemens J. M., Aarts, Ronald M., "Synthetic Jet Cooling Part I: Overview of Heat Transfer and Acoustics", 24th IEEE SEMI-THERM Symposium, 2008, pp. 20-25, 2008
- [3] Mahalingam, R., N. Rumigny, A. Glezer, "Thermal Management Using Synthetic Jet Ejectors", IEEE Trans on Components and Packaging Technologies, Vol. 27, No. 3, pp. 439-444, 2004
- [4] Mahalingam, R., A. Glezer, "Design and Thermal Characteristics of a Synthetic Jet Ejector Heat Sink", Journal of Electronic Packaging, Vol. 127, pp. 172-177, 2005
- [5] Mahalingam, R., S. Heffington, L. Jones, R. Williams, "synthetic jets for forced air cooling of electronics", Electronics Cooling, Vol. 13, No. 2, 2007
- [6] Tian, Xijin, "Cooling Fan Reliability: Failure Criteria, Accelerated Life Testing, Modeling and Qualification", Annual Reliability and Maintainability Symposium, 2006, pp. 380-384, 2006
- [7] Noska, B., Che Cheung Jin, H. Mahalingam, R., "Enabling new LED designs through advanced cooling technology", Semiconductor Thermal Measurement and Management Symposium, 2010, SEMI-THERM 2010. 26th Annual IEEE, pp. 305-310
- [8] [http://apps1.eere.energy.gov/buildings/publications/pdfs/ssl/outdoor\\_area\\_lighting.pdf](http://apps1.eere.energy.gov/buildings/publications/pdfs/ssl/outdoor_area_lighting.pdf)
- [9] Schwickert, M. M., IEEE Transactions on Reliability, pp. 449-482, Volume 59, Number 3, September 2010

# Thermal Management of LED Lamps

A.Motoya, M. Kai, Y. Manabe, and S.Shida from Panasonic Corporation Lighting Company show what measures can be taken to fulfill the requirements for LED replacement lamps, and which of these measures have the greatest impact.

Because of global environmental pressure, people all over the world have started replacing conventional types of lighting with higher efficiency light sources. In Australia and the EU, governments announced that the sales of traditional incandescent lamps would be prohibited starting in 2010.

Conventional light sources (fluorescent lamps, halogen lamps) have improved over the past 30 years. On the other hand, white LED (Light Emitting Diodes) has improved rapidly over the past 10 years as shown in Figure 1.

Because LED lamps save energy and extend the light's lifetime, they are likely to replace other technologies such as incandescent and fluorescent lamps in signal solid state lighting, and vehicle headlights. Many LED lamps are developed by light source industries, and the use of LED lamps has been increasing exponentially over the last few years. If it reaches the size of GLS it will have spread remarkably far all over the world.

The structure of the LED lamp is explained in the following procedure: The LED chip is mounted on the board and then it is sealed with the resin that is mixed with phosphor. This is called an LED module. When electric power is loaded, approximately 30% of input power is converted to white light and 70% is converted to heat [1].

Excess heat directly affects both short-term and long-term LED performance. The short-term effect is luminous efficacy and the long-term effect is accelerated lumen depreciation and thus shortened useful time.

Three things affect the  $T_j$  (junction temperature) of an LED: drive current, thermal system, and ambient temperature. In general, the higher the drive current, the greater is the generated heat, as shown in Figure 2. Heat must be removed from the LED in order to maintain expected luminous efficacy and lifetime.

Therefore, thermal management of the LED is a crucial area of research and development.

In this paper, to investigate the proper thermal management structure for LED lamps, the following three steps have been reported by means of a CFD model.

First, the design concept was made according to the desired lamp specification targets. Second, the bottle neck elements of heat dissipation were determined, and the thermal phenomena analysed. Third the design parameters of the bottle neck elements were calculated.

## Thermal Management of the Retrofit LED Lamp

The starting point for the analysis and design simulation is a set of functional relations for the thermal phenomena and design parameter. The three phenomena of heat transference are conduction, radiation, and convection. The relation between the three phenomena and the design parameter are shown in Table 1. When the design parameter is changed, each phenomenon changes accordingly.

**Figure 1 (left):** Light source history: luminous efficacy

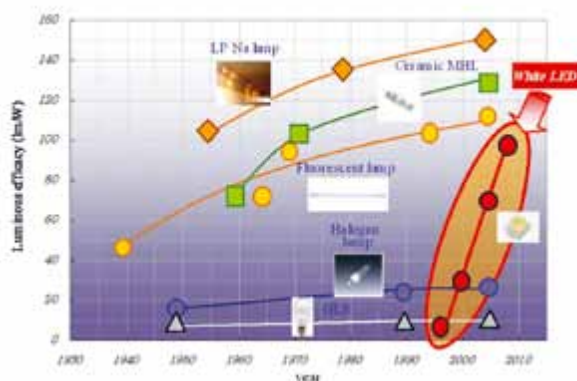

**Figure 2 (right):** Relation of light source luminous efficacy and power

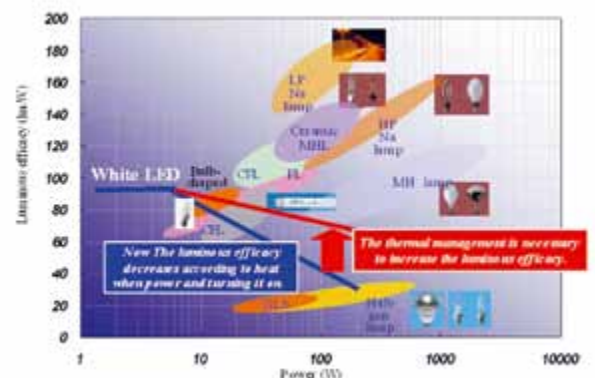

# 2<sup>ND</sup> ANNUAL

 **OLEDINSIDER**

# OLED LIGHTING DESIGN SUMMIT

THE WORLD'S LEADING OLED LIGHTING EVENT



**JUNE 22-23 2011, REGENTS PARK MARRIOTT HOTEL, LONDON, UK**

## Access new markets and attract new customers by capitalising on new OLED applications and technology

- **APPLICATIONS:** Discover the most lucrative and innovative applications for OLED Lighting and the steps your business needs to take to profit from them
- **LIGHTING DESIGNERS:** Hear from over 30 of Europe's leading lighting design companies on the type & specification of OLED products you need to manufacture to win their business
- **TECHNOLOGY:** Evaluate the very latest OLED Lighting technology breakthroughs that will supercharge your design capabilities
- **GOVERNMENT INCENTIVES:** How you can utilise government tax breaks & incentives to reduce costs and win new business
- **CAPTURE NEW LIGHTING MARKETS:** Understand the products, applications and partnerships you need to win new markets with OLED lighting technology

**THE HIGHEST LEVEL OF SPEAKERS SHARING THEIR KNOWLEDGE AND EXPERIENCE WITH YOU!**

**OSRAM**  
Opto Semiconductors

 **Holst Centre**  
Established by STC and STG

**UNIVERSAL DISPLAY CORPORATION™**

**BDP.**

Elizabeth Clark  
Product Design

benwirth licht

Technology Strategy Board  
Driving Innovation

 **OLED**  
100.eu

**AcuityBrands™**  
Lighting

**THORN**

**TRILUX**  
NEW LIGHT

**ARUP**

**novava**  
Novalia - Interactive print

**OLED**  
ASSOCIATION

**The best speakers... and the most incredible networking opportunities**

### Are you serious about OLED?

**6 excellent reasons why you must attend this event!**

- ★ **Over 30 leading lighting and product designers already confirmed**
- ★ **Over 200 lighting industry experts set to attend**
- ★ **Top case studies from European and international OLED lighting**
- ★ **Focused OLED exhibition**
- ★ **Over 12 hours of networking and business building opportunities**
- ★ **Panel sessions, discussion groups, key note speakers**

*The world's first and only event focused exclusively on OLED lighting technology and applications*

Supporting Associations:

**OLED**  
ASSOCIATION

**ILA**  
The Lighting Association

**IALD**

**ILP**

**FREE INTERVIEWS,  
WHITEPAPERS,  
PRESENTATIONS  
AND MORE**

Visit [www.oledinsider.com/lighting](http://www.oledinsider.com/lighting)

**Table 1:**  
Approach of thermal management and thermal phenomena

	Surface area	Sectional area	Thermal conductivity	Thermal transivity	Emissivity
Conduction		○	○		
Radiation	○				○
Convection	○			○	

Conduction is the transmission of heat across a solid by way of kinetic energy between atoms. Thermal flux within and between materials is proportional to the temperature gradient and the cross-sectional area of the conductive path.

Convection is the transfer of heat by flow in a liquid or gas. Convection amount of thermal energy is proportional to the surface area and the temperature gradient between the surface and the fluid.

Radiation is emitted energy by electromagnetic waves from the surface of a solid. Radiation energy is proportional to the surface area and emissivity of the object's surface.

Therefore, it is necessary to design parameters according to thermal phenomena for improving heat dissipation.

Consequently, analyzing the phenomena is very important for designing parameters.

### Design Concept of a Typical Retrofit LED Lamp

At the start of creating a design concept, the desired targets of the lamp specification should be clarified. In this article, they are as follows:

- Lumen output: >560 lm
- Input power: <7.6 W (i.e. lamp efficacy: >75 lm/W )
- Weight : <100 g
- Sophisticated lamp figure

The lumen output mentioned above is almost equivalent to a 40 watt incandescent lamp.

The more the  $T_j$  is increased, the more the luminous efficacy of the LED chip is decreased. To achieve the target of

75 lm/W luminous efficacy it is very important to control the  $T_j$  appropriately in order to avoid excess heat. In short, thermal management is the key approach to realizing the target specification.

Before evaluating the characteristics of a lamp by means of a real prototype, it is very useful to use a modelling tool for a feasibility study. Figure 3 shows the CFD mesh model used in this case. The LED chip is mounted on the substrate and the substrate is on the module plate. The module plate is connected to the edge of the case. The electric circuit as an LED driver is included in the case. The LED chip plays the role of the main heat source in the CFD model.

Based on this model, a thermal network structure is interpreted as shown in Figure 4. By putting the temperature result, which is calculated in the CFD model, into the thermal network, the values of thermal resistance are conducted.

A comparison of each value would point out the branch which should be improved for proper heat transfer. In Figure 3, the thermal energy from the LED chip is mainly transferred to the substrate, the module plate, and the case. Finally, it is discharged into the air from the surface of the case. First of all one has to find the bottleneck element of thermal transfer in this thermal network. The efficiency of power conversion on the electric circuit is 86% in this case.

As a result, when 7.6 watts, as the input power specified, is loaded into the LED lamp, the 6.5 W that are distributed would be consumed by the LED chip. Then 68% of the distributed power is converted to thermal energy (i.e 32% of it is emitted as light).

It means 4.51 W is dissipated as the thermal loss on the LED chip, which, in other words, is the heat source of the CFD model. The relation among  $T_j$ ,  $T_a$  (ambient temperature: 25°C),  $Q$  (thermal energy: 4.51 W) and  $R_t$  (total thermal resistance between  $T_j$  and  $T_a$ ) is shown in equation (EQ 1).  $T_j$  is 100°C, which is set with respect to the LED chip quality assurance.

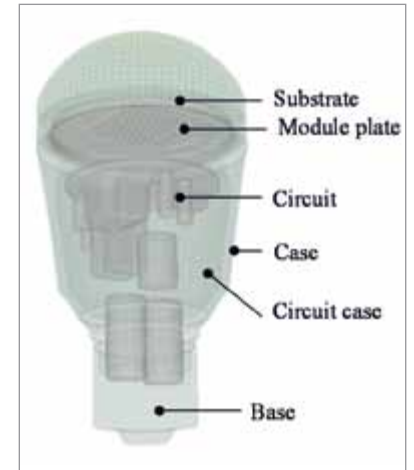

Figure 3: Modelling the LED lamp

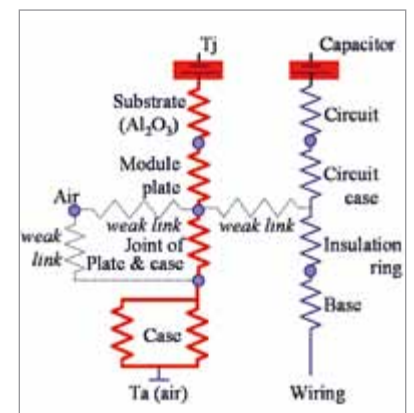

Figure 4: Heat circuit of an LED lamp

It Using equation (EQ 1) with the value of  $T_j$ ,  $T_a$ , and  $Q$  mentioned above,  $R_t$  was calculated, as  $R_t \geq 16.63$  K/W. This value  $R_t \geq 16.63$  is the boundary line for achieving the target specification of this lamp. Equation (EQ 2) shows the detailed structure of  $R_t$ .  $R_a$ ,  $R_b$ , and  $R_d$  are the thermal resistance values of substrate and module plate each,  $R_{air}$  is the one of the gap between module plate and case,  $R_d$  is the one of the region between the surface of the case and ambient. For solving these equations (EQ 1, EQ 2),  $R_a$ ,  $R_b$ ,  $R_{air}$  and  $R_d$  were derived by CFD model of a certain initial prototype design.

These values were estimated as  $R_a: 2.08, R_b: 0.04, R_{air}: 2.75$  and  $R_d: 16.0$  K/W.

At this point, when considering thermal transfer mechanism on each of the thermal resistance elements,  $R_a, R_b$  and  $R_{air}$  are mainly dependent upon material properties (i.e. thermal conductivity of solid bulk). That is, unless it is adapted to change the material, it is generally difficult to change the thermal resistance,  $R_a, R_b$  and  $R_{air}$ .

On the other hand,  $R_d$  is dependent on not only the material properties of the case but also any surface condition of it because  $R_d$  is defined on the boundary between solid and gas. Furthermore, the ratio of  $R_d$  is the largest value among other ones in the equation (EQ 2), which means that controlling the value of  $R_d$  would be the most effective way to manage the value of  $R_t$  without changing the material of the case. Then, suppose  $R_a, R_b$  and  $R_{air}$  to be fixed values as mentioned above.  $R_d$  was calculated as  $11.76 \geq R_d$  using the equation (EQ 3). Thus if  $R_d$  is less than  $11.76$  K/W, the  $T_j$  can be kept below  $100^\circ\text{C}$  which is the maximum temperature allowed. The critical value of  $R_d = 11.76$  was determined as the target value here. What is needed is to decrease  $R_d$  from  $16.0$  of the initial prototype case to  $11.76$  as the target value.

$$T_j - T_a \geq Q \times R_t$$

$$75 \geq 4.51 \times R_t \tag{EQ 1}$$

$$16.63 \geq R_t$$

$$R_t = R_a + R_b + R_{air} + R_d \tag{EQ 2}$$

$$16.63 \geq 4.87 + R_d$$

$$11.76 \geq R_d \tag{EQ 3}$$

As the second step, the thermal management performance of the lamp case was the most important element for controlling the value of  $T_j$ . Thermal resistance of the case,  $R_d$ , depends on enveloped case volume [2]. The relation between the enveloped case volume and thermal resistance is calculated as shown in Figure 5. When the enveloped case volume is  $42,500 \text{ mm}^3$ , thermal resistance reaches  $11.70 \text{ K/W}$ . However, this volume ( $42,500 \text{ mm}^3$ ) is not permitted because this size is too big compared to the equivalent incandescent lamp which has been used up until now. Therefore, a different approach is needed for decreasing  $R_d$  as the third step.

In fact, as shown in Figure 4, it is found that  $R_d$  consists of two elements. These are: convective elements ( $R_c$ ) and radiative elements ( $R_r$ ).  $R_c$  and  $R_r$  are conducted from the equation (EQ 4 - EQ 6). The value of  $hc$  is the convection

efficiency solutions  
by direct bond copper

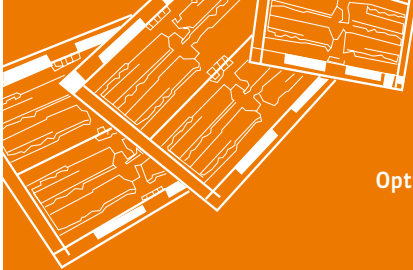
High thermal conductivity  
Excellent for chip on board  
Optimized heat spreading  
DBC SUBSTRATE



Highly integrated cooler  
Outstanding thermal performance  
Customized design  
DBC COOLER

curamik electronics GmbH  
Am Stadtwald 2  
D-92676 Eschenbach  
Phone +49 9645 9222 0  
info@curamik.com  
www.curamik.com

A division of  
 **ROGERS**  
CORPORATION

**Figure 5:**  
Relation between thermal resistance and enveloping volume

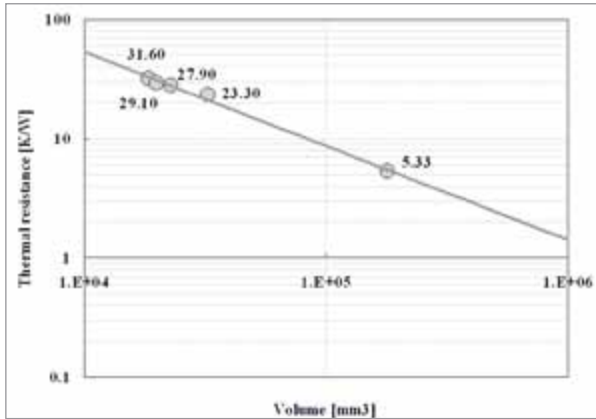

**Figure 6:**  
The Thermal resistance ratio of the thermal process (in case of A: 6000 mm² & ε: 0.2)

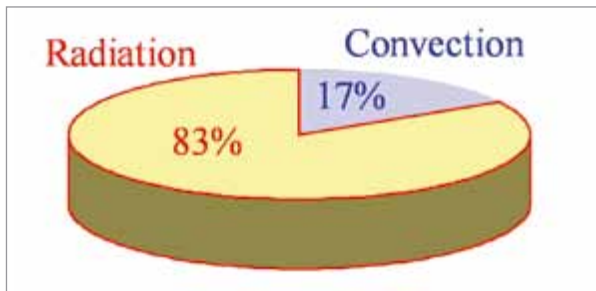

**Figure 7:**  
Relation between thermal resistance and emissivity

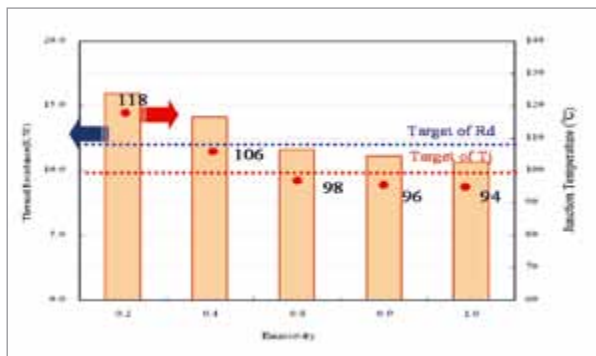

**Figure 8:**  
LED product was designed with proper thermal management

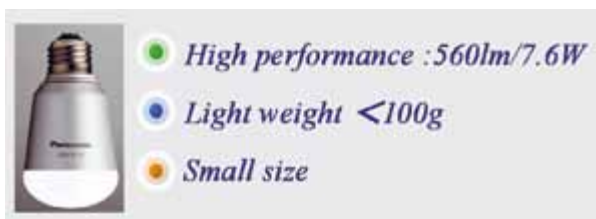

coefficient, which is similar to the heat transfer theory.  $h_r$  is the radiation coefficients derived from Plank's law. Then,  $R_c$  and  $R_r$  are calculated using these equations (EQ 4 - EQ 6).

Whereby  $h_c$ : convection coefficient [W/m²K] | C: 0.55 | L: Length |  $T_\infty$ : T air |  $T_w$ : T surface of heat sink |  $h_r$ : radiation coefficient [W/m²K] | ε: emissivity | A: surface area

The surface area (A) is set to 6,000 mm² as a typical and desirable value. Emissivity of the case surface is 0.2 (pure aluminium). The results are shown in Figure 6. The weight of  $R_r$  accounted for 83% of total thermal resistance. From these results, it was confirmed as the effective approach to improve the radiative performance of lamp case surface for finally decreasing  $R_\theta$ .

As stated above, the effect on decreasing  $R_d$  is estimated when changing the lamp case surface characteristics. Figure 7 shows  $R_\theta$  dependence on the emissivity of the lamp case surface. The emissivity is changed from 0.2 to 1.0. As the emissivity increases,  $R_d$  decreases. In addition, Figure 7 also shows  $T_j$  which depends on the emissivity. According to Figure 7, in case that  $R_\theta$  and  $T_j$  are made to satisfy the target value, i.e.  $R_\theta$ : 11.76 k/W and  $T_j$ : 100°C, it is found that emissivity should be more than 0.8. Then, authors adopted "anodizing on the surface" to increase the emissivity from 0.2 to 0.8 and make an accurate prototype as the final step. As a result of temperature measurement on this prototype, it is confirmed  $T_j$  reaches 98°C on the emissivity 0.8, which means within 100°C.

Along with the mentioned steps, the very small size and more efficient retrofit LED lamp was successfully developed as shown in Figure 8.

### Next Approach of Thermal Management for LED Lamps

The investigation on a proper thermal management structure for retrofit LED lamps, followed the four steps mentioned above based on the CFD model results.

This modelling will be also applicable for developing other LED products. LED products are likely to replace high-power lamps such as ceramic-metal-halide lamps in future. The more electric power is loaded to get high-brightness, the more the heat converted is increased.

Therefore thermal management will become more and more important for future LED products. ■

$$R_d = \left( \frac{1}{\frac{1}{R_c} + \frac{1}{R_r}} \right) \tag{EQ 4}$$

$$R_c = \left( \frac{1}{A \times hc} \right) \tag{EQ 5}$$

$$R_r = \left( \frac{1}{A \times hr} \right)$$

$$h_c = 2.51C \left( \frac{T_w - T_\infty}{L} \right)^{0.25}$$

$$h_r = \varepsilon \times 5.65 \times 10^{-8} (T_w^2 + T_\infty^2) (T_w + T_\infty)$$

### References:

[1] Lighting Hand Book, pp. 102- 146 (2003)  
[2] Naoki Kunimine, Heat design complete introduction for electronics, pp.170 (1997) (in Japanese)

# EUROPE'S LEADING EVENT

FOR LED AND SOLID STATE LIGHTING

## euroLED™ 2011

Taking place on 8th and 9th June 2011 at the Jaguar Exhibition Hall, the Ricoh Arena, Coventry, UK.

Don't miss out on your chance to be a part of Europe's leading Solid State Lighting industry event, featuring a packed Conference programme, Gala Dinner and Exhibition.

Registration is now open for:

- Sponsorship opportunities
- Exhibition stands
- Conference passes
- Exhibitor passes
- Gala Dinner tickets

Sponsorship opportunities are available across the event programme, so register your interest now by visiting [www.euroLED.org.uk](http://www.euroLED.org.uk), email [info@euroled.org.uk](mailto:info@euroled.org.uk) or call Stephy Kuriakose on +44 (0)121 250 3515 or Stacey Ludlow on +44 (0)1372 802 052



[www.euroled.org.uk](http://www.euroled.org.uk) | [info@euroled.org.uk](mailto:info@euroled.org.uk) | +44 (0)121 250 3515 or +44 (0)1372 802 052 | Follow us: [twitter.com/euroled](https://twitter.com/euroled)

# NEPCON

MALAYSIA 2011



Be Here. Be Seen.  
**Be Connected.**

14 – 16 June 2011  
Penang International Sports Arena (PISA)  
[www.nepcon.com.my](http://www.nepcon.com.my) • [nepcon@reedexpo.com.my](mailto:nepcon@reedexpo.com.my)

NEPCON Malaysia is the single largest sourcing ground for PCB/SMT, components, testing and measurement, semiconductor, LED and support services sectors in Malaysia.

Visit [www.nepcon.com.my](http://www.nepcon.com.my) to pre-register now!

Organised by  Reed Exhibitions®

# HB-LED Alert Device with Intense Light Output

Jerry Vereen, Principal Engineer of Egret Technologies shows how LED technology opens fields for new applications and can make life easier. He gives insights in challenges and future perspectives.

The deaf community is using standard Videophones and sign-language to communicate. Video Relay Services are also available to enable a deaf person to communicate with a hearing person by way of a sign-language interpreter at a call center. This article discusses how Egret Technologies used LED technology in the design of a product to provide an intense light output to alert the deaf person of an incoming Videophone call.

## Problem

Standard off-the-shelf Videophones operate assuming the person can hear the ring signal and answer the call. However, calls are often missed for the deaf or hard of hearing person. An attempt to solve this problem without modifying the Videophone hardware was made by simply flashing the LCD screen of the Videophone on and off. Needless to say that the amount of light from the screen was just not sufficient to call attention to a person in an adjacent room or with their back turned. Egret Technologies was given the task to provide a cost effective and innovative solution.

## Solution

The Alert Device (Flasher) provides a high output light “pulse” similar to a camera flash to call attention to the deaf person that a call is coming in. The Flasher is a separate device that sits near the Videophone and is attached to the Videophone. In addition to providing an intense light

output, the cadence of the “flash” can be controlled by the Videophone to allow different on and off times and patterns based on received caller ID. Similar to a caller ID on a phone, the pattern of light pulses can be used to identify the caller at a distance from the Videophone. The Videophone and Flasher solution is shown in Figure 1.



Figure 1: Videophone and flasher

## Ring Strobe Signal

When a call is received at the Videophone it identifies the caller and drives a strobe signal to the Flasher. The Flasher receives this signal and generates an intense flash of light to alert the deaf person of an incoming call. The duty cycle of the Ring Strobe Signal determines the on time duration and the off time duration according to the caller ID pattern.

## Product Requirements

The required size of the product needed to be about the size of a small PC speaker. The customer required front, back, and side visibility of light. The design also needed to have a firm and sturdy feel and be heavy enough so that attached cables would not pull the unit off a countertop or desktop. The required unit cost also had to be very low (less than \$20 (€14 EUR) to the end user).

The light intensity requirement was not directly specified, however, the customer required the need for a

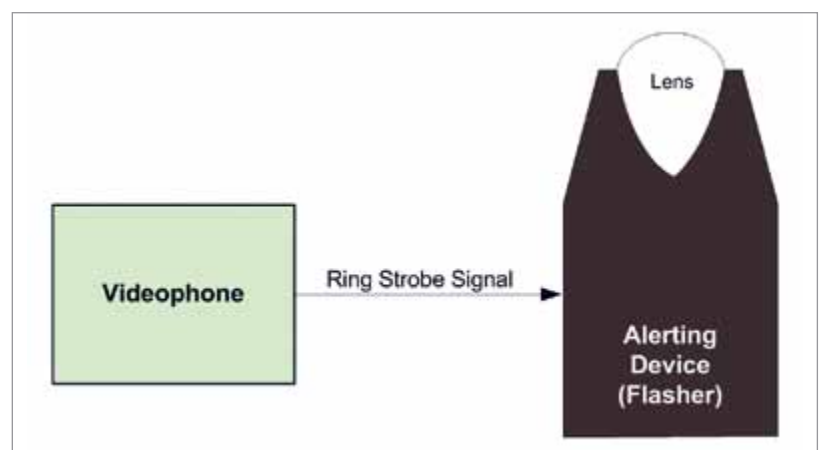

Figure 2: Videophone sends ring strobe to flasher





[www.ledlightforyou.com](http://www.ledlightforyou.com)

## How may we help you?

Certified Partners from all over the world are available in the LED Light for you network. They will be happy to support you with system integration and optical, thermal and electronic solutions. Look and see!

The network for LED lighting technology.

**LED**  **Light for you**  
powered by OSRAM

strong flash similar to a camera flash, but with the option to use longer on time durations. Customer approval was obtained before committing to hardware, by Egret Technologies performing a live demonstration using an LED Driver Evaluation Kit, LED Module, and sample lens at the customer facility.

### The Light Source - Competing Technology

Various lighting technologies were examined prior to the onset of the project. The primary contenders were the Xenon Flash Tubes and High Brightness White LEDs.

#### Xenon Flash Tubes:

- Flash “on” time limited to short bursts
- Circuitry more complex
- Very high voltages required to drive the Xenon bulb complicating the UL approval process
- Higher part cost than LEDs
- Higher manufacturing assembly costs due to package type
- Shorter bulb life

#### High Brightness LEDs:

- Supports longer “on” times
- Operates from “safe” low voltages
- Surface mount package can be placed by machine reducing manufacturing assembly and labor cost
- Lower part cost
- Longer life
- Off-the-shelf LED driver chips available

The initial demonstration at the customer’s facility was done with a single LED module. At that point the customer requested that a second LED module be added.

### Core Design Attributes

The heart of the design consists of a Camera Flash Boost Converter IC and two High Brightness LED modules. The Boost Converter is configured to operate in strobe mode for this application. In this mode, the Boost Converter switches continuously to supply maximum current for the LEDs, but for a limited time. The current through the LEDs is regulated by the Boost Converter and set by an external resistor. The time duration of the strobe signal (Strobe~) controls the LED on time. The Boost Converter consists of a gated oscillator, a 24 V boost circuit, and an LED current-regulation circuit. The Boost Converter operates from a 2.6 V to 5.5 V input range. For this application, the input supply was sourced from a wall-mounted AC/DC power supply that outputs +5 VDC at 1A.

With two LED modules there is enough light output to alert the person, even if they are not close to the Flasher. Each LED module has three LEDs which are connected in parallel in the design. The

Modules are then connected in series. Read further to understand this design decision.

### Design Considerations

LED: Selection of the LED required obtaining samples and running some tests in the lab. Based on these tests a 3-LED High Brightness LED Module was selected that has a wide dispersion angle of 120°. This provides the desired distribution of light across the room. To approach 360 degrees of light from the Flasher, two LED modules were used (one on each side of the PCB). This approach allows the device to be placed almost anywhere in the room, even against a wall. To that end the PCB and Lens were “arched” to extend the height of the LEDs above the black plastic housing and provide side light. See Figure 4.

LED Configuration: The boost converter’s 24 V output voltage is high enough to drive a string of LEDs in series. For this design a combination of series and parallel is used.

Note that parallel LEDs may exhibit slight variation in forward current from LED to LED resulting in differences in brightness. This affect is minimal if the LEDs are on the same substrate as is the case for this application.

**Figure 3:**  
Typical Xenon flash tube (left) and CREE CLP6B-WKW-CD0E0453 LED package (right)



Although the xenon flash tube does provide an intense and pure white light output, the LED solution was better especially in terms of lower design complexity and lower cost. Finally, the ability to have longer on times was a plus.

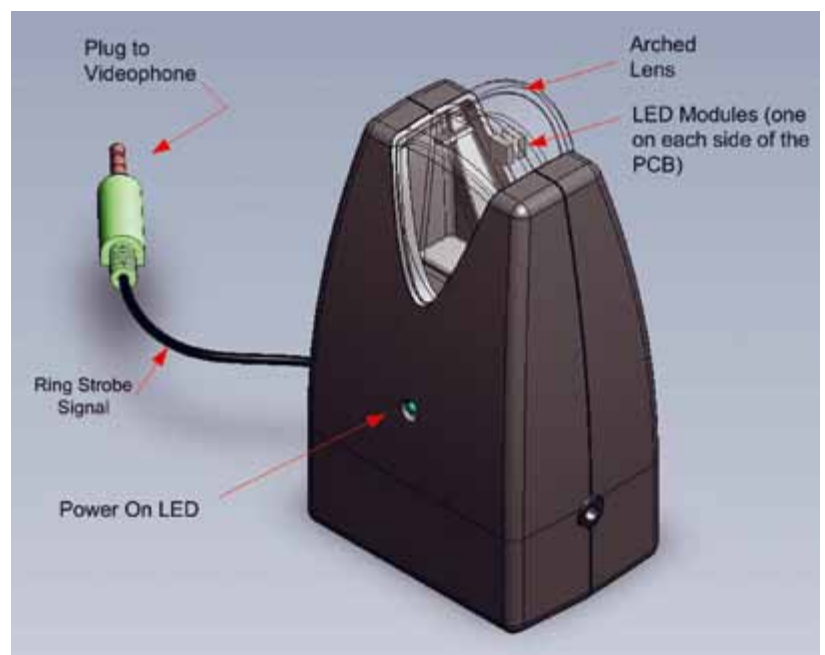

**Figure 4:** LED module location

Given the 24 V output of the Boost Converter and the worst case  $V_F = 4.4$  V of an individual LED, the following scenarios fall out:

**6 LEDs in series:**

$6 \times 4.4$  V = 26.4 V (voltage drop too high for Boost Converter)

**2 LEDs in series, 3 in parallel:**

$2 \times 4.4$  V = 8.8 V

The 2<sup>nd</sup> scenario is a reasonable compromise between a series and parallel configuration and was the one Egret Technologies chose for this design. The LED Modules are then placed in series to ensure that both Modules are driven at the same current level, while the individual LEDs within each Module are in parallel. See Figure 5.

**LED Brightness:** LED Brightness is determined by forward current. The LED Module is specified for a continuous forward current of each LED in the Module at 50 mA. This was the current level that was chosen and configured to be driven by the Boost Converter. Maximum peak forward LED current is 100 mA for each LED, allowing for an additional 50 mA of current margin. Maintaining LED current control was critical to the design and this was handled by the Boost Converter as follows.

The typical forward drop of an individual LED is 3.8 V at 50 mA. The strobe current is then set by the resistor  $R_{STB}$ . From the Boost Converter's data sheet,  $R_{STB} = 600 / I_{LED}$ . Since there are 3 LEDs in parallel the current is evenly divided for this estimate.

$I_{LED} = 3 \times 50$  mA = 150 mA,  
therefore desired  $I_{LED} = 150$  mA

Now calculating  $R_{STB}$ :  
 $R_{STB} = 600 / 150$  mA = 4 k $\Omega$

**Boost Converter:** The Boost Converter is actually a switching regulator designed to drive LEDs, therefore careful attention to the selection of inductor, input capacitor, and output capacitor is prudent, as well as in

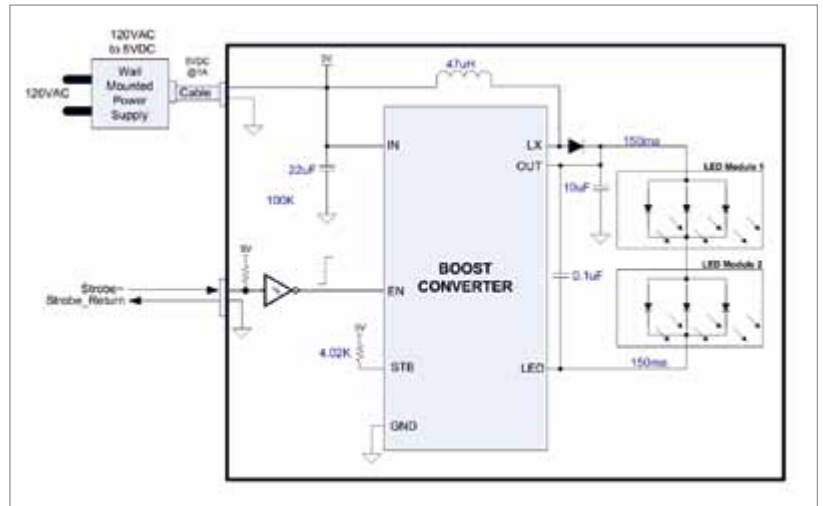
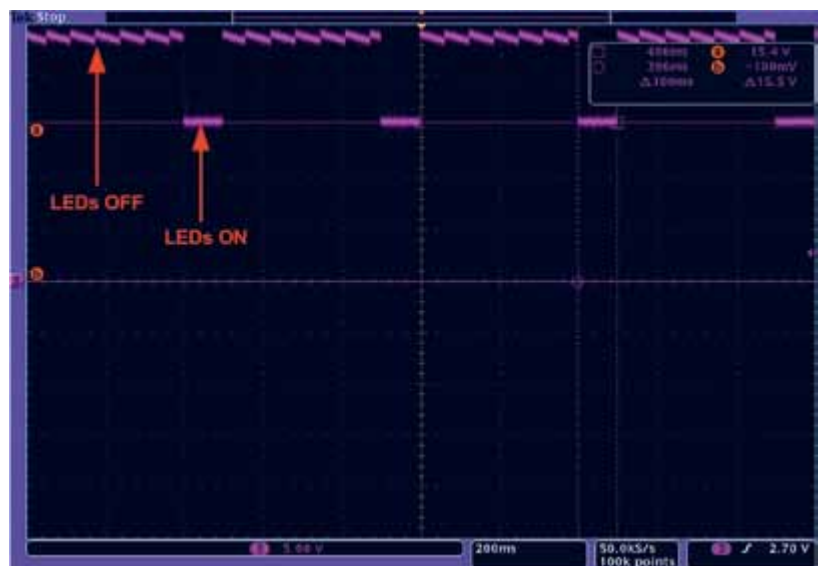

**Figure 5: Flasher circuit block diagram**

providing a clean feedback signal with little noise, as is true with any switching regulator design. The Boost Converter controls LED brightness by regulating the current through the LEDs to a selectable level controlled by an external resistor. The current into the LEDs is regulated to 1000 times the current set by the STB pin resistor,  $R_{STB}$ . When the EN pin is low the converter is in precharge mode and the converter switches continuously until the output capacitor is charged to 24 V. Once the OUT feedback pin reaches 24 V, the converter does not switch again until OUT falls below 23.5 V. This results in 500 mV ripple on the output. The LED pin is high impedance in the precharge state and

the external LEDs are off. Conversely, when the enable pin is high the LED driver turns on and the LEDs illuminate. Figure 6 depicts the 24 V precharge state (LEDs off) and the LED on state where  $\sim 7.6$  V is dropped across the output (due to 2 series LED's).

**Schmitt Trigger Buffer:** The Strobe signal from the Videophone was treated with additional care as the signal is being driven over a cable several feet. Being a TTL level signal and the fact that capacitance in the cable would slow the edges, an input buffer was added to the design to clean up the signal, rather than connecting directly to the Boost Converter's enable pin. The buffer



**Figure 6: Scope plot of boost converter's LED drive**



Figure 7: Mechanical design

selected has a schmitt trigger input stage which adds hysteresis to the switching region. The buffer also protects the boost regulator from external voltage transients that might otherwise damage the boost regulator. Finally, a pull-up resistor was added to the input of the buffer to ensure that the enable signal is deactivated when there is no cable connected from the answering device to the Flasher, while power is applied to the Flasher.

**Mechanics:** The enclosure is a molded plastic housing (ABS UL94-V0) customized for appearance and application. The Lens is polycarbonate UL94-V0 and tinted white with 50% translucency. A weight is placed inside the bottom of the unit to provide stability.

### Application Hints

**LED On Time:** There was no limitation built into the Flasher hardware design to prevent excessively long LED on times. At the same time, however, the brightness of the LEDs was critical to user satisfaction. Since current is pulsed to the LED, the highest brightness is obtained by providing a short duration flash. If the LED is left on for a “long” time, the power consumption is high and the parts can build up heat. Although no damage can occur due to this scenario, it was recommended to use LED On times shorter than 200 ms.

### LED On Time Specification (High Brightness Flash).

Condition:

Strobe control line from the Videophone in the low state,  
LED On Time Spec:  
30 ms (typical), 200 ms (maximum)

- “On” times shorter than 30 ms can be used to convey caller ID info
- “On” times in the 30 ms to 100ms range provide a high brightness output

### Cadence Ideas for Caller ID

Caller ID can be used to provide unique per caller (or per caller group) flash sequences, controlled by the pulse width and timing of the strobe control signal.

The following methods illustrate the concept:

- Combine a number of successive high brightness flashes with different off times between groups of flashes
  - ON, Long OFF, ON, Long OFF, etc
  - ON, short OFF, ON, Long OFF, etc
  - ON, short OFF, ON, short OFF, ON, Long OFF, etc
- Combine “low” level LED flashes with high level LED flashes, e.g. A 400 microsecond LED On pulse is still visible and these low light “blips” could be interspersed with high brightness flashes to convey ID information. The Long Off time could contain a number of these low light pulses.

### Conclusions

Applications for High Brightness LEDs are evolving into many areas and uses. To ensure that the LEDs truly provide years of operation in an application, the electronics that drive the LEDs must be designed carefully and with plenty of margin built in. The approach that Egret Technologies took was to design from a systems perspective. After all, it does not matter what fails, the life of the LED is dependent on the life of the supporting electronics as well. ■



## New ILD 4001 step-down LED controller – perfect fit for various lamps and general lighting systems



This brand new product offers you maximum design flexibility.

- Scalable output stage with external MOSFET up to 5A
- Choice of dimming concepts – PWM or analog voltage
- Supply voltage for 12V, 24V and 40V applications
- Overcurrent, overvoltage and thermal protection

To learn more about the LED driver portfolio for General Lighting, please visit

[www.infineon.com/lowcostleddrivers](http://www.infineon.com/lowcostleddrivers)

# Lighting Fair 2011

## LED/OLED Lighting Fair 2011

September **21**(Wed) - **23**(Fri), 2011 | **coex**, Seoul, Korea

**Organized by** Korea Institute of Lighting Technology[KILT]  
The Korean Institute of Illuminating and Electrical Installation Engineers[KIEE]

**Managed by** Exporum

### Exhibit Profile

- Lighting Application
- Lighting Products
- Lighting Design
- Lighting Systems and Services
- LED/OLED Lighting Devices
- LED Components and Material
- LED Manufacturing and Testing Equipment

**Exhibition Scale** 200 Exhibitors from 10 Countries  
30,000 Visitors

**Application Deadline** Aug. 31(Wed), 2011

### Contact Us

**LIGHTING FAIR 2011 Secretariat** Tel. +82-2-6000-6676, 2051-3322 Fax. +82-2-2051-3326 E-mail. Lighting@lightingfair.co.kr

### Concurrent Events

- Awards Ceremony of Lighting Fair 2011
- International Lighting Technology Conference
- Business matching Service



# Imprint

LED professional Review (LpR)  
ISSN 1993-890X

## Publisher

Luger Research e.U.

Institute for Innovation & Technology  
dep. LED professional  
Faerbergasse 15, Haus Rot  
A 6850 Dornbirn, Austria / Europe

phone +43 5572 394 489  
fax +43 5572 394 489 90  
editors@led-professional.com  
www.led-professional.com

## Publishing Editors

Siegfried Luger  
Arno Grabher-Meyer

phone +43 5572 394 489  
phone +43 5572 394 489-18  
editors@led-professional.com

## Int. Account Manager

Theresa Koenig

phone +43 5572 394 489-20  
theresa.koenig@led-professional.com

## Front-page picture

Image: Arno Grabher-Meyer, LED professional, SoLED Solar Street Light  
Artwork: Thomas Klobassa, ©LED professional 2011

## Copyrights – Luger Research e.U.

The editors make every reasonable effort to verify the information published, but Luger Research e.U. assumes no responsibility for the validity of any manufacturers, non profit organisations or individuals claims or statements. Luger Research e.U. does not assume and hereby disclaims any liability to any person for any loss or damage caused by errors or omissions in the material contained herein, regardless of whether such errors result from negligence, accident or any other cause whatsoever. You may not copy, reproduce, republish, download, post, broadcast, transmit, make available to the public, or otherwise use LED professional Review (LpR) content without prior written consent from Luger Research e.U. – Institute for Innovation & Technology, Austria. ■



## LED professional Review (LpR) - Annual Subscriptions

### LpR Digital Magazine

- 6 issues
- pdf download
- high resolution pictures and graphs
- printable
- commercial use
- access to all previous issues
- Euro 78.80

<http://www.led-professional.com/subscription>

### LpR Printed Magazine

- 6 issues
- Euro 158.40

Next LpR Issue - July/Aug 2011  
LEDs, Color Conversion, Thermal

# LED professional

## SYMPOSIUM +EXPO

# LpS 2011

## LED Lighting Technologies

International Winning Approaches

27-29 SEPTEMBER 2011 | BREGENZ | AUSTRIA

info@lps2011.com | www.lps2011.com

EARLY BIRD BONUS  
SIGN UP NOW!  
[www.lps2011.com](http://www.lps2011.com)

TRIDONIC

▼ Inspiring our world

OSRAM

Opto Semiconductors

e-lumix

LED Technologie GmbH



## Transforming Light

LUXEON LEDs are changing the way we light the spaces we live, shop and play in. With unparalleled efficiency, quality, and reliability, LUXEON LEDs are a simple way to transform lighting and improve the well being of our environment.

Whether you're lighting a restaurant, roadway or architectural masterpiece, you can count on LUXEON to deliver long life, high-quality white light while reducing energy consumption.

To learn how LUXEON can help you transform lighting, call our partner, Future Lighting Solutions, at +1-888-589-3662, or visit [www.philipslumileds.com/transform](http://www.philipslumileds.com/transform)

L U X E  N<sup>®</sup>

**PHILIPS**  
LUMILEDS

## CREE® XLAMP® MT-G LEDs

Up to 560 lm (92 LPW) at 6W, 3000K, 85°C | Easily fits into MR-16 form factor with optic  
Light output to match 35W-50W halogen | First LED binned at high temperature  
Incandescent-like color consistency | Single-point-source of light



# “GOOD ENOUGH” IS NOT GOOD ENOUGH FOR US.

## LED REVOLUTIONARY

**Mark McClear**

Global Applications Engineering at Cree

Why settle for “Good Enough”? We reject the notion that one size fits all. We believe in the right LED for each application. We are designing Lighting-Class LEDs optimized for your application and specific to your needs.

The new Cree XLamp MT-G is a revolutionary LED, created to enable LED light in challenging, small-form-factor, 35W to 50W, halogen retrofit designs. Whether you are engineering indoor, outdoor or portable lighting, Cree has the application-optimized LED for your design and application support for you.

*Request a sample and find a Cree Solutions Provider or authorized distributor at [MTG.cree.com](http://MTG.cree.com) or call 800-533-2583.*

**CREE** 