

Color Conversion Technologies

Driver Reliability

Driver Technology for Optimized Efficiency

Interview: Insights Into Recent LED Developments

Light.



Reinvented.

The world's icons of technological advancement exist today as the result of great change and evolution. Now, it's the light bulb's turn. Introducing Samsung LED – developers of the energy-efficient, longer lasting light source of tomorrow. And at the core of LED lighting, you'll find the world's leader in semi-conductor and LED TV technology, who from LED chips to light engines & lamps, provides the complete solution for all lighting applications.

Samsung LED Lighting Solutions For more about Samsung LED lighting solutions, visit www.samsungLED.com



HV-AC



HV-AC



Ceramic



Light Engines



PAR, MR Lamps



Tubes



A19 Lamps



SAMSUNG LED



What is LEDITRON?

During the last few months we have often been asked about LEDITRON. What is it really?

A few years ago LEDITRON started as a development-cooperation between OSRAM and INSTA, both German based companies. The basic idea of LEDITRON is to replace existing lamps and dimmers with new devices to overcome several problems like dimming behavior, RFI, harmonics, etc., when installing new LED lamps to conventional phase-cutting control units, for example.

The new LEDITRON light-controller is made with a signal-modulator for a uni-directional, un-addressable mains (230V and 110/120V) communication to the LEDITRON certified lamps, which are able to decode the information from the mains line. LEDITRON uses the existing installation and enables smart controls in respect to brightness, color/RGB, and color temperature based on a 200bps information telegram structure. LEDITRON is not a classic Powerline Communication system, but a voltage/constant-current Load Line Modulation Technology (DLT, as LEDITRON is called in global standardization).

“The LEDITRON approach was applied for standardization in the field of dimming, lamps and communication”, said Bernd Siebel, Head of Product Management & Services to *LED professional* in an interview. The common policy of OSRAM and INSTA is to encourage and enable other companies to participate in the new concept. A German and PCO patent application was filed by INSTA and OSRAM (DE 102009051968). INSTA and OSRAM are willing to open the usage of the proposed concept without license fees.

The first LEDITRON samples were presented at the Light & Building 2010. The first commercial available controller-lamp set will be offered shortly, basically with a LEDITRON version for the CF-lamps.

Of course there are some technical obstacles that need to be overcome, but we are looking forward to the future development of this system.

Your feedback is always welcome to help us improve our services. We would also be happy to receive your own editorials for possible publishing.

Yours Sincerely,

A handwritten signature in blue ink, appearing to read 'S. Luger'. The signature is fluid and stylized, with a long horizontal stroke at the end.

Siegfried Luger
Publisher

PS: LED professional Symposium + Expo 2011 (LpS 2011)
The complete program is available at www.lps2011.com for downloading.

Content

■ Editorial	p 1	COMMENTARY	p 4
Imprint	p 56	News - PROJECTS	p 5
		News - PRODUCTS	p 8
		News - RESEARCH	p 22

■ INTERVIEW			
Insights Into Recent LED Developments			p 24
Interview with Eric Virey, Yole Développement			
by Siegfried Luger and Arno Grabher-Meyer, LED professional			

■ TECHNOLOGY			
Growing GaN Epi Layers on 200 mm Silicon Substrates for LED Applications			p 28
by Kai Cheng, Johan Dekoster, imec, and Sung Won Jun, Jose-Ignacio Del-Agua-Borniquel, Applied Materials			
Influence of the Phosphor Selection on Lighting Quality			p 34
by Dan O'Hare and Jonathan H. Melman, Intematix			

■ ELECTRONICS			
Highly Efficient and Reliable Power Supply for LED Street Lighting			p 40
by Wonseok Kang and Sungmo Young, Fairchild Semiconductor			
LED Drivers Help to Make LED Lighting Costs Competitive without Compromising Quality			p 44
by Steve Roberts, Recom			
LED Driving Techniques to Hit Power Efficiency Targets of TV Backlight Systems			p 48
by Werner Schögler, Markus Luidolt, Manfred Pauritsch and Peter Rust, austriamicrosystems AG			

Advertising Index

Samsung	C2
LpS 2011	p 3
Instrument Systems	p 7
Lambda Research	p 9
Kingbright Electronic Europe	p 11
Carclo	p 13
Protect-R-Shield	p 13
Curamik	p 15
LEDLink	p 17
Infineon	p 19
Shanghai-RLF2011	p 19
Fischer Elektronik	p 21
Khatod	p 22
Osram	p 23
Macroblock	p 31
Tridonic	p 33
Signcomplex	p 38
LED Light Fair Hongkong 2011	p 39
StellarNet	p 41
OLEDs World Summit 2011	p 46
Recom	p 47
LEDs 2011	p 51
Lighting Fair Korea 2011	p 53
Bodo Power Magazine	p 55
Philips-Lumileds	C3
Seoul Semiconductor	C4

LED
professional

**SYMPOSIUM
+EXPO**

LpS 2011

SIGN UP NOW!

www.lps2011.com

LED Lighting Technologies

International Winning Approaches

**27-29 SEPTEMBER 2011
BREGENZ | AUSTRIA**

CONTACT:

LUGER RESEARCH | Faerbergasse 15 | 6850 Dornbirn
T +43 5572 39 44 89 | F +43 5572 39 44 89 90
info@lps2011.com | www.lps2011.com

OSRAM
Opto Semiconductors

AVAGO
TECHNOLOGIES

e:lumix
LED Technologie GmbH

TRIDONIC
▼ enlightening your ideas



Christof Amann

The co-founder and CEO of e7, a consulting company in Vienna/Austria, is specialized in energy efficiency in buildings and energy economy. He is currently working on a study on efficient lighting systems in shops.

WILL LED HELP TO INCREASE ENERGY EFFICIENCY OF LIGHTING?

LED seems to be one of the most exciting developments in recent years. Unpleasant cold blue light that still exists in several applications, has changed to warm white or any other desired color. Efficacy has risen rapidly while costs have decreased. There is no doubt that all these trends will continue. On the political stage, expectations are high: The application of LEDs should lead to significant contributions to reach energy efficiency goals and energy savings respectively..

Producers of LED technology and applications claim that LEDs are ready for each and every field of lighting. LEDs should help to reduce energy costs significantly and the lifetime quoted by companies is very high. Published facts speak for themselves. But, why then, is LED still not used by a broad range of application and building types? Why do owners and developers of buildings not accept all these features and save a lot of energy and money?

The reason for this extensive scepticism is as simple as it is comprehensible: It is still quite risky to install a technology that is in a highly dynamic development stage. New products are introduced every week and no one knows if an LED lighting system installed in 2011 will be completely out-dated in 2012 and due to the long lifetime of the LED it will be another 5-10 years before it needs to be replaced. As long as there is no significant progress in the standardization of LED applications it is not even clear if replacement parts will be available in a few years.

Products will be cheaper and better, but building owners and facility managers are not willing to exchange more parts of the lighting system than necessary.

Another reason is that in many cases investment costs and not LCC (life-cycle-cost) determine the technology chosen for a certain application. Future savings of energy and money are still of minor importance. Time will work for the LED, but at the moment it is more expensive to have a lighting system based on the LED instead of other lighting technologies available.

However, most building owners realize that in a few years the LED will be a technology without any alternative. In the future the LED will be cheaper, the quality will be better and hopefully, products will be standardized. Today, LED is one technology amongst others and in several cases the advantages of "traditional" lighting technologies are better than the promised features of LEDs, which in many cases haven't even been proven yet. Energy efficiency gains might be huge compared to traditional bulbs but in practice the LED competes with technologies that are in the same range of efficiency or even better. If the product presentations are too optimistic it may lead to rejection.

Maybe the most important point in terms of energy efficiency is that the LED allows for new lighting concepts. LEDs are very small and can easily be controlled by computers. Light will be there where it is needed! However, energy efficiency does not necessarily mean energy savings. New possibilities for technologies will generate new applications. Some studies already state that energy consumption will rise significantly as a result of the large potential for new applications of energy efficient LEDs.

C.A.

Marni's Eclectic Style Shines Through Thanks to MEGAMAN

Sybarite, an architecture and design practice which has a diverse portfolio of clients within the retail sector, has worked with Italian fashion house Marni over the past decade to create interior identities for the company's stores worldwide. As part of Marni's design philosophy, each of its retail outlets is unique. Rather than replicating the same interior in all of its stores across the globe, the company prefers to adapt its design concept to reflect the style of each location and introduce a different color theme and feel to each installation. As a result, Marni's Sybarite designed flagship Sloane Street store differs dramatically in feel from the warmer, more earthy, design concept of Marni's Harvey Nichols interior.

Recreating the look and feel:

Torquil McIntosh, Director for Sybarite comments: "Having been created in 2008, the original interior and lighting concept that we developed within Marni at Harvey Nichols contrasted shade and light, whilst still bringing warmth and intimacy to the scheme. The color temperature of the lights was of particular importance, as it ensured that the store's warm, grey, lacquered walls, wood floors and



Architectural design studio, Sybarite, has seen an opportunity to bring drama and energy efficiency to Marni's store at Harvey Nichols, London, using the latest LED lamp technology from MEGAMAN

leather seating were as inviting as possible and the clothing looked at its best when tried on by potential purchasers."

Originally installed with PAR30 70W lamps, the lighting needed refreshing to reduce heat output and improve energy efficiencies. Not only did the new light sources have to work with existing light fittings, but they needed to recreate the warmth of the original lighting solution, whilst meeting Harvey Nichols restrictions on the total amount of power used

within the space. In consultation with MEGAMAN, Sybarite chose to use MEGAMAN's LED PAR30 15w light sources to recreate the original lighting scheme's warmth and drama, whilst reducing heat and energy consumption.

Part of MEGAMAN's LED Reflector Series, the LED PAR30 delivers low energy, wattage and maintenance cost advantages, combined with high quality lighting performance and negligible UV. In addition, with low heat output, an



Sybarite chose to use MEGAMAN's LED PAR30 15W light sources to recreate the original lighting scheme's warmth and drama. A mock-up test in the store assured that the required light levels were being obtained...



... from this low energy solution. MEGAMAN's LED PAR30 15W light sources reduce heat and energy consumption. The LED reflector lamps mimic the design of traditional light sources



excellent color rendering of Ra92 and over 90% lumen maintenance at 30,000 hours (or three years in retail terms), the MEGAMAN LED PAR30 lamps were the ideal solution for Marni's heat, energy and color rendering requirements.

New light source testing:

Due to Sybarite's concerns regarding color consistency, temperature and energy consumption, MEGAMAN set up a mock-up of the new light sources in the store. Lux levels were measured and calculations on overall energy consumption were developed, so that Sybarite and the Marni team could be reassured that the required light levels were being obtained from this low energy solution. Following a positive response from staff and customers alike to the new light source, 42 MEGAMAN's LED PAR30 lamps were fitted into the existing luminaires throughout the store, with only slight modifications required.

Torquil McIntosh concludes: "We are very pleased with the recent improvements to the lighting at our Harvey Nichols store. Not only is the end result a scheme that is welcoming and flattering, but on a practical note, less heat production has meant a reduction in the store's air-conditioning consumption as well. Thanks to MEGAMAN lamp technology, we now have a lighting solution which is not only highly energy efficient, but of a quality that we would be happy to use in any of our future retail schemes".

Reflector technology:

Providing a true eco-replacement lighting solution for traditional halogen, metal halide and incandescent applications is the driving force behind MEGAMAN's product development. Unlike many LED lamp manufacturers, MEGAMAN uses reflectors instead of lens technology to offer the most efficient LED lighting solution. The LED reflector lamps mimic the design of traditional light sources, delivering excellent distribution of light and providing energy saving compared with conventional lamps of the same output.

Using Thermal Conductive Highway™ Technology (TCH), the MEGAMAN patented LED lamp design results in longer-lasting lamps with high lumen maintenance, resulting in up to 90% of initial lumens being available at the end of the lamp life. ■

Philips Lighting Illuminates World Class Art with LED Lighting

Illumination of art is an art in itself and Philips Lighting knows how to do this best. 1,000 Philips Fortimo LED SLM modules 2000lm 33W/830 were installed in the 'MAS' (Museum aan de Stroom) in Antwerp, Belgium making the 'MAS' the first museum in the Benelux illuminating all its precious art with LED lighting.

Intensive collaboration between Lichtvormgevers, Philips Lighting, the city of Antwerp, B-architecten and Meyvaert Glass Engineering, the main contractor, has resulted in a unique lighting project: the first museum in the Benelux to be completely fitted out with LED lighting. A conscious decision was made to equip the MAS entirely with LED lighting so as to illuminate to best effect the experience aspect of all the works of art in this magnificent new museum, and also to meet present and future criteria for sustainability and energy savings.

On May 17th, 2011 the MAS opened its doors to the public. This museum is a spectacular architectural tour de force that not only houses wonderful art, but also functions as a 'boulevard' for viewing the city of Antwerp and its ports from a height.



MAS houses wonderful art illuminated by LEDs

Philips Fortimo LED Systems:

The Philips Fortimo LED SLM module 2000lm 33W/830 is the LED spot that was selected for this unique lighting project. It has particularly high color rendering and a color temperature of 3000 K. It also has a higher light output than a 100W halogen light source.

The module is dimmable. Thanks to the optimal heat management in Lichtvormgevers' luminaire, the service life of the LED module is extended. A luminaire can be modified with a color filter and dimmer filters. The purchase costs of LED lighting will be recouped in two and a half years as a result of lower maintenance and energy costs than with halogen lighting. ■



MAS is the first museum in Benelux which is completely fitted out with LED lighting

We bring quality to light.

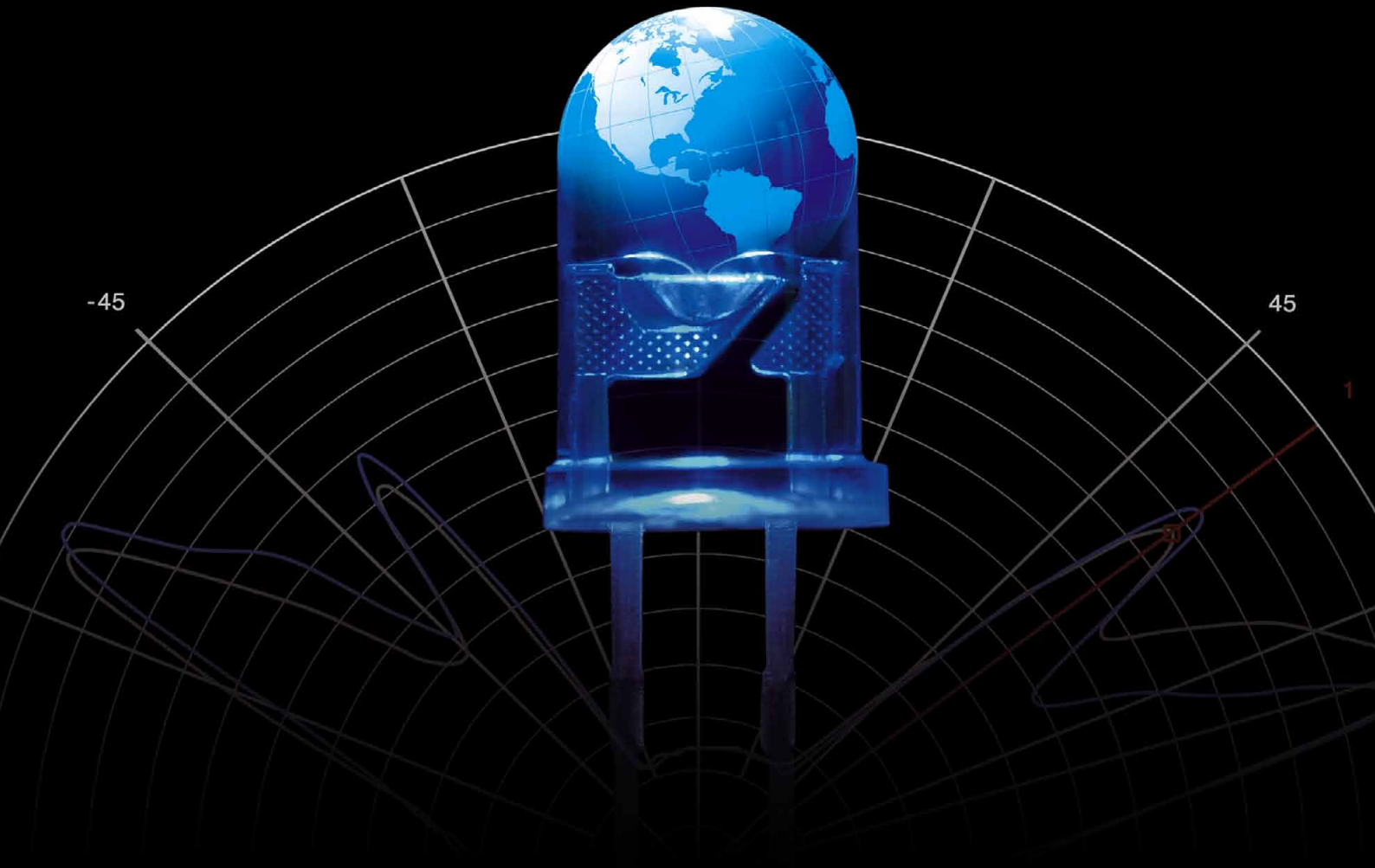

LED test & measurement solutions from the world leader

Instrument Systems continues to set the benchmark in LED metrology. Whether testing individual LEDs (standard or high-power), LED modules, or OLEDs - the global LED industry relies on us to engineer superior measurement equipment for high-speed production testing and high-performance R&D and QC applications.



Our instruments provide accurate and reliable results as per CIE recommendations and methods:

- Luminous flux [lm], luminous intensity [cd], and luminance [cd/m²]
- Chromaticity coordinates x,y,z and u'v'
- Color temperature and color rendering index
- Dominant wavelength and spectral data
- Spatial radiation pattern

 **Instrument
Systems**
light measurement

White High-Brightness LED in Durable Surface Mount Package

Avago Technologies, a leading supplier of analog interface components for communications, industrial and consumer applications, announced a white high-brightness LED in a robust surface-mount (SMT) package that simplifies manufacturing. The new ASMT-UWB1 LEDs are available in a Plastic Leaded Chip Carrier (PLCC)-2 package encapsulated in a heat-resistant silicone resin, enabling them to operate in a wide range of environmental conditions with high reliability and long operating life.

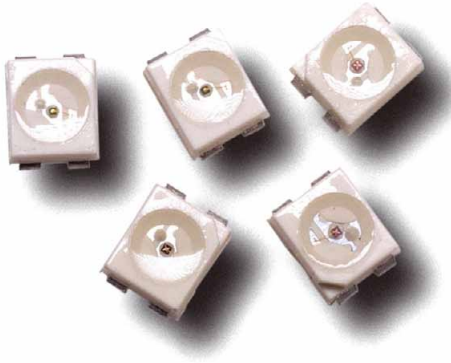

Avago's new PLCC-2 ASMT-UWB1 LEDs deliver superior light output for reduced LED count in signage, backlighting, and offer tight color uniformity for linear lighting

The superior light output of the ASMT-UWB1 LEDs enables reduced component count to cut overall system costs. This high-brightness performance, along with a wide 120-degree viewing angle, makes the LEDs well-suited for illuminated advertising, backlighting of vending and gaming machines, as well as for office automation, electrical appliances and industrial equipment.

Designers are choosing surface-mount LEDs because of their ease of assembly, compact footprint, and manufacturing flexibility, which combine to reduce overall system development costs. The ASMT-UWB1 surface-mount LEDs are packed in EIA-compliant tape and reels for simplified pick and place assembly. Each reel is shipped from a single intensity and tight color bins following the ANSI C78.377-2008 color binning structure to provide better uniformity.

The LEDs also feature a low forward voltage value, with a maximum of 3.6 V. This results in low power consumption for end-applications.

Additional ASMT-UWB1 Features:

- Compatible with reflow soldering processes
- Lead-Free and RoHS compliant
- Moisture sensitivity: JEDEC MSL 3
- Electro-static discharge sensitivity: JEDEC HBM 1000V

Availability:

Samples and production quantities are available now through Avago's direct sales channel and worldwide distribution partners. ■

Everlight Electronics Launches a COB LED Series

Everlight Electronics Co., Ltd. [TSE:2393] presents a new Chip-on-Board (COB) LED series to offer a solution to address important issues in general lighting replacement applications. Competing with previously dominating standard discrete low power, mid power, and high power LED components, Chip-on-Board LEDs are predicted to take on a third of all LED A-lamp applications in 2011.

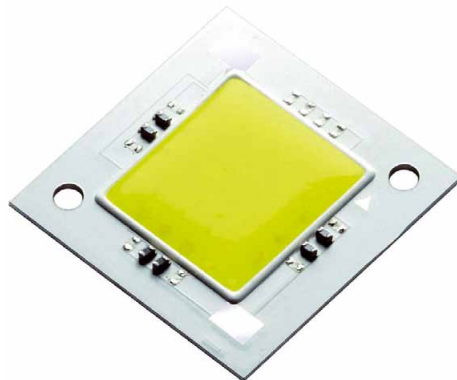

Everlight claims the new COB LED series to be the Ultimate light source for 40W and 60W A-bulb replacement, recessed lighting and other indoor general lighting applications.

To replace 40 W and 60 W incandescent A-bulbs, LED A-lamps need a light source that exhibits high efficiency, sufficient lumen output, high CRI, color uniformity, and sufficient light distribution to maintain a comfortable and uniform lighting environment – all at consumer acceptable prices. With its new COB Series, Everlight Electronics has created an ideal LED to address major

challenges posed when designing an LED A-bulb: heat dissipation, color shift over time and temperature, light distribution and cost.

Everlight's COB LED series is a MCPCB substrate based multi-chip solution that boasts a >95 lm/W at 3000 K CCT and >80 CRI. Less layers of thermal resistance result in lower overall junction temperature. A new patent pending Everlight innovation is able to address the Hot/Cold Factor, the color uniformity as related to change in temperature. From 25°C to 85°C, the Everlight COB LED can control CCT shift to within 200 K CCT for all wattages - the first of its kind that is able to restrict the shift to such a narrow range. A large single light emitting source means less diffusion needed to achieve high uniformity and light distribution. And finally, due to high performance, aggressive commercial strategy, and less processes and material required for assembly, the Everlight chip-on-board technology has nearly achieved the industry target of 200 lm/\$ for LED light sources.

Everlight is fostering closer working relationships between our R&D, Sales and Marketing teams to meet and exceed our customer's expectations in both product offering and technology. The COB LED Series is expected to satisfy the fast-growing market of general lighting LED replacement applications. ■

GE's New Infusion™ Module: Fullest Range of Lumen Packages and CCTs

GE Lighting's new Infusion™ LED module series opens up design possibilities and revolutionizes the way light-critical customer spaces can be exhibited. With higher lumen packages and CRI options, plus the ease of installation, these modules represent a major breakthrough in commercial lighting technology, expanding potential applications for LED lighting solutions in retail, museum, office and other environments where light quality is vital to the user experience.

Ideal for spotlighting, down lighting, track, and accent lighting, the Infusion LED modules offer lighting designers and merchandisers a long-lasting, controllable, low maintenance

Top 5 Reasons to Buy TracePro

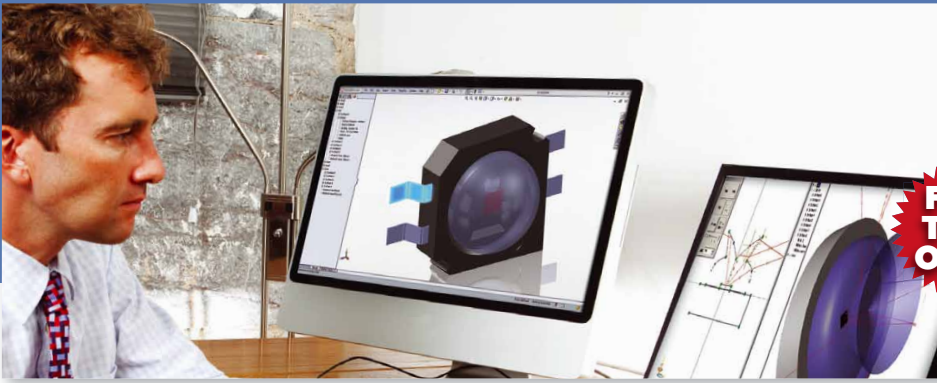

Free Trial Offer

For a 30 Day Trial Offer Visit www.lambdaresearch.com/trials

TracePro® Software - Design and Analyze Any Optical/Illumination System

1. Easiest-to-use opto-mechanical software with full CAD integration
2. Simple Interactive Optimizer: sketch geometry, set variables, digitize targets, optimize
3. Lowest entry price for a permanent license
4. Multiple editions to fit your needs, with an upgrade path as you need more capability
5. Define your optical properties directly in SolidWorks® by using our TracePro Bridge Add-in



TracePro is a registered trademark of Lambda Research Corporation and SolidWorks is a registered trademark of Dassault Systemes

Lambda Research Corporation, 25 Porter Road, Littleton MA 01460 (+1) 978-486-0766 www.lambdaresearch.com

LED solution to create attention-grabbing, yet functional, displays and applications. Infusion LED modules can be even more efficient than many halogen, ceramic metal halide, and CFL solutions when included in an efficient luminaire design. The wide range of light output and color temperature options create additional design opportunities.



GE's New Infusion LED modules are available in 1000, 1500, 2000 and 3000 lumens

GE Lighting is the first manufacturer to offer this range of lumen packages and color temperatures in a fully replaceable module with a common size. The Infusion LED modules are available in 1000, 1500, 2000

and 3000 lumens, in color temperatures of 2700 K, 3000 K and 4000 K, and CRI options of 80 and 90. They are also dimmable and turn on instantly.

LED technology is being adopted in many professional lighting applications, though some designers remain reticent about specifying LED everywhere in their schemes because servicing and upgrading the luminaires is often a challenge. The new Infusion LED modules solve these issues as luminaires can be easily maintained and upgraded. The module offers a twist and lock fit that is as simple as replacing a regular light bulb – no additional tools are necessary. This simple twist fit mates the module with the housing and provides all necessary thermal, electrical and mechanical connections.

The easy interchangeability has other benefits as well. "Even after a luminaire is installed, the Infusion module can easily be changed out to showcase different options," says Joshua Gildea, product manager for LED Indoor Lighting, GE Lighting. "This overcomes the inflexibility of integrated luminaires, giving merchandisers the ability to vary color temperatures and beam angles by simply swapping out modules." ■

Luminus Devices and T-Opto: 175 W Metal Halid Equivalent LED Light Source

Luminus Devices, Inc., and T-Opto, a Division of Toyota Tsusho America, announced the introduction of the SoloLux high output LED module, a high efficacy sub-system for high lumen general lighting applications that typically utilize a 175 W metal halide source. SoloLux is designed for indoor and outdoor installations requiring many thousands of lumens such as parking area, roadway, canopy, high bay and high ceiling down lights. The patent-pending module produces up to 6,500 lumens from a single source, which reduces fixture cost and complexity when compared against alternate solutions that use arrays of low power LEDs.

Preliminary Specifications (datasheet and samples coming soon):

Input Current	CCTs	Lumen range
3.0 – 6.0 A	6,500 K	3,000 – 6,500 lm
	5,700 K	3,000 – 6,500 lm
	4,500 K	2,700 – 6,000 lm
	3,000 K	2,250 – 4,500 lm



SoloLux is a high output modular solution that incorporates all the benefits of Luminus' Big Chip technology with the simplicity of a plug & play solution

"SoloLux sets a new standard for LED modules by providing the lighting community with a single source, field upgradeable solution with real optical punch," said Jim Hunter, Vice President and General Manager for Global Commercial Markets at Luminus Devices. "The module is based on Luminus Big Chip LED technology, which provides our lighting customers with the opportunity to develop creative and differentiated high performance fixtures. We are seeing real innovation in the marketplace with the technology, such as indirect lighting fixtures that are low glare and eliminate multi-source shadowing."

Michael Handerhan, General Manager of T-Opto, adds "Field upgradeability is a real key to the strategy behind the SoloLux. As LED performance continues to improve, fixture performance can be upgraded by replacing the chip-on-board LED with a standard screw driver. The benefits to our customers in accelerating time to market are obvious, as the SoloLux comes with integrated heat sinking and an electrical interface to standard ballasts. In addition, we have created reference designs for our customers, including custom optics, for targeted applications such as outdoor area lighting and high bay."

SoloLux is available in color temperatures ranging from warm to cool, and is in process of attaining LM-79, UL1598 and ULIP66 accreditations. SoloLux will be available for sampling this summer with volume availability shortly thereafter. ■

LED Light for Every Retail Space

Vossloh-Schwabe's new built-in LED system for retail lighting. The VS system consists of LED modules of various outputs and color temperatures, matching electronic ballasts and further accessories such as graphite film for optimum thermal connection of cables or connecting active 12 V cooling components. VS also provides DALI-compliant, dimmable ballasts. The LED system is suitable for use in reflector luminaires in a broad range of applications. Apart from guaranteeing a very long service life, the LED system also delivers UV- and IR-free light with good CRI values.



VS retail modules

Vossloh-Schwabe's new built-in LED system for retail lighting. LED technology delivers many advantages:

- Instantaneous light: no delay on being switched on nor a warm-up phase following disconnection from the mains
- Gentle on products: UV- and IR-free
- Longer lamp service life: up to 50,000 hours
- Easily dimmable for fast changes of lighting scenes
- Color temperatures to suit every product group: clothing, meat, sausages, cold cuts, fish, vegetables, etc.
- True-color displays: excellent CRI values to suit the product type
- Negligible drop in luminous flux during the lamp's service life, removing the need to replace lamps
- Extremely energy-efficient
- Simple luminaire construction with maximum safety guaranteed by safety extra-low voltage (SELV)

Highly versatile to suit any application

Powered by constant current, the LED module at the heart of the LED module system is available in three array versions with 12 to 16 high-performance LEDs and various color temperatures (2700 K to 4000 K). In addition, the compact module is very flat and measures only 50 mm or 56 mm in diameter.

Simple installation and slim-line luminaire designs

The lamp's low installation depth and flat geometry enable very slim-line luminaire designs since the module can be mounted directly on top of heat-dissipating surfaces.

One luminaire design to suit various lighting needs

Featuring a single internal structure and identical dimensions for easy module exchange within the luminaire, LED module is available in various color temperatures. As a result, lighting can be easily tailored to suit the respective application (food/non-food).

Independent control gear for luminaires with remote technology

Independent control gear makes it possible to use greater cable lengths between the driver and the LED module, thus enabling smaller, slimmer luminaire designs with remote technology.

Highest operating safety

LED module is operated using safety extra-low voltage (SELV). Fewer measures are therefore required to ensure protection against accidental contact and compliance with relevant standards for simpler luminaire construction.

Highest degree of thermal safety

Thermal protection circuitry ensures the operating current is reduced should the temperature at the tc point attain a critical value.

Reduction of Failure Rate

Optimized heat dissipation and thermal protection circuitry ensure components are subjected to less thermal stress, which minimizes the failure rate and prolongs the service life of the module.

Convenient and fast wiring

The 12 V interface for active cooling components facilitates fast and easy connection.

Superior mechanical stability

LED module is shock- and vibration-resistant. Three mounting points in the form of metal bushings permit safe and reliable mounting of the module, with the components ideally protected by the plastic casing. In addition, the metal bushings enable optimum connection of a heat sink.

Kingbright's KPHB-1608 series Bi-colour SMD-LED im 0603 package

Features:

Dimensions = 1,6 mm x 0,8 mm x 0,5 mm

Available in various colour combinations

Luminous intensity up to 230 mcd @ 20mA

By the low construction height this bi-colour SMD-LED is suited especially for backlighting at Keypads, Keyboards or LCD's

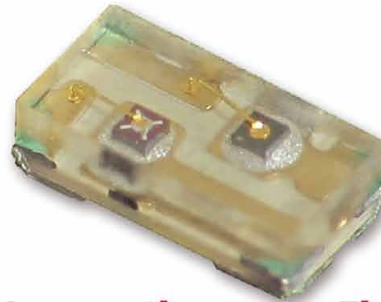

Quality — Efficiency — Innovation — First-class service

Kingbright Electronic Europe GmbH • Lindenau 7 / Gewerbegebiet • D-47661 Issum • Phone: +49 (28 35) 44 46-0 • Fax: +49 (28 35) 44 46-29

Made for ease of use

LED module is fitted both with push-in terminals for releasable connecting cables and with an integrated 12 V interface for connecting external cooling units (LED module 404 and 405).

Tested for safety

LED module is VDE-certified in accordance with EN 62031, the relevant safety standard for LED modules.

Simplification of the luminaire approval process

Considerably easier luminaire approval in accordance with EN 60598.

LED module's performance is not just restricted to retail lighting. For instance, the system is equally suitable for use in reflector luminaires, flat downlights, façade lighting and pendant luminaires in which the LED driver is not integrated into the LED module, but is installed in a separate unit. This makes the LED module suitable for the most diverse applications, including domestic lighting. ■

LEDON OLED Lighting: World Most Powerful OLED Lighting Module

On the OLED Lighting Design Summit 2011 in London LEDON OLED Lighting presented a breakthrough in OLED Lighting, the first 1001 lumen lighting module prototype for professional lighting applications.



LEDON OLED's new Module consists of nine OLED elements (provided by LG Chem) combined with an optimized out coupling structure.

The Organic Light Emitting Diode (OLED) technology is the first real area light source technology in history. OLED lighting elements allow complete new lighting integration opportunities in different applications. Due to the slim form factor, it is possible to realize lighting solutions with very thin elements and high lighting homogeneity.

For professional applications, e.g. in office areas, the actual demonstrated luminous flux levels of OLED modules are too low. A practical barrier for OLED application in this field is a luminous flux area density above 10,000 lumen/m² in combination with high total luminous flux. The presented demonstrator overcomes this limit and combines outstanding OLED panels with an optimal optical, electrical and mechanical integration concept with a slim form factor to achieve the best results for large area lightings.

The prototype delivers 1001 lumen at a professional relevant color temperature of 4077 K and a high efficacy of over 30 lm/W in a compact dimension of 300x300 mm² with a thickness of 5 mm, nine OLED elements

(provided by LG Chem) combined with an optimized out coupling are integrated in this module package. The average luminous flux area density is over 11,000 lumen/m².

"The presented prototype shows the potential of OLEDs for professional lighting applications in a remarkable way. The 1001 lumen package in combination with a neutral white color temperature and high efficacy in one module package is an important breakthrough", stated Joerg Amelung, general manager of LEDON OLED Lighting.

LEDON OLED Lighting in cooperation with Zumtobel Lighting GmbH also shows a professional pendant luminaire concept at the fair based on these lighting elements. This pendant luminaire was designed by Continuum Milan and delivers in total more than 1100 lumen luminous flux.

Additionally, the start of a ready-to-market lighting series will be shown at the fair, the LUREON I lighting series. The LUREON I OLED lighting series combines a slim form factor (< 3.5 mm) and a high luminous flux area density (5000 lm/m²) for illumination applications. The elements can be combined with an adaptive driving system for easy application integration solutions. The modules can be delivered in different formats (up to 300x300 mm²) and in two color temperatures (4200 and 2700 K) and show excellent lighting quality without angular color dependence. The lighting series is dedicated to the integration in the application fields of Effect lighting, Presentation lighting, Architectural lighting or in Design luminaires. The elements can be delivered as engineering samples starting now, production will start in August. ■

Intematix Unveils ChromaLit with New Core, Sphere and Candle Shapes to Illuminate LED Bulbs

Intematix, a leading innovator of patented phosphors and phosphor components for high-quality LED lighting announced three-dimensional additions to its ChromaLit Collection. The new forms and light output levels improve the quality of light from LED bulbs, lamps and innovative fixture designs.

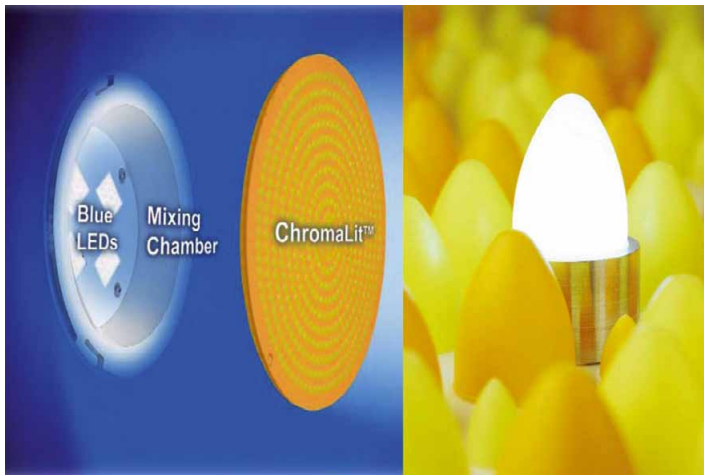

Main benefits include:

- High color quality and color consistency
- Glare-free LED bulb and fixture design
- Unprecedented design freedom for solid-state lighting
- Streamlined supply and production of LED lighting systems
- Up to 30 percent higher system efficacy compared to conventional LED lighting designs
- Improved thermal performance
- Customizable shape, size and color

“Our newest ChromaLit products offer almost 360 degree light distribution, effectively serving as the core of the next generation LED light bulb,” said Julian Carey, Intematix Director of Marketing. “In the past, bulb designs have presented challenges to LED lighting designers. Our latest remote phosphor solutions accelerate the development of products with high light quality, high efficacy and smooth and broad radiation patterns needed by the marketplace.”

The natural warm white light, which provides realistic rendering of colors and skin tones, comes from the new “Brilliant Mix” LED concept from OSRAM Opto Semiconductors



Intematix extends the ChromaLite system (basic configuration can be seen left) with several 3D shapes for applications like LED bulbs (right)

spectrum from 2700 to 4000 K. Depending on the required luminous flux, a different number of these LEDs can be combined to produce warm white feel-good light of high quality that will set new standards in general illumination applications.

This new LED concept is backed by in-depth OSRAM know-how in terms of the high-power Oslon SSL LED, expertise in color mixing and control and project-specific customer support. The main applications for the new concept include high-quality lighting solutions for residential and commercial premises such as shops and offices. The high quality of the light is based on the combination of a pleasant warm tone and very high color rendering properties. The high CRI ensures that colors and skin tones appear in artificial light as natural as they do in normal daylight. Test colors R9 (saturated red) and R13 (skin colors) are crucial for the natural rendering of red and skin tones. With CRIs of 78 and 98 respectively they have much higher values than most conventional light sources. The typical value for the general color rendering index Ra (averaged sum of test colors R1 to R8) is 92 at a color temperature of 2700 K. The luminous efficacy is also exceptionally high at more than 110 lm/W. For a comparable color temperature and comparable CRI that is 30 percent higher than warm white LEDs that produce white light using the principle of phosphor conversion. Even in a retrofit lamp system this concept can achieve 100 lm/W at system level.

Oslon SSL LEDs in EQ-White and Amber are used in the “Brilliant Mix” concept. Measuring just 3 mm x 3 mm, these LEDs are among the smallest in the 1 W class and can be closely clustered. This makes color mixing easier and also improves the optical design at system level.

Compared to conventional LED designs, where blue chips are coated with a phosphor compound, the ChromaLit Collection leverages a phosphor composite separated from the blue LED energy source. The latest ChromaLit products employ compound optical forms and offer a choice of wide radiation patterns ideal for bulb, pendant, lantern, decorative and other lighting applications. ■

Osram Applies “Brilliant-Mix” LED Concept to Parathom Pro LED Lamps and PrevaLED System

Warm white light with a high luminous efficacy (110 lm/W) and a color rendering index (CRI) of more than 90 are the result of the new “Brilliant-Mix” concept from OSRAM Opto Semiconductors. The intelligent color mix based on powerful Oslon SSL LEDs in EQ-White and Amber covers a broad white

carclo

technical plastics

USED ON THE FUTURE OF LIGHTING FOCUSED ON THE FUTURE OF LIGHTING FOCUSED ON THE FUTURE OF LIGHTING FOCUSED ON THE FUTURE OF LIGHTING

Opticselect
www.carclo-optics.com

600 Depot Street
Latrobe, PA 15650
USA

T +1 724 5396982
F +1 724 5372534

103 Buckingham Avenue
Slough, Berkshire
SL1 4PF

United Kingdom
T +44 (0)1753 575011
F +44 (0)1753 811359
E sales@carclo-optics.com
W www.carclo-optics.com

PROTECT-R-SHIELD

The Optically Clear Conformal Coating

Protects LED and Printed
Circuit Boards from
Environmental Damage

MOISTURE • DUST • SALT SPRAY • CORROSION

Let PRS Be Your Solution Provider

- Lifetime, non-yellowing conformal coating
- Negligible lumen loss when coated over LEDs
- Patent-pending optical lens attachment
- Low to high volume production - let us quote

protect-r-shield®

www.protectrshield.com • tel: (888) 257-4780



computer-controlled robotic
selective dispensing
the Precision Conformal Coating

To make it as easy as possible for customers to select and order the appropriate LEDs we have developed a logistical module concept. Christian Neugirg, Business Development Manager SSL at OSRAM Opto Semiconductors explains: "Planning and implementing LED lighting systems requires an immense amount of calculation, so we are relieving our customers of this tiresome task. Customers simply have to tell us the light color, the temperature of the board and the luminous flux they want to achieve, and our logistical module concept then works out which LEDs and how many need to be ordered to meet these requirements perfectly." The semiconductor specialist also offers application support for selecting the correct electronic control. Lamp and luminaire manufacturers therefore have new opportunities to create LED lighting solutions with warm white light and high brightness levels. Everything is now in place for LEDs to be used more and more for general illumination purposes without having to compromise on lighting comfort.

The "Brilliant Mix" concept has already been implemented in the Parathom Pro Classic A 80 LED lamp and in the PrevaLED system from OSRAM. These demonstrate the high quality of light that can now be achieved with LEDs. ■

Philips to Unveil True LED Replacement for the 75-watt Light Bulb

One year after the presentation of the A19 - 60W equivalent LED bulb at Light+Building 2010, Royal Philips Electronics, the industry leader in LED lighting solutions, unveiled the Philips EnduraLED A21 17-watt light bulb tomorrow at the LIGHTFAIR® International tradeshow, May 17-19, 2011. Designed to replace a 75-watt incandescent bulb, while reducing energy consumption by 80% and lasting 25 times longer, the Philips EnduraLED A21 17-watt marks another important milestone in LED lighting technology for everyday use.

"We continue to test the boundaries of LED innovation with exciting products that provide energy efficiency, ambiance and extraordinary

reliability," said Ed Crawford, General Manager of Lamps for Philips Lighting North America. "Once again we have demonstrated that consumers do not have to wait for quality alternatives to the incandescent or to sacrifice the soft white light they have become accustomed to because LED can deliver all the benefits without compromising quality."



Philips EnduraLED A21 17-watt light bulb was presented at the LIGHTFAIR® International tradeshow, May 17-19, 2011

The EnduraLED A21 17-watt is the latest addition to Philips' comprehensive portfolio of light-emitting diode (LED) bulbs that can efficiently replace traditional incandescents. These include 25 W and 40 W equivalents, as well as the ENERGY STAR-qualified Philips EnduraLED 12.5-watt bulb, the world's first commercially-available 60-watt replacement.

The EnduraLED A21 17-watt, which uses the company's high-power, next-generation LUXEON LEDs, has also been developed to meet or exceed ENERGY STAR qualifications for an LED-based replacement for the 75-watt incandescent light bulb. Those specifications call for delivering 1100 lumens with just 17-watts of electricity, a color temperature of 2700 K, a color rendering index (CRI) of 80, and a rated life of 25,000 hours. The new bulb will be submitted to ENERGY STAR in the coming months for qualification testing.

Philips estimates that about 90 million 75-watt incandescent light bulbs are sold annually in the United States. Switching to this LED replacement has the potential to reduce energy use by 5,220 megawatts of electricity, a cost savings of approximately \$630,000,000 annually. According to Philips estimates, switching to the EnduraLED 21 17-watt could also eliminate 3.2 billion metric tons of carbon emissions annually, or the equivalent of removing nearly one million cars from the road.

As with all bulbs in the Philips LED lighting family, the new EnduraLED A21 17-watt has a rated life of 25 times longer than a standard incandescent bulb. Over its lifespan, the EnduraLED A21 17-watt could save a business or household about \$160 per bulb. Available during the fourth quarter of 2011 in the US, the manufacturer's suggested retail price for consumers has not yet been finalized but is expected to be in the range of \$40- \$45.

With this latest addition to the Philips portfolio, consumers and businesses have more choices than ever that can reduce energy costs over the traditional incandescent bulbs. In addition to offering familiar soft white light, the Philips EnduraLED A21 17-watt fits into existing fixtures and works with standard dimmers, giving consumers a simple, long-lasting solution for the home. For those within the retail or hospitality sector, the bulb will provide a substantial return on investment, through extended bulb life and reduced energy and maintenance costs. ■

Osram Sylvania Introduces Next Generation of Omni-Directional LED Lamp

Continuing to lead the way in providing cutting-edge LED solutions, North American lighting leader OSRAM SYLVANIA is proud to introduce new omni-directional LED A-Line lamps. The latest addition to OSRAM SYLVANIA's ULTRA High Performance Series, the new omni-directional LED A-Line lamps offers a long-life, energy efficient alternative to conventional lighting sources such as incandescent, halogen and compact fluorescent lamps (CFL).

Dimmable and available in three low-power wattages, the new LED A-Line lamp offers a true substitute for 40, 60 and 75-watt incandescent lamps. Producing equivalent lumen output and a similar distribution pattern, the new ULTRA High Performance LED A-Line lamp provides up to 82 percent energy savings over traditional incandescent lamps. With a rated life of 25,000 hours, the LED lamps lasts up to 25 times longer than traditional light sources, resulting in further cost and energy savings.



Osram Sylvania's LED A-Line lamp offers a true substitute for 40, 60 and 75-watt incandescent lamps

“These new products demonstrate our commitment to LED technology and the understanding the market requirements,” said Phil Rioux, general manager of the Consumer Lighting SSL business unit. “Our advanced engineering department is focused on providing innovative SSL solutions for the future.”

LED Lamp Wattage	Dimmable	Lumens	LPW	CCT	CRI	Equivalent Incandescent
8	No	480	60	2700K	85	40W
8	Yes	450	56	2700K	85	40W
13.5	No	825	60	2700K	85	60W
13.5	Yes	800	60	2700K	85	60W
13	Yes	1100	84	2700K	83	75W

The ULTRA High Performance Series omni-directional LED A-Line lamp features a high color rendering index (CRI) of 85 and a 2700 K warm white color temperature that rivals incandescent and halogen light sources. These combined features make the new LED A-Line lamp an attractive option for residential applications, hospitality, healthcare, and retail environments.

Continuing to lead the way in providing cutting-edge LED solutions, North American lighting leader OSRAM SYLVANIA is proud to introduce new omni-directional LED A-Line lamps. The latest addition to OSRAM SYLVANIA's ULTRA High Performance Series, the new omni-directional LED A-Line lamps offers a long-life, energy efficient alternative to conventional lighting sources such as incandescent, halogen and compact fluorescent lamps (CFL).

Dimmable and available in three low-power wattages, the new LED A-Line lamp offers a true substitute for 40, 60 and 75-watt incandescent lamps. Producing equivalent lumen output and a similar distribution pattern, the new ULTRA High Performance LED A-Line lamp provides up to 82 percent energy savings over traditional

efficiency solutions by direct bond copper

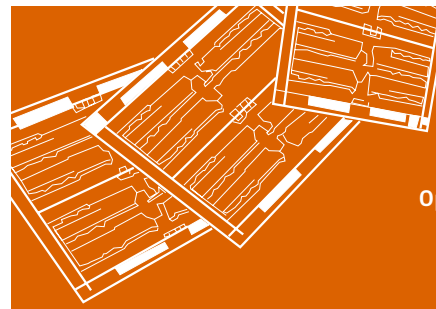

High thermal conductivity
Excellent for chip on board
Optimized heat spreading

DBC SUBSTRATE

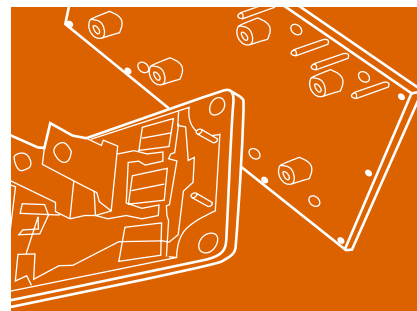

Highly integrated cooler
Outstanding thermal performance
Customized design

DBC COOLER

curamik electronics GmbH
Am Stadtwald 2
D-92676 Eschenbach
Phone +49 9645 92 22 0
info@curamik.com
www.curamik.com

A division of
 ROGERS
CORPORATION

incandescent lamps. With a rated life of 25,000 hours, the LED lamps lasts up to 25 times longer than traditional light sources, resulting in further cost and energy savings.

“These new products demonstrate our commitment to LED technology and the understanding the market requirements,” said Phil Rioux, general manager of the Consumer Lighting SSL business unit. “Our advanced engineering department is focused on providing innovative SSL solutions for the future.”

The ULTRA High Performance Series omni-directional LED A-Line lamp features a high color rendering index (CRI) of 85 and a 2700 K warm white color temperature that rivals incandescent and halogen light sources. These combined features make the new LED A-Line lamp an attractive option for residential applications, hospitality, healthcare, and retail environments. ■

Light Boltz Made Debut During Lightfair

American Illumination, Inc.® introduced the modern, sleek Light Boltz LED engine during Lightfair to widely receptive audiences. With a cylindrical shape and a integrated heat sink, this LED engine is perfect for lighting applications where high light output and maximum efficacy are required, without sacrificing aesthetics. The Light Boltz is an attractive, contemporary LED module with a satin silver finish. The overall design lends itself well to recessed lighting designs, up-lights, bollards, track lighting, spot lighting and more.



Cylindrical in shape, the Light Boltz LED Engine saves energy without sacrificing design and offers a high punch of light

Harnessing triple Cree XP-G Series LED's, the UL-pending Light Boltz features a slim profile at 2" OD x 2.5" L (12V AC/DC model) or 3.5" L (120VAC model) while packing a punch similar to a PAR20 bulb, thus giving specifiers and designers a wide range of performance options that all share a common footprint. The Cree XLamp XP-G LED delivers unprecedented levels of light output and efficacy for a single-die LED, and in the Light Boltz has been tripled for maximum illumination capabilities.

Lighting engineers and designers will enjoy the Light Boltz LED engines for contemporary fixture designs, but the benefits go well beyond aesthetics. The Light Boltz includes various features such as an internal thermal regulator with a self-contained constant current driver. Available in 2750 K (Warm White), 3950 K (Natural White), 6000 K (Cool White), or Single Color (Red, Blue, Green or Amber), it can be utilized for applications such as grow lights, museum spotlights, track lights, architectural down lights, and much more. It offers the ability to interchange optics in the field and is also tapped for indoor tracks, recessed lighting fixtures or outdoor landscape fixtures. When used indoors, the Light Boltz can be implemented standalone for a bold look, or can be integrated into a high-end luminaire. ■

CamSemi Moves into LED Lighting with New Driver ICs

CamSemi announced the launch of the C3120 family of LED driver ICs and its intention to become a major player in one of the fastest-growing sectors of the lighting market. The new family has been specifically designed to drive an advanced boost/flyback topology to deliver the three essential performance requirements for volume LED applications: 'best in class' current regulation, high efficiency and power factor correction.

The three new driver ICs target 4, 8 and 12 W designs making them ideal for a wide range of emerging solid-state lighting products: from replacements for halogen spotlights used in retail displays and incandescent lamps for domestic/residential use to fluorescent tubes for commercial and industrial applications.

The C3120 family has been designed to help LED lighting manufacturers fully exploit the cost advantages of bipolar transistors when developing high efficiency, simpler and more cost-effective solutions. The boost/flyback topology coupled with quasi-resonant switching and innovative power-saving techniques help to deliver efficiencies greater than 80% and offer power factors greater than 0.9 to easily meet emerging regulatory requirements. The new devices also make

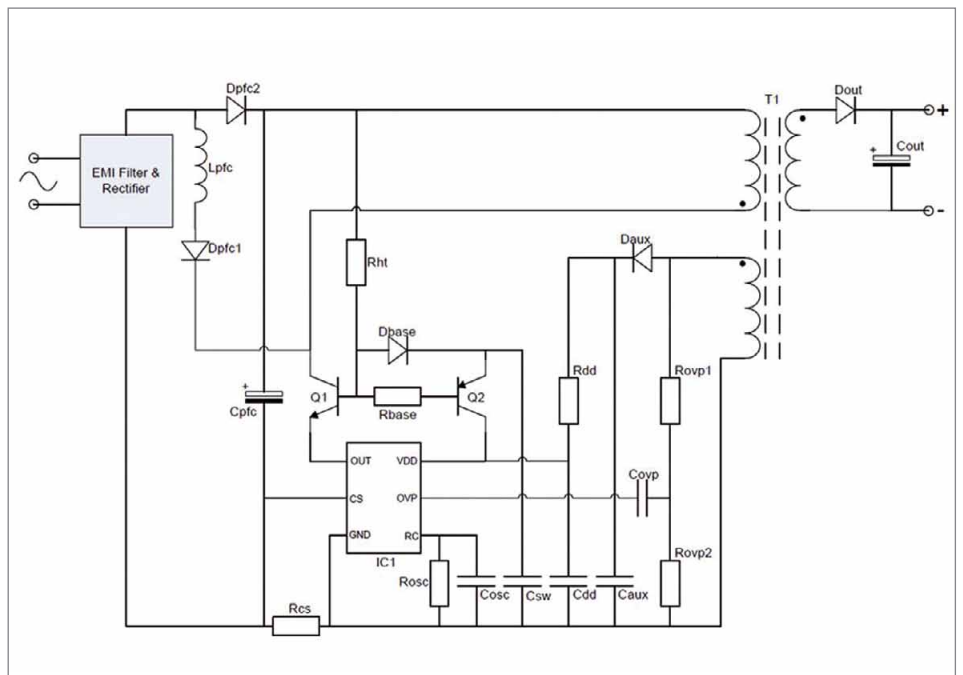

A typical application circuit with a new CamSemi C312x series LED driver



Secondary Optical Solution

- ✓ Wide range of standard optics for different LEDs.
- ✓ Compatible MCPCB with our standard lenses.
- ✓ ODM and OEM services is available for: Custom secondary optics, Custom housing components, Semi-module product, Custom MCPCB.

CREE

CITIZEN
Micro HumanTech

EDISON

PHILIPS
LUMILEDS

NICHIA

OSRAM

SAMSUNG

SAMSUNG LED

SEOUL

www.ledlink-optics.com
service@ledlink-optics.com

T:+886-2-8227-6126
F:+886-2-8227-6127

Address: 15F, No. 655, Bannan Rd., Chung-Ho Dist, New Taipei City, Taiwan

use of CamSemi's novel primary side sensing (PSS) technology - already widely used in today's top specification mobile phone chargers - to eliminate optocouplers and other components. This approach saves BOM costs while also providing an isolated solution for new mains-powered lighting products.

"CamSemi is already a global leader in the development and supply of power management ICs for more energy-efficient, low cost power supplies and plans to mirror that success in the solid-state lighting sector. The new C3120 controllers offer tight tolerance constant current operation for excellent LED control plus a high degree of configurability allowing lighting designers for the first time to target a wide range of applications at minimum cost," said David Baillie, CEO of CamSemi.

The C3120 family also helps maximize end product safety with advanced features such as protection against over-temperature and output overvoltage to guard against a LED failure. Output short-circuit protection has also been incorporated to further simplify designs and reduce system costs. ■

Exclara Launches High-Voltage LED Driver Solution

Exclara, Inc., a leader in advanced LED driver ICs and modules, announced a breakthrough in solid-state lighting (SSL) with the launch of the Exclara HVX family that enables the lowest cost, smallest size LED driver solutions while improving efficiency, power factor and quality. Using Exclara's patented high-voltage driver technology, the HVX family makes high-voltage LED driver economically and physically effective to use in a commercially available product, paving the way for mass-market, sub-\$10 LED lights.

The first member of the new family, the EXC100, is a single-chip power supply for high-voltage LEDs. This lowest-cost driver supports low parts count. Only a handful of supplementary components are needed, thereby reducing driver size and allowing it to fit into the base of a small bulb or on the LED board itself. For example, a 10 W power supply only requires 10 to 15 components including the PCB. Integration of all control

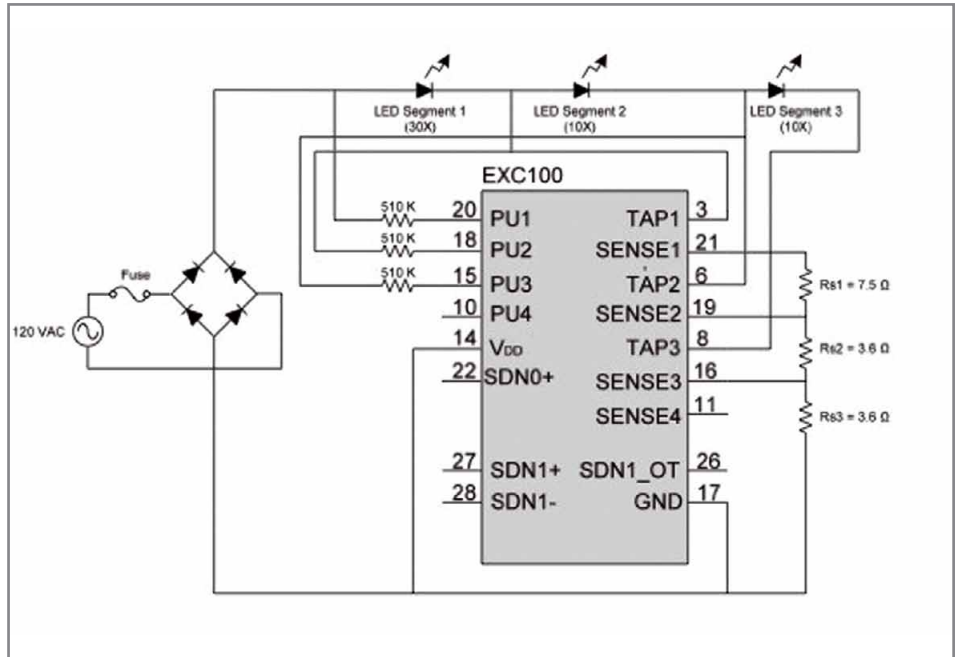

Exclara HVX solution using EXC100 driver

functionality required for high-voltage AC operation leads to lower cost solutions. This also allows a smaller overall power system and very low bill of materials (BOM) cost.

The HVX family has been specifically designed to deliver – and improve upon -- the four essential performance requirements for volume LED applications: high efficiency, power factor correction, dimmer support and low EMI with maximum reliability and long life. HVX drivers achieve efficiencies of 90-96%, while the typical flyback DC system achieves 75-82%. HVX-based systems offer a high power factor because there is no utilization of reactive components, and HVX achieves even higher power factors as the internal controller performs the power factor correction. HVX includes dimming capability and is compatible with most dimmers on the market. As for EMI, while HVX performs internal switching, it is implemented in a way that does not produce large harmonics and meets FCC requirements without the use of external components.

"We forecast that the market for LED driver ICs for lighting applications will grow at nearly 50% compounded annually, but that segment needs innovative and low-cost solutions that also meet industry and regulatory performance standards," says Dr. Tom Hausken of Strategies Unlimited, a market research firm specializing in LEDs and LED lighting.

"The transformation of lighting technology—with the Edison bulb giving way to the LED—has been predicted for more than a decade. The challenge behind LED lighting, though, has been the inability to produce a high-performance product at a low enough cost to open the door to mass market penetration," said Shri Dodani, president and CEO of Exclara. "Exclara is the first company to offer a LED driver solution that is economically and physically effective to use in commercial systems. It will usher in the sub-\$10 LED bulb and pave the way for widespread adoption of LED lighting."

The EXC100 supports operation either directly from AC line or from dimmers, making it an excellent drop-in choice. An HVX-based driver system does not require use of an electrolytic capacitor and therefore can match the operating life of LEDs. It also supports millions of "on/off" actions without failure, a limitation in the traditional DC based drivers.

The EXC100 also helps maximize end product safety with advanced features such as protection against over-temperature and output overvoltage to guard against a LED failure. It complies with both UL/CE and FCC requirements in the USA and with equivalent counterparts worldwide. ■



New LED Controller with Ultra-Low Dropout Voltage



BCR205W is Infineon's brand-new linear LED controller. Combined with an external output stage, it is the best way to drive low-power LEDs up to 80mA.

- Ultra-low voltage overhead of only 0.2V – output stage included – is 6 times lower than mainstream LED drivers
- Capable of driving longer LED strings – such as 3 LEDs in 12V applications – and of reducing LED V_f dependency
- Perfect fit for channel letter, decorative and architectural lighting plus gambling/vending machines

To learn more about our LED driver portfolio for general lighting, please visit www.infineon.com/lowcostleddrivers

Atmel Launches Power-Efficient Multi-String LED Drivers

Atmel Corporation, a leader in microcontroller and touch solutions, announced a new family of intelligent multi-string LED drivers for the backlighting and solid state lighting markets. The comprehensive portfolio of Atmel LED drivers offer design engineers industry-proven efficiency optimizer (EO) technology, flexible dimming options, scalability across wide range of power levels, user programmability and lower bill of material (BOM). These features are ideal for rapidly growing LED applications in direct and edge-lit LCD TVs, PC monitors, industrial, military and avionics displays, as well as general illumination in the commercial, residential, industrial and infrastructure market segments.

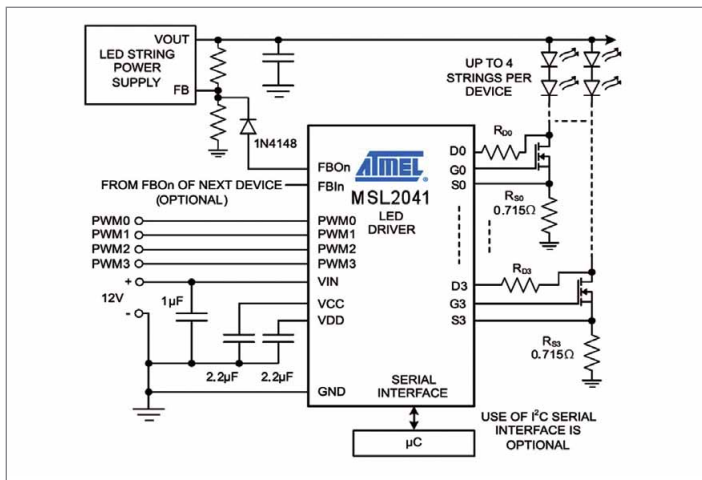

Application circuit for Atmel's MSL2041 four channel LED driver for general lighting applications

The LED drivers incorporate Atmel's patent-pending efficiency optimizer technology that minimizes power consumption to the lowest practical level. This technology allows designers to use any DC-to-DC



The 6th (Shanghai) International Road Lamp, Patio Lamp & Outdoor Lighting Fair (RLF2011)

Date: Sep. 21st– 23rd, 2011

Venue: Shanghai World Expo Theme Pavilion

Concurrent events:

The 2nd (Shanghai) International LED Interior Lighting Fair 2011

Shanghai Chandelier Lighting & Decorative Lighting Fair 2011

Shanghai Energy Saving Lamp Fair (SESLF 2011)

The 3rd China Public Lighting Summit 2011



Organizing Committee Contact:
Guangzhou Grandeur Exhibition Services Co., Ltd
Add: Room 802B, Jiayue Building, No. 38 of Zhongshan Mid Avenue,
Tianhe District, Guangzhou, China 510660
Phone: (+86)20-2896 9899 Fax: (+86) 20-8257 9220
Person: Moon Zhong (Miss) Email:sales8@grandeurhk.com
Mobile:(+86)15914321437 Website: <http://www.rlof.com>

or AC-to-DC converter topology with isolated or non-isolated implementation, while dynamically maintaining the highest system power efficiency by minimizing excess voltage across LED strings.

The Atmel drivers enable LCD TVs to achieve an ultra-high 10M:1 dynamic contrast and the lowest motion-blur. The new drivers also provide over 10,000:1 pulse-width modulation (PWM) dimming range for PC monitors and industrial displays. In solid state lighting applications, the new LED driver ICs and Atmel microcontrollers allow dynamic white-point setting, color-mixing and networked lighting with Zigbee, DALI and other standards. Other features include comprehensive fault management, LED aging and thermal control, and programmability with the on-chip EEPROM and scalability to any number of LED strings with minimal DC-to-DC converters.

"LED lighting applications are the future of the LED driver ICs market, forecast to grow above 35% per annum until at least 2016," said Mitess Nandha, analyst, IMS Research. "We are expecting the residential and outdoor markets to have the most significant gains, while office and commercial indoor are also growing strongly. In these emerging markets, barriers to entry are still low and suppliers who offer drivers with increased efficiency, higher intelligence and more functionality have the chance to grow swiftly. Atmel has the opportunity to become a key player with their latest offering of flexible LED drivers for both lighting and backlighting."

"Atmel is excited to enter some of the fastest growing segments in the semiconductor industry," said Tushar Dhayagude, marketing director of smart power products at Atmel Corporation. "Increasing LED adoption in LCD panels and lighting creates a tremendous opportunity for Atmel to leverage its industry-leading microcontroller architectures to push the envelope on efficiency, programmability, simplicity and solution cost."

The multi-string Atmel LED driver ICs are available in three categories including external MOSFET current sinks for high-power LED lighting and edge backlighting applications; internal MOSFET current sinks for direct backlighting and low-power LED lighting; and with integrated power controller for PC monitors and industrial, medical, military displays. ■

Phihong's New High-Quality AC-DC LED Drivers for OEMs

Phihong, a global leader in power solutions, has developed a series of lighting power supplies for LED luminaire applications in both indoor and outdoor environments. The constant-current and constant voltage drivers are worldwide-compatible with high line and low line AC input voltage ranges and provide standard dimming on all outdoor models.

"The overall focus of the lighting industry is changing to encourage more economical and environmentally responsible alternatives to current applications," said Keith Hopwood, vice president of marketing for Phihong USA. "By leveraging our experience in electronic ballast production and energy-efficient product design, we see powering LED lighting as a natural progression for Phihong to expand its existing lighting business."

The line-up includes models for indoor use in small-footprint plastic housings with ingress protection ratings that meet IP20 specifications; they are ideal for applications that include small string lighting or a few high-intensity bulbs especially for display lighting, recessed kitchen lighting and emergency exit signs. All indoor models are constant-current, available in 350 mA or 700 mA outputs and provide 5.6 W up to 30 W of power. A selection of these LED power supplies will also be available in halogen-free options and will therefore not give off toxic smoke in the event of a fire.

Outdoor models are rated IP65 in full isolated potted metal casings and have dimming as a standard feature. Currently available are 30 W-50 W multi-channel, constant-current



Phihong introduces its new series of drivers for indoor LED lighting

drivers with 0-10 V dimming and a single-output, constant-current 10W driver with triac dimming. A 75 W constant-voltage model with standard 0-10 V dimming will be available soon. Applications for water-resistant power drivers include outdoor signs, street lighting, architectural designs and automotive lighting.

Additionally a 90 W open-frame model introduced in 2010 is available in a constant-voltage output of 24 V DC for easy integration into luminaires for street/area lighting or traffic lighting.

Standard features on all LED drivers include over-voltage, over-current, short-circuit and open-circuit protections as well as brownout/brownout recovery. Wide temperature ranges allow for a diverse array of applications for end users. ■

Philips New Xitanium Re-Programmable LED Driver

Philips Lighting announces the newly developed Xitanium Programmable LED driver for all outdoor LED lighting applications. This driver offers a unique level of flexibility, with a large number of features which can be customized for an optimal solution in each and every luminaire design. The highly reliable technology will set new global standards for outdoor LED lighting solutions.



The new Xitanium Programmable LED driver offers full design flexibility, quicker time-to-market and simplified logistics management

For luminaire manufacturers, the Xitanium Programmable LED driver offers full design flexibility, quicker time-to-market and simplified logistics management. A wide output current range makes the driver future-proof in preparation for LED efficacy upgrades.

For the end users the driver offers "Xtreme" outdoor specifications, ensuring reliability and long life of the luminaire. The 1-10 V interface allows for simplified, one-way management, while the DALI protocol makes any installation with the Xitanium Programmable LED driver ready for a fully networked control system, meeting the growing demand for professionalization of municipal services. Even without an external control system, the Constant Light Output feature and the integrated Dynadimmer functionality deliver additional energy savings and CO₂ reductions. ■

ENCELIUM Introduced POLARIS 3D™

Encelium Technologies, an innovative leader in energy management and lighting control systems, has introduced Polaris 3D, its next generation of lighting control software for the Energy Control System™. As the first software application of its kind in the lighting control industry, Encelium elected to unveil this ground-breaking technology at Lightfair International 2011, held in Philadelphia this spring.

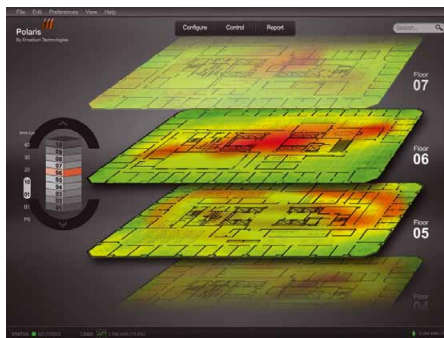

Polaris 3D

The new software, which will be available in August, offers users a single 360°, three-dimensional navigation in a multi-floor view, permitting faster and easier navigation to a desired control zone with the ability to see an entire facility or complex in a convenient 3D snapshot.

"Polaris 3D is a unique lighting innovation with tremendous capabilities," explained Terry Mocherniak, chief operating officer of Encelium Technologies. "Users will no longer need to navigate through single floors, or 'tree architecture' to control

lighting in their facility. Instead, they now have all of the key data at a glance, enabling them to optimize energy savings and improve occupant comfort and productivity with ease."

Utilizing Microsoft's Silverlight technology, Polaris 3D will permit access to the system via a simple web browser, eliminating the need for software installation, resulting in increased security, faster set-up and start times, and easier integration with other web-based building control systems. Polaris 3D also provides a colorized thermo-graphic representation of system parameters for lighting status, power consumption, light levels; occupancy status; load shedding status; and comparative energy trends.

"As a result, users will be able to identify lighting related inefficiency trends or operational anomalies anywhere in the facility," Mocherniak said. "Such non-lighting parameters as temperature, CO₂ levels, and air quality can also be represented in this thermo-graphic view, if the system is integrated with a building automation system."

The central software enables facility managers with drag and drop functionality to simply group floors, rooms or even desks into zones, which are then controlled as a unit. Users can instantly rearrange lighting layouts by moving a zone from one area to the other with just a click of their mouse. Polaris 3D also provides the ability to change light levels anywhere in a complex, modify default levels and set lighting time schedules.

The launch of Polaris 3D follows Encelium's recent introduction of its CarbonWatch energy dashboard software application. Working with the company's Energy Control System, CarbonWatch continuously displays a building's energy performance and carbon footprint reduction in a slide-show format. Designed for public information displays in building common areas, it can also be installed in interactive information kiosks. ■

Perfection & competence

LED heatsinks from

fischer

elektronik

- versatile product range of LED heatsinks, excellent thermal geometries for natural or forced convection
- special profiles, customised machining and modifications for your specific application



Extruded profiles

compatible for all established LED-types, case profiles with integrated guide grooves

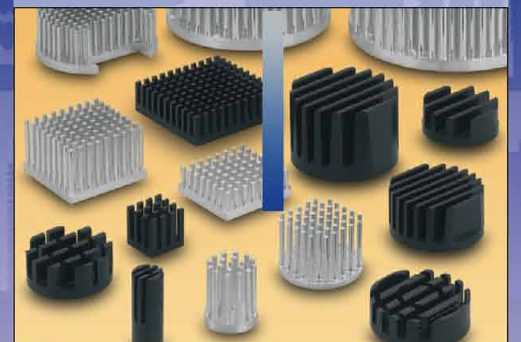

Round and pin heatsinks

aerodynamic omnidirectional fin geometry, flat LED mounting area, low weight



Customised LED heatsinks

competence in "Thermal Management" for LEDs, in-house measuring lab for thermal analysis

P. O. Box 1590 D-58465 Lüdenschied
 Nottebohmstraße 28 D-58511 Lüdenschied
 Tel. +49 23 51 4 35-0 Fax +49 23 51 4 57 54
 info@fischerelektronik.de
 www.fischerelektronik.de

Cases
 Heatsinks
 Connectors

OLED: Record-Breaking Efficiency News from Osram - 87 lm/W

Technological breakthrough at OSRAM: researchers and developers have achieved a new efficiency record in the laboratory for OLED. The laboratory sample achieves 87 lm/W, significantly exceeding the current peak value. And the most important thing: the laboratory sample is highly proximate to the product, thus paving the way for highly energy-efficient OLED products with considerably higher brightness.

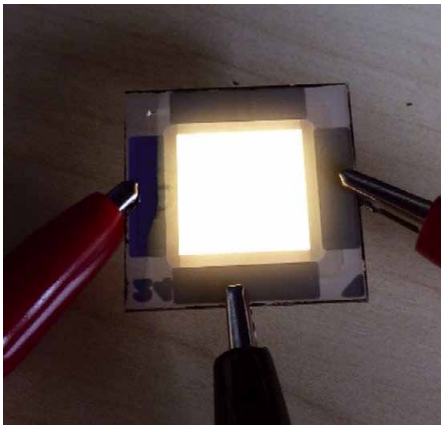

OLED laboratory-sample from Osram

In its research process OSRAM has taken a major step closer to its goal of developing mass-market OLEDs. The current laboratory sample achieves 87 lm/W – exceeding the previously-achieved peak value by 40 percent. This means that OLEDs are almost achieving the efficiency of fluorescent lamps in the laboratory. Important: measurement is performed under application-oriented conditions in an integrating sphere – that is, without macro extractors, i.e. lenses to optimize the measurement results. Measurements were taken at a brightness of 1,000 cd/m² and a color temperature of approximately 4,000 K. A further success for the OSRAM research team: the laboratory sample also achieved almost 75 lm/W at a brightness of 5,000 cd/m². The organic functional material employed was already tested in pilot manufacturing and enables product-relevant lifetimes.

The OLED laboratory sample was prepared using a pure thin-film approach. The current was distributed evenly over the active surface using a special injection electrode on the light-generating surface and offers homogenous light density from every angle. The aesthetic impression is not disrupted by visible electrode structures. The manufacture of the sample is highly product-proximate – plans for industrialization are already being evaluated.

"We have made a key breakthrough with the laboratory sample. For the first time we have managed to obtain such high efficiency whilst retaining both aesthetic and technological characteristics such as lifetime, robustness and extreme flatness in a thin-film approach – in other words, we have given the panel the characteristics that are also central for future series production," says Thomas Dobbertin, head of OLED technology at OSRAM.

OLED research at OSRAM is funded via the TOPAS 2012 project of the German Federal Ministry of Education and Research (reference no. 13N10474). The focus of the research work of TOPAS 2012 is upon the development of OLED as the lighting of the future. "With our new peak value we have taken a major step towards our goal of achieving 100 lm/W," says Thomas Dobbertin. ■



Nactus 101 Optical System

Khatod, a front-runner in Lighting Solutions, is proud to unveil NACTUS 101, the most revolutionary optical system offering the most advanced innovation in Wide Area Lighting.

NACTUS 101 continues on the way of new-concept, ready-to-use optical modules developed by Khatod; conceived for Power LEDs of latest generation; realized in many multi-lens arrays, from 6 to 24 – 36 – 48 optics and over; more than a hundred configurations from stock; patented technology and innovative design for any WAL applications.

Come see for yourself!!
Visit us at LED Professional Symposium + Exhibition – Sept.27-29, 2011



150°

Discover the first power LED duo
with sophisticated beam angles.

80°

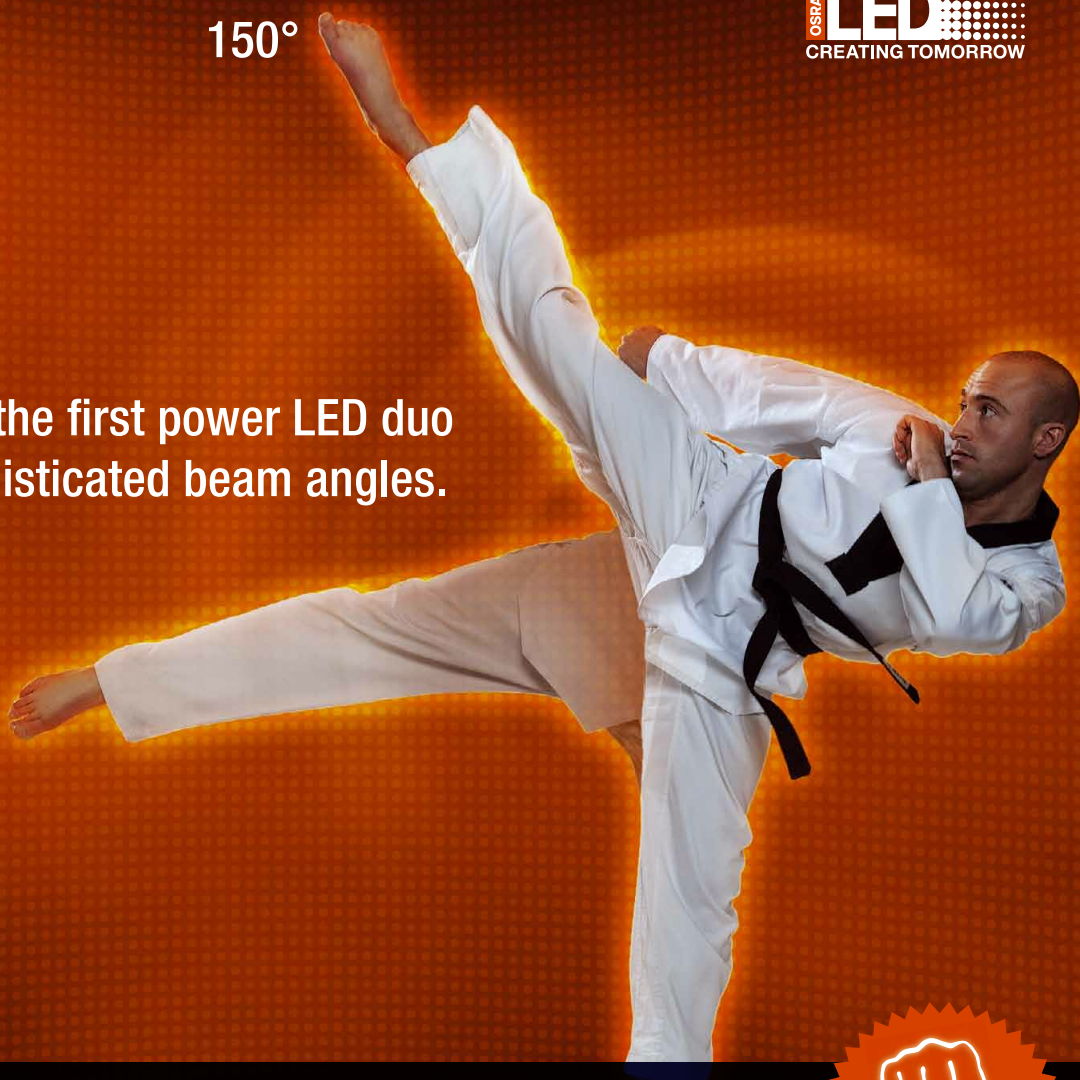

ORDER YOUR
FREE SAMPLE
ONLINE!

OSLON® SSL 80 and 150

These remarkably compact LEDs offer beam angles optimized for use with lenses and reflectors. This revolutionary feature, combined with a broad range of color temperatures and color rendering indexes, open up new possibilities for cost-effective and efficient lighting solutions – for any application you want.



OSRAM
Opto Semiconductors

Insights Into Recent LED Developments

LED professional interviewed Eric Virey, a leading LED expert at Yole Développement, about LED technology and market trends. He explained how LEDs are designed today and what we can expect in the next few years in terms of efficiency and costs.

LED professional: What are the current research topics in the field of LEDs?

Eric Virey: The internal quantum efficiency has been improved significantly for the most part, thanks to the improvements of the different chip layers. More recently, the major improvement we have seen is the development of the wafer bonding and substrate removal process like laser lift off. This has allowed the wide spread adoption of the vertical structures where the epitaxial substrate, sapphire or silicon carbide, is completely removed and replaced by another substrate to which it is bonded. This substrate can be a semiconductor, like germanium, silicon or a metal like copper or a copper tungsten alloy.

This allows for an LED chip with much better thermal properties. This means you can drive it harder and extract more light from it.

The only limitation for this technology is still the IP because some companies own strong intellectual properties. It was initially adopted by Osram, then Lumileds and Cree and it was certainly part of some patent licensing agreements. Other companies like Semileds have also developed IP and products relative to those structures.

LED professional: That's really an advantage and shows a lot of progress. What about the thermal expansion coefficients of these different layer materials, though?

Eric Virey: This is why, for example, I think Osram uses germanium, which has a very good match with gallium-nitride (GaN). What I've also seen for the metal substrate is the use of a sinter substrate with different compositions that allows for tuning the thermal expansion coefficients for a better match to Gallium-Nitride.

LED professional: Could you give us a rough idea about where the losses in an LED come from?

Eric Virey: Currently the internal quantum efficiency is about 80%, which is pretty good. The target is to get about 90% in accordance with the DoE roadmap for GaN LEDs. For Gallium-Arsenide (GaAs) based LEDs, Indium, and InGaP LEDs we are talking about 75%. A lot of photons are also generated but they never escape the chip. Therefore light extraction is still a key topic. Light extraction efficiency is at about 86%. In total we have about 60% efficiency - in other words 40% of the energy is transformed to heat.

LED professional: What about the phosphor losses based on the Stokes law? How important is this factor? We have heard values between 70-80% - Is this correct?

Eric Virey: Typically the phosphor quantum yield at room temperature is about 80%. But the problem is that you lose 10-15% more at higher temperatures, which is one of the reasons of using remote phosphor.

LED professional: If we take all these losses into account we end up roughly with about a 50% loss rate. But if we take the datasheet values of actual LEDs with, let's say, 100lm/W for a warm-white LED and compare this to the theoretical maximum figure it would be less than 50%. Isn't there a gap between both calculations?

Eric Virey: There is no agreement in industry about the theoretical maximum. Keep in mind that it strongly depends on the CRI (Color Rendering Index) you need to achieve. But values of about 250lm/W with >80 CRI will be feasible for commercially available products on a long term view.

LED professional: Let's get back to the topic of phosphor. How do you see remote phosphor concepts in general?

Eric Virey: The idea is not new. The Rensselaer Polytechnic Institute (RPI) first investigated it some years ago. It started to be adopted at the luminaire level by the companies like Nexxus Lighting and from the packaged LED level by GE. With the introduction of the CromaLit products from Intematix we will see more and more remote phosphor products entering the market. There are multiple benefits. The first one is avoiding thermal overheating due to the separation and if you couple this concept with a well-designed optical cavity that recycles the backscattered photons you can clearly improve the overall efficiency of your system. Another benefit for the luminaire or system

Table 1:
Updated LED targets 2011
(Source: DOE SSL Manufacturing Workshop 04-2011 Boston)-table

Metric	Unit	2010	2012	2015	2020
LED Efficacy (2580-3710K, 80-90 CRI)	lm/W	95	133	179	211
LED Pkg Price (warm)	\$/klm	18	7.5	2.2	1
LED Efficacy (4746-7040K, 70-80 CRI)	lm/W	133	166	197	215
LED Pkg Price (cool)	\$/klm	13	6	2	1
OEM Lamp Price \$/klm	\$/klm	50	16	10	5

manufacturer is that he can order just the phosphor plates and match it with his own production line.

LED professional: Philips started the remote phosphor in the Fortimo module several years ago. Did you also observe their product strategy?

Eric Virey: The Fortimo is still available and still using remote phosphor technology. Their Endura LED bulbs are also using phosphor-coated designs and at the LED level, Philips Lumileds are offering the Lumiramic product portfolio where a ceramic based phosphor is attached to the chip. So this is not a remote phosphor but it significantly improves the color homogeneity. Another interesting thing is that remote phosphor can also speed-up the adoption of quantum-dot technology because it's more sensitive to temperature, in general.

LED professional: With regards to costs Silicon-based LED chips are also being discussed. What do you think about this trend, so far?

Eric Virey: The benefit is definitely costs and not performance. We have been talking about blue LEDs on silicon since at least 2002. A company in Japan, Sanken Electric, has been

announcing a Silicon-based LED for many years but their products are essentially limited to low power LEDs. There are still a lot of challenges for bringing the costs down and overcoming design and production obstacles. The technology is doable but it is not at the stage where it is cost-effective and friendly. At the end of the day, it's a matter of cost of ownership: will the extra manufacturing steps needed to make good GaN on Si with high yield still allow to beat the cost of existing sapphire based LED or not. I really can't say if it will ever succeed. The longer it takes, the more sapphire based structures will improve and the more difficult it will be – it's like a moving target that can never be accomplished. Of course there are significant programs going on at, for example, Lumileds, Osram, Lattice Power, Bridgelux, Azzuro or IMEC. But you also have to keep in mind that the substrate only accounts for about 5% of the overall costs of an LED.

LED professional: Do Silicon-based LEDs also mean that it might be possible to integrate more complexity into an LED like an LED driver?

Eric Virey: In this case we are talking about wafer-level packaging where the Silicon substrate is used not for the

epitaxy but for the packaging. This means you take a large and thick substrate and you etch a cavity where a pick-and-place machine places the LED chip inside. What we have seen so far in term of integration is some manufacturers like LG adding the ESD protection onto the substrate based on this technology. There are research projects going on for the integration of more complexity, such as drivers or controls, using wafer-level packaging technology.

LED professional: This brings us back to Bridgelux. They recently announced that they will have the Silicon-based LED ready to sell in two years. Are you skeptical about this time-frame?

Eric-Virey: Not skeptical, just cautious because I've heard the same thing from other companies many years ago. That said, if I were a sapphire maker, I would definitely keep an eye on their progress!

LED professional: You also said that the costs of the substrate are only 5% of an LED in total. What are the other cost factors, then?

Eric-Virey: Yes, the substrate is more or less 5%. The packaging is about 40-50%. Depending on the type of phosphor and package, this part can be significant. The epitaxy cost is at least 20% and strongly depends on the yield. Today most LED manufacturers throw away more than 50% of the die they manufacture.

LED professional: If the package has such a high cost influence, then chip-on-board systems should have a clear advantage. How do you see COB technology?

Eric Virey: Yes, COB has the potential for cost reduction and also performance improvement because of the reduced thermal path. We will definitely see more and more adoption of COB technology, especially for very high-power and high-brightness packages, whether they are made from arrays of small chips or very large chips. Citizen or Sharp is offering these solutions. Edison, Lextar and even CREE also recently introduced COB

Figure 1:
Projected LED package cost track
(Source: DOE, preliminary data provided by the Cost Modelling Working Group)

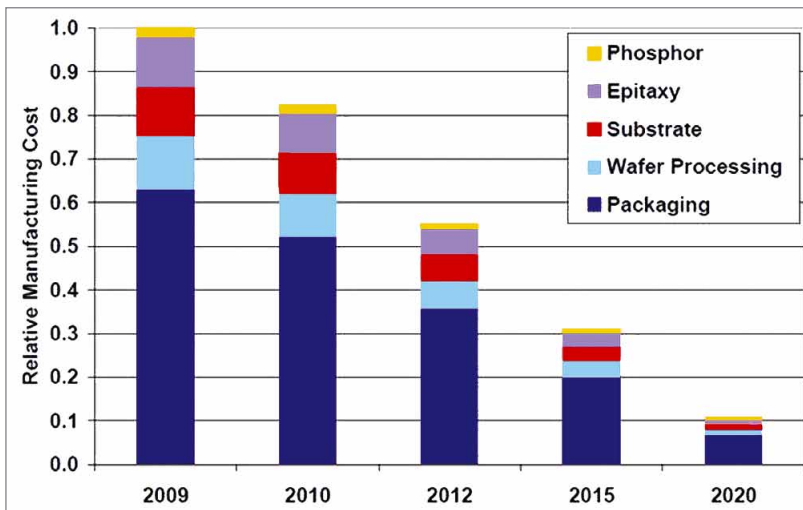

products. Luminus Devices are using what I call “Jumbo Chips”. These are very large dies that they mount with COB technology.

LED professional: Could a quality problem be the reason why the COB technology is not commonly used, especially in regards to the globe being dispensed?

Eric Virey: I don’t know exactly what the limitations of COB technology are. Thermal expansion is certainly a topic which includes the differences in thermal expansion between the GaN chip and the metal-core board. We also have COB technology mounted directly on ceramics which would reduce this problem.

LED professional: Coming back to the subject of costs: How big of an influence is the wafer-size on the costs of the final LED product?

Eric Virey: Using a larger diameter is an incentive. The first benefit is the improvement of the MOVCD throughput. For example, for the Aixtron G5, if you go from a 2-inch to a 4-inch wafer you increase your total substrate surface per run by 10%, and

if you go from 2-inches to 6-inches you increase this figure by 48%. In terms of trends, the majority is still 2-inch but we are seeing a transition to 4-inch wafers. Some technology leaders, like Osram, have been using 4-inch wafers for years.

LED professional: The production of larger wafers is more costly. Is there an optimum wafer-sized wafer in regards to the costs?

Eric Virey: Increasing the diameter of the sapphire manufactured is a challenge. It becomes more and more difficult to extract. The first generation of crystal-growth machines was able to produce 25-32 kg crystals. State-of-the art systems are now producing very good quality 75-100 kg crystals.

LED professional: The costs are still high - also when looking at the LED replacement lamps. How can we expect the costs to come down over the next few years?

Eric Virey: One way of looking at this is the total-cost of ownership (TCO), considering how much energy is used and how long it lasts. So if you look at

the TCO, in many applications LEDs are already superior to any other light source. But the upfront cost is still a major barrier for adoption. The industry agrees that we still need a factor of about 10 in cost reduction (expressed in Dollar per Lumen).

LED professional: What about the time frame for reaching this target?

Eric Virey: In the latest DoE roadmap which is the result of the industry consensus, they are going beyond the targeting factor of a 10-20 reduction at the packaged LED level, expressed in Dollar per Lumen, between 2010 and 2020. Again, this is a kind of industry consensus. I believe it is doable but not in one step. It has to be a combination of economy of scale, improvement in yields, processing, manufacturing efficiency, and of course, technology with new materials. All that combined makes that roadmap quite achievable. It’s not easy but it is reasonable.

LED professional: Let’s come back to technology. The droop effect is something people are working hard to improve. Where we are at the moment?

Figure 2: Evolution of socket occupancy by technology (base scenario), Source: Yole Développement & EPIC

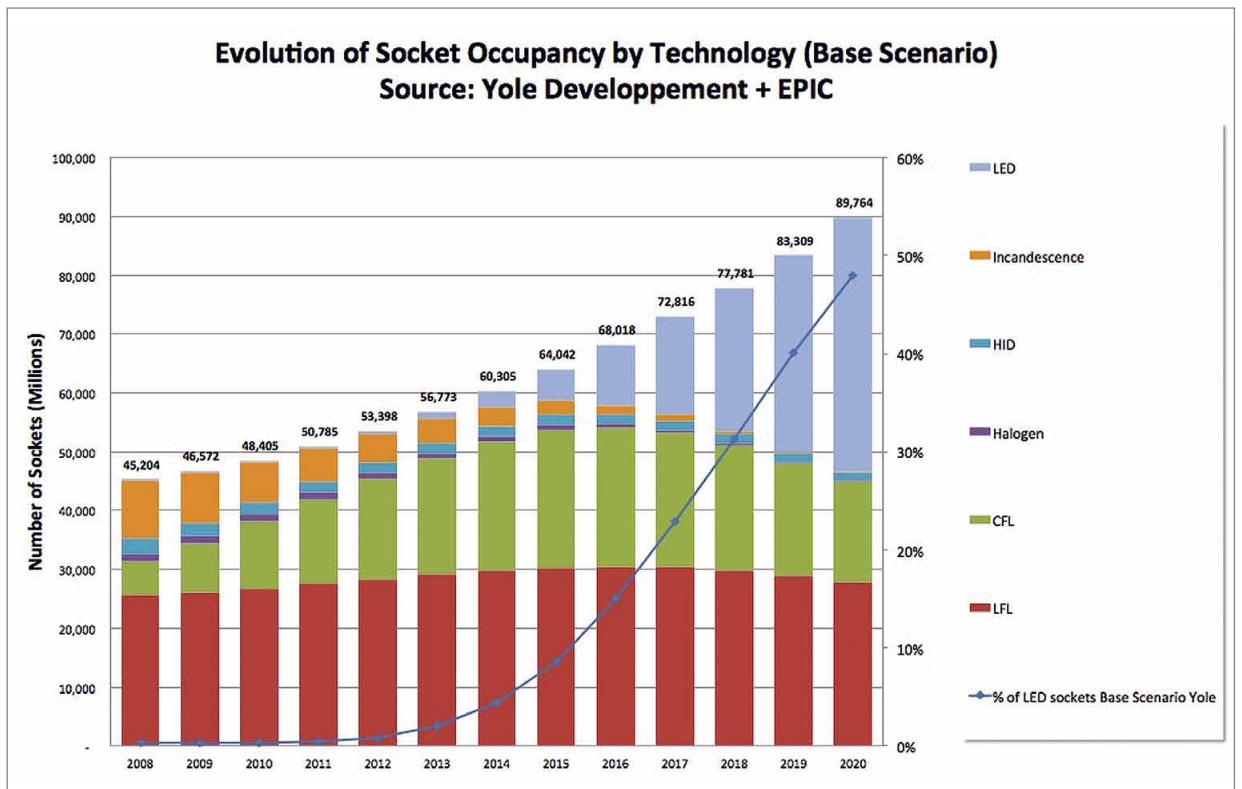

Eric Virey: The research results still don't agree about the source of the droop effect. There have been various explanations like the Auger recombination and some others. What I found interesting is that each of these explanations can be translated into an improvement on the LED chip level. For example, for the Auger recombination you make larger quantum wells. When you apply these improvements each of them seems to improve the droop a little bit but not solve it completely.

If we look at the fundamental research, the RPI recently published a statement saying that the existing LED model, the so-called ABC model, that describes the behavior of the electric bulk carrier in an LED has three different types of recombination. They are saying now that this model might be not sufficient and that we might need a fourth type of recombination to account for the droop effect. On the other end UCSB again claim that they have solved and understood the droop effect and they are adamant that it is the Auger recombination effect. So these two groups don't seem to agree. I guess it will take a few years before it is fully understood. It's possible that in the end it will be improved significantly but not fully eliminated.

LED professional: As you know LED professional focuses mainly on Solid-State Lighting. How do you see the market trends in the field of LED lighting?

Eric Virey: Generally speaking, if we look at the big picture, I am extremely optimistic in the adoption of LEDs for general lighting applications. You can't look at general lighting just as bulb application; there are a lot of different market segments. Each of them has its own technology requirements and market drivers, I would say that adoption for each of those sub-segments takes place at a different time and space. In some applications, like street lighting, the customer is very sensitive to the TCO. So for those applications there is already a strong incentive to adopt LEDs. For other applications, where the customer tends to buy depending on the price in a supermarket, we have to reduce the initial cost further. In general, energy efficiency will become the number one target next to the cost issue.

LED professional: What about the market volumes for LED bulbs?

Eric Virey: Our model and forecast for 2011 is still below 1% in term of socket occupation (how many light sockets currently have an LED source in place). In terms of volume of lamps that are sold, I'm expecting about 2% in 2011 but growing up to 40% in 2015.

LED professional: Thank you very much for your insights on LEDs!

Eric Virey: Thank you. ■



Eric Virey, Ph.D.

In the last 12 years, Eric has held various R&D, engineering, manufacturing and marketing positions with Saint-Gobain. Most recently, he was Market Manager at Saint-Gobain Crystals, in charge of Sapphire substrates and materials for the optical fiber telecoms market. He worked with senior corporate management and across multiple business units as a market and technology evangelist to identify and develop new business opportunities in the field of energy efficient lighting. Eric has collaborated with Yole since 2009. He has contributed to and co-authored multiple reports and studies on LED materials and applications including the "LED Mantech", "Status of the LED Industry" and "Sapphire" reports. Eric Virey holds a Ph.D. in Optoelectronics from the National Polytechnic Institute of Grenoble.

Growing GaN Epi Layers on 200 mm Silicon Substrates for LED Applications

Current LED manufacturing is primarily based on GaN-on-sapphire technology on 50 mm and 100 mm sapphire substrates. However, before LEDs can be widely used for general lighting applications, a real breakthrough is needed to significantly lower manufacturing costs. Kai Cheng and Johan Dekoster from imec Belgium with Sung Won Jun and Jose-Ignacio Del-Agua-Borniquel from Applied Materials, Inc. explain the actual status of a disruptive approach to accomplishing this, the use of GaN on low cost 200 mm silicon (Si) wafers.

Over the last several years, LEDs based on gallium nitride (GaN) have proven to be very effective devices due to their high robustness, excellent lifetime, reduced energy consumption and fast response. These properties have made them the preferred candidate for the next generation of solid state lighting for both residential and commercial applications. The LEDs are fabricated on GaN layers that are grown hetero-epitaxially on foreign substrates since bulk GaN substrates are too expensive for high-volume LED manufacturing. The pioneering work was done on sapphire substrates and today the LED industry fabricates GaN-based LEDs predominantly on 50 mm and 100 mm sapphire substrates.

State-of-the art UV and blue LEDs on 100mm sapphire substrates have shown impressive performance with internal quantum efficiencies of ~70% and extraction efficiencies as high as 85%. However, a few hurdles need to be overcome before LEDs can compete with existing lighting technologies. Degraded efficiency at high current injection, also known as the efficiency droop, is one of them.

Regardless of technical issues, a cost reduction of 4 to 5 times below current levels is needed before LEDs can be widely used in general lighting applications.

A Technology Platform for GaN-on-Si Manufacturing

One approach to cost reduction is boosting manufacturing productivity by growing GaN film layers on larger diameter wafers. Sapphire wafers are becoming available in 150 mm, but their surface quality is still inadequate and they are costly. Using the same Si wafers to make semiconductor chips is a very attractive alternative since they are much less costly, have tight quality control and are widely available in 200 mm. In addition, the use of Si substrates allows GaN LEDs to be manufactured in the same wafer fab on equipment that leverages imec and Applied Materials' vast experience gained from developing and supporting tools used for 200 mm CMOS production. GaN LED manufacturing can benefit from state-of-the-art CMOS fab practices, which feature fully-automated tools operating in 24/7 mode, maintain strict process and particle control, and benefit from ongoing hardware and process support. In addition, the

availability of in-situ metrology and accelerated lifetime testing facilitates the production of highly reliable devices. Therefore, one can achieve lower costs by leveraging the economies of scale and the knowledge gained from Si wafer manufacturing.

Other advantages of Si substrates over sapphire wafers are silicon's higher thermal conductivity, lower defect density, and reduced thickness, which makes them easier to handle.

LEDs have already been made on 100 mm Si wafers, demonstrating the feasibility of the technology. However, growing GaN on 200 mm Si presents several challenges. The thermal and lattice mismatch between GaN and Si generates stress in the film during growth, resulting in a large wafer bow. This effect is more severe when the wafer size increases. The stress can lead to local variations in the performance of the LEDs within one single wafer, and even to cracking and delamination of the GaN epitaxial stack. Recently some progress has been achieved on stress engineering and growth optimization of a GaN epitaxial stack on 200 mm Si wafers. These results largely contribute to the realization of cost-effective high brightness UV and blue LEDs.

Table 1:
By introducing a DC grid energy saving opportunities in various applications are given

Figure 1:
Different layers
of the GaN-based
LED stack



A GaN-based LED Stack

The envisaged layer stack, deposited on a Si(111) substrate consists of an AlN template, AlGaIn intermediate layers, an undoped GaN layer, an n-type GaN layer, InGaIn/GaN multiple quantum wells (MQWs) and finally a p-type GaN layer (Figure 1). The preferential growth technology for the nitrides is metal-organic chemical vapor deposition (MOCVD), the proven method for mass production. The resulting device performance, wavelength uniformity and yield are strongly linked to the performance of the MOCVD processing chamber(s). The results presented here have been obtained by using a cluster tool developed by Applied Materials. The advantage of using a cluster tool configuration is having dedicated chambers for those process steps in which effects such as cross-contamination can degrade device performance. In our MOCVD processing chambers, the process temperatures are in the range of 400°C to 1150°C and the growth pressure varies from 15 to 300 Torr.

The AlN Nucleation Layer

The first layer, which is grown directly on the Si substrate, is an AlN nucleation layer. This layer is required because of the poor wetting properties of GaN on Si and due to melt-back surface effects that create crater defects due to the corrosive nature of Ga on Si. Therefore, optimizing the AlN growth process to obtain excellent AlN layer quality and repeatability is a first

key step in achieving high-quality GaN layers. In-situ chamber clean is performed between AlN layer processes. A thorough study of the growth conditions – the ratio of the precursor's trimethylaluminum (for Al) and ammonia (for N), growth pressure and growth temperature – resulted in the best-known-method recipe for the AlN growth: high temperature at low pressure and with low ammonia (NH₃) flow. With this recipe, AlN layers can be grown with good crystalline quality (as measured by rocking curve high-resolution x-ray diffraction (HR-XRD)) and surface morphology. The latter was evaluated by atomic force microscopy (AFM) and values were shown to be among the best reported in literature. In addition to the growth parameters, it was found that the proper MOCVD processing chamber conditioning is essential. After preventative chamber maintenance, the AlN crystal quality and surface roughness of the wafers improved as a certain number of runs were repeated highlighting the importance of chamber seasoning. Our first experiments also point towards a positive effect of an in-situ chamber clean as part of this seasoning process.

Stress engineering

Although good AlN crystal quality is achieved, which is essential for the next GaN growth, the lattice and thermal mismatch between AlN and Si induces tensile stress on the AlN film, resulting in a negative wafer bow. When growing an undoped GaN (u-GaN) layer directly on top of this template, the u-GaN layer also exhibits a negative bow indicating tensile stress again that worsens with increased layer thickness. When the u-GaN layer thickness is increased to more than 1 μm, the GaN film will crack due to the stress. In order to grow thicker, crack-free GaN films, a 200 nm AlGaIn (50% Al) intermediate layer has been introduced that induces compressive stress and thus counterbalances the thermal tensile stress in the AlN film. An u-GaN of 1 μm thickness on top of this AlGaIn intermediate layer now shows large compressive stress (wafer bow of +120 μm). By increasing the u-GaN layer thickness to 2.3 μm, the GaN layer becomes slightly tensile again and the wafer bow is reduced to -15 μm, which is appropriate for further wafer and device processing. This sample showed a very smooth surface, shown in Figure 4 (root mean square roughness ≈ 0.3 nm). A threading dislocation density (TDD) of

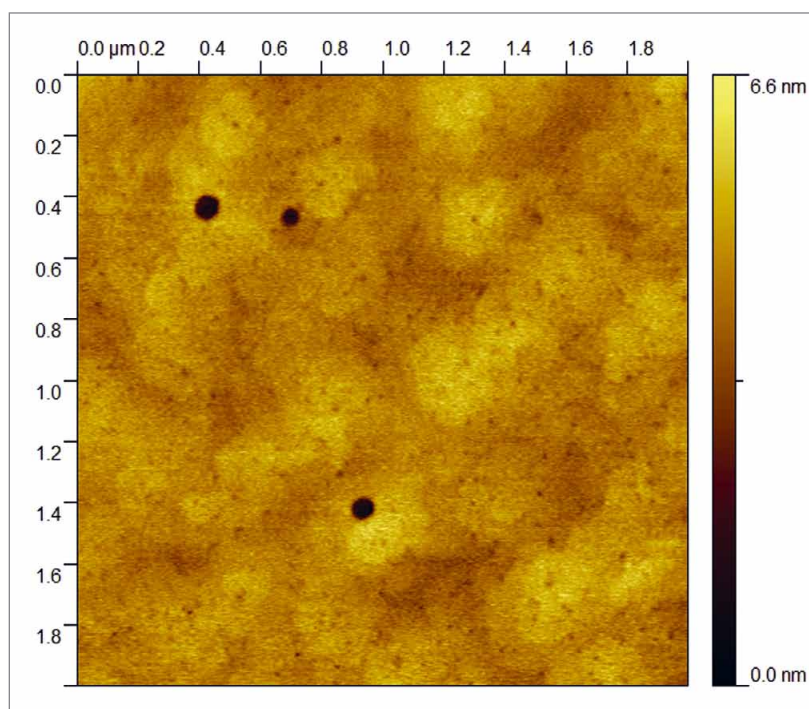
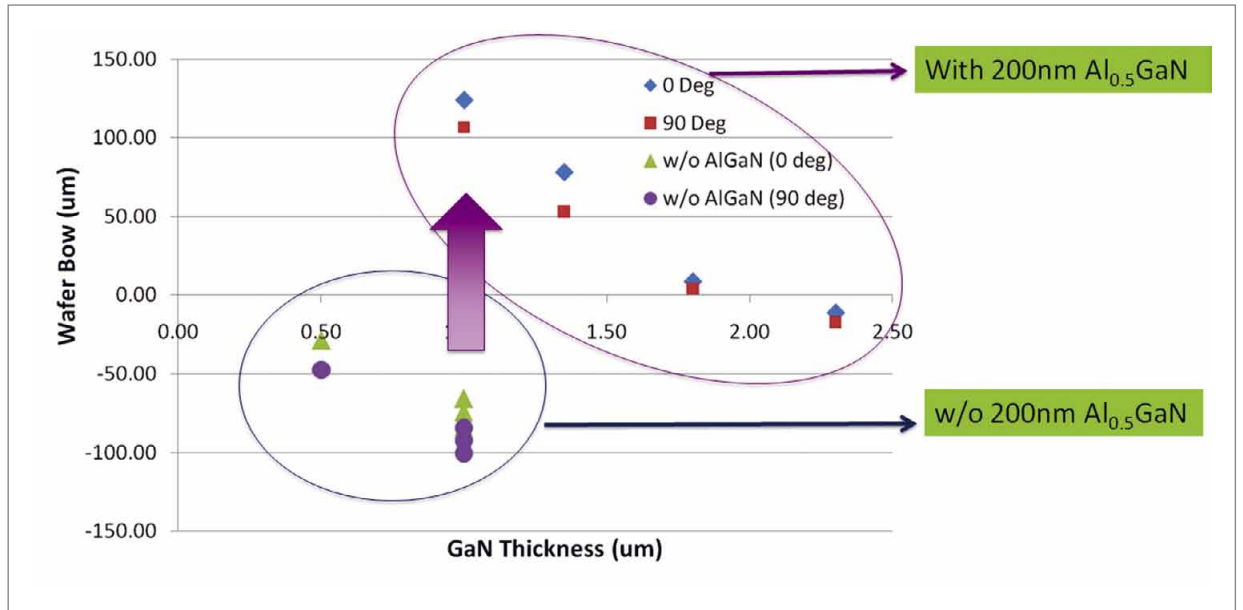

Figure 2: Surface morphology of AlN layers grown with 2SLM NH₃

Figure 3:
Wafer bow changes to positive upon introduction of the AlGaN intermediate layer



$2.5 \times 10^9 \text{ cm}^{-3}$ was observed by plan view TEM, but most dislocations are terminated at the interface between GaN and AlGaN.

These results indicate that stress engineering makes it possible to deposit GaN layers of more than 2 μm thickness on 200 mm Si and to maintain the wafer bow below the critical value to allow successful follow-on processing of the wafer into devices.

Growing Si-doped n-GaN Layers

The knowledge obtained from u-GaN layer growth was then applied to growing Si-doped n-GaN layers. The Si doping level is controlled by adjusting the Si_2H_6 flow during GaN growth. While the influence of Si doping on the crystalline quality was observed to be minor, the wafer bow is significantly influenced by the Si doping level: by increasing the Si doping from $1 \times 10^{17} \text{ cm}^{-3}$ to $4.5 \times 10^{18} \text{ cm}^{-3}$, the wafer bow changed

from +70 μm (compressive) to -6 μm (tensile) because of more pronounced compressive stress relaxation.

The electrical properties have been characterized by Van der Pauw Hall measurements. With the highest Si doping level, the electron mobility exceeds $200 \text{ cm}^2/\text{Vs}$ with an electron density of $4.5 \times 10^{18} \text{ cm}^{-3}$. This result is comparable to n-type GaN grown on sapphire and is an important contributor to final device performance.

Figure 4:
GaN RMS roughness of 0.3 nm in a $5 \times 5 \mu\text{m}^2$ scan area

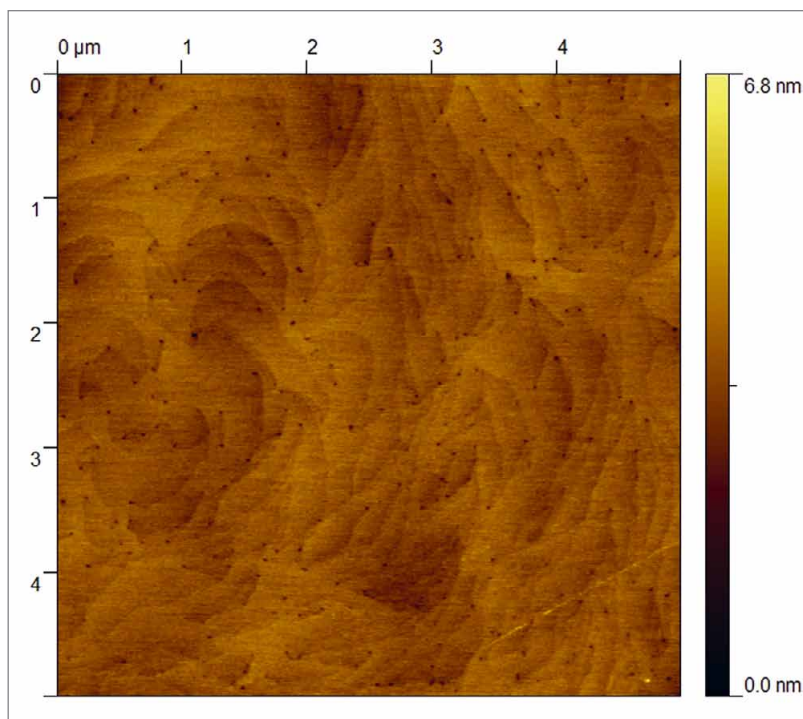

As is shown in the previous session, compressive stress relaxation can be prevented by adding more AlGaN intermediate layers. In addition to the single $\text{Al}_{0.5}\text{GaN}$ intermediate layer structure, a triple layer structure consisting of 400 nm $\text{Al}_{0.75}\text{GaN}$ / 400 nm $\text{Al}_{0.5}\text{GaN}$ / 400 nm $\text{Al}_{0.25}\text{GaN}$ was also used to further increase the crack-free n-GaN layer thickness. It is feasible to grow $\geq 2.5 \mu\text{m}$ n-GaN with a Si-doping level of $4.5 \times 10^{18} \text{ cm}^{-3}$. The crystalline quality of n-GaN layers is also improved by growing thicker layers. The best sample shows a TDD of $1.5 \times 10^9 / \text{cm}^2$.

Another series of experiments highlighted the need for further n-GaN optimization: photoluminescence (PL) spectra showed strong yellow luminescence from n-GaN layers grown at 1050°C , caused by deep

MBI6902

Step-down, High Efficiency, Non-isolated AC/DC LED Controller

- Accept universal AC input from 80VAC to 265VAC
- Hysteretic PFM improves efficiency at light loading Efficiency = 90% @ VAC =110V, 350mA, 6-LEDs
- Setting current accuracy within $\pm 5\%$
- To drive external MOSFET current up to few Amperes
- Full protection: Thermal/UVLO/OVP/LED Open-/Short- Circuit
- Available package: MSOP-8L

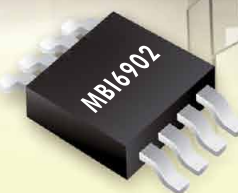

Applications:

- T-8 CFL Replacement LED Solution
- E27
- PAR30
- Power Supply for Light Panel
- Other LED lighting

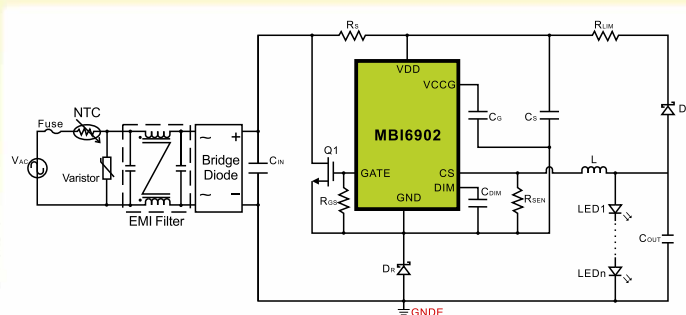

2011 LED Symposium in China

Date and Venue:

Jul.19, Kempinski Hotel, Beijing

Jul.21, Nikkos hotel, Shanghai

Jul.25-26, Shangri-La Hotel, Shenzhen

Tel: +886-3-579-0068 • Fax: +886-3-579-8934

Website: www.mblock.com.tw • Email: marketing@mblock.com.tw

traps in the buffer layer. It was demonstrated that the growth temperature of the underlying u-GaN and n-GaN layers plays a significant role. When growing these layers at a slightly higher temperature, the crystal quality improves and in the meantime, the carbon background in n-GaN is also measured less than $1 \times 10^{17}/\text{cm}^3$, shown in Figure 7, well into the

acceptable range. Thus, the yellow luminescence is strongly reduced because of the lower defect density in n-GaN layers.

This n-type GaN buffer layers can subsequently be used as a template for growing multiple quantum wells (MQWs) and p-type GaN on top.

MQW Active Region and p-GaN Layers: Preliminary Results

The active region of the LED stack consists of InGaN/GaN multiple quantum wells. In order to obtain uniform and repeatable growth, the MQWs are grown in a dedicated chamber of the Applied cluster tool. Initial data showed an average PL wavelength of 450 nm obtained on a 200 mm Si wafer. The MQW growth recipe was transferred unchanged from one optimized on sapphire and resulted in an internal quantum efficiency exceeding 40% with GaN on Si. The active region has been characterized by cross section TEM, which shows excellent interface quality shown in Figure 6. This encouraging result proves the feasibility of growing high efficiency LEDs on 200 mm silicon. More work is ongoing to increase the IQE above 60% in order to compete with the state-of-the-art LEDs fabricated on sapphire substrates.

Figure 5:
Cross section
TEM of the active
region

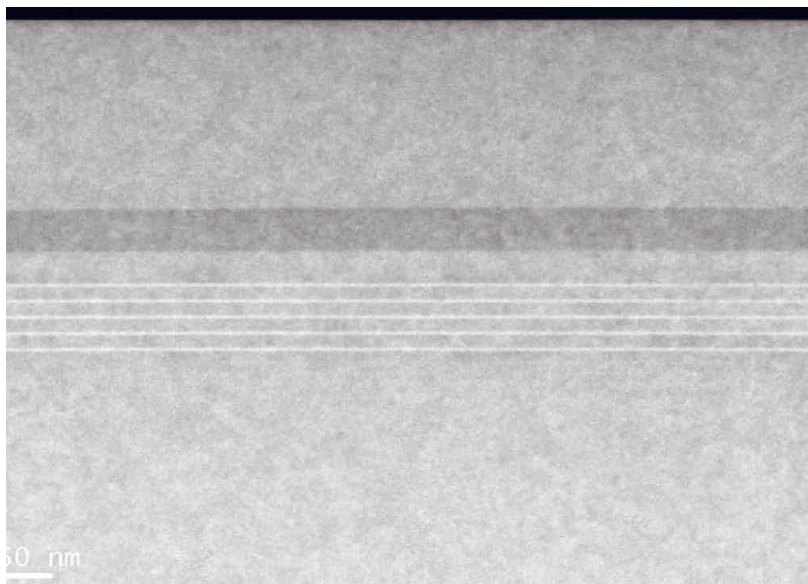
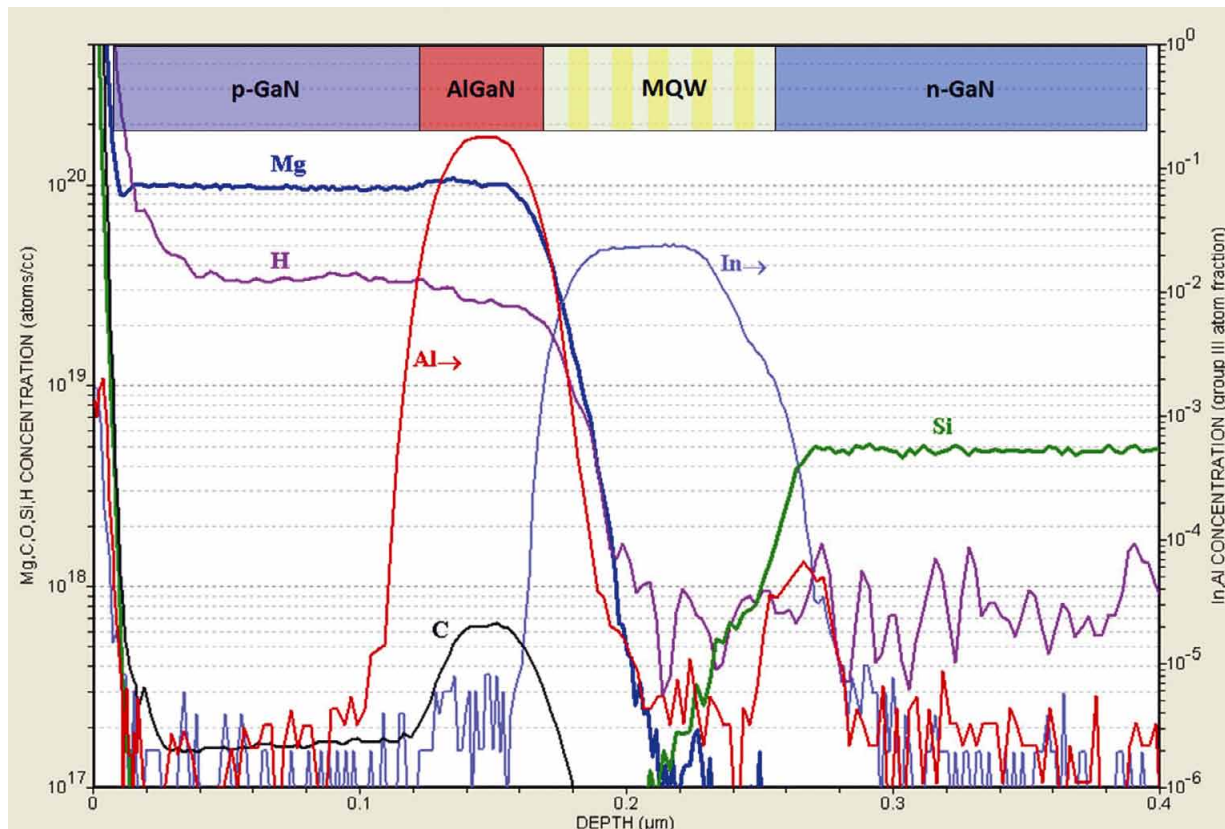

Figure 6:
SIMS profile of
LED on 200 mm Si



The properties of the final p-type GaN layer are also optimized by employing a dedicated chamber conditioned with Mg. The Mg-coated chamber is helpful to achieve efficient Mg incorporation. The chemical composition has been analyzed by secondary ion mass spectrometry (SIMS), shown in Figure 6. The Mg concentration in the top p-GaN layer is over $1 \times 10^{20}/\text{cm}^3$ while the carbon background is reduced to the order of $1 \times 10^{17}/\text{cm}^3$. Thanks to the high Mg doping level and low impurity background, the threshold voltage of an LED fabricated on a Si substrate can be as low as 3.2 V.

Conclusion

GaN-on-Si is moving towards becoming a cost-effective enabler for next-generation LED devices. This requires the development of GaN epitaxy on large-diameter (200 mm) Si substrates, which also brings important technical challenges. One of the main issues stems from the large thermal and lattice mismatch between GaN and Si, making it difficult to grow GaN epi layers on the Si substrate. The growth of high-quality GaN layers on 200 mm Si (111) wafers using a cluster tool was explored and optimized to tackle this challenge. The first key step is the epitaxy of high quality AlN

nucleation layers to circumvent the Si/Ga etch-melt effects. A best-known-method recipe for AlN growth is proposed and the importance of chamber conditioning is established. Next, the introduction of an AlGaIn intermediate layer allowed us to control the wafer bow of a subsequently deposited u-GaN layer. With this knowledge, the basic steps have been set to grow thick (2.5 μm) Si-doped n-type GaN layers with comparable electrical characteristics as n-GaN on sapphire. This n-GaN template is the starting point for further active layer (MQW) and p-GaN development. ■

Acknowledgements:

The results presented here have been obtained in a joint development program between imec and Applied Materials. Imec further tackles these challenges in its industrial affiliation program (IIAP) on GaN LED devices, together with its program partners. This IIAP builds on imec's excellent track record in GaN epilayer growth.

The authors would like to acknowledge Hu Liang, Maarten Rosmeulen, Vasyi Motsnyi, Celso Cavaco, Paola Favia for support with XRD, bow, PL, IQE, Hall and TEM measurements.

Your partner for lighting components, lighting management systems and LED modules

TRIDONIC

▼ enlightening your ideas

We can do a lot for your light.

Impressive solutions for your LED products.



The LED Solution Box from Tridonic is a versatile package that helps you find the solution you want – components, light modules, systems and renowned Tridonic service. With Tridonic, you have everything under control, whether you choose conventional or LED lighting. **We devote all our energy to your light.**

led.tridonic.com



Influence of the Phosphor Selection on Lighting Quality

Dan O'Hare and Jonathan H. Melman, Ph.D. from Intematix talk about how choosing the appropriate phosphor or remote phosphor component can improve the light quality, efficacy and thermal stability of an LED system.

Phosphor creates the user experience of LED light and as such, selecting the appropriate phosphor is crucial to the success of the application. Phosphor, a luminescent material that absorbs light of one wavelength and emits light at another wavelength, is responsible for 95 percent of visible lumens from a white LED. The remaining 5 percent comes from the blue chip itself. Breakthroughs, after many years of research and development by lighting materials leader Intematix, have introduced improved phosphor materials as well as patented remote phosphor products, which make a phosphor component the main light source of the system. Taking these updates into consideration, we will outline the major characteristics to consider when optimizing your LED system.

Phosphor Materials

Phosphors used in both remote phosphor sources and local phosphor single and array LEDs include those from the main categories shown in

Most applications require temperature stability so that the color characteristics and conversion efficiencies remain constant over hours of use at operating temperatures. The specific application will help guide phosphor selection; for example, high power/high brightness situations generally mean higher operating temperatures, which would favor phosphors with high temperature stability. Materials with low thermal stability are suitable in low and medium power applications. Spectral characteristics also play a key role in phosphor selection. For example, in wide color gamut display applications, aside from specific color points to enable covering a large area of color space, a narrow peak shape enables all photons generated to pass through the display color filters and provide high system brightness. In low color gamut display applications, such as lower end mobile, a single phosphor with a wide emission peak able to create a cooler CCT white (i.e. CIE 1931 $x = 0.300$, $y = 0.300$) is suitable. For general illumination purposes, a broader emission peak in the green or yellow enables higher CRI. However, a narrow emission peak is generally more advantageous for

red, as the red output contributes little to the total lumen count of the system but is vital to achieve high system CRI and warmer color temperatures (Figure 1). There are many other applications, each of which have their own specific requirements.

Even the most thermally stable phosphors show some reduction in emission peak intensity with increased temperature during bulk powder testing. For example, cerium doped yttrium aluminum garnet (YAG) -- often considered the gold standard of the industry -- shows a five percent decrease in output when the temperature changes from 20°C to 100°C, while a silicate phosphor with a similar color point might show a ten percent decrease. The differences are more marked when examining the changes from 20°C to 150°C -- a ten percent decrease for the YAG, but as much as thirty-five percent for the silicate. Such decreases result from a reduced population of ground state electrons, which would normally provide the excited state light output transitions, and an increase in non-emission decay paths. The temperature of the phosphor will be increased above ambient by several means, the primary of which is the LED itself, but the phosphor contributes to the heat of the system through quantum efficiency losses and the down-conversion process: the energy lost to the Stoke's shift manifests itself as heat.

Table 1:
Temperature stability and conversion characteristics

Phosphor Material	Temperature Stability	Spectral Characteristics
Silicates	Low	Narrow
GAL	High	Broad
YAG	High	Broad
Nitrides	High	Narrow
Sulfides	Variable	Narrow
Q dots	Low	Narrow

Figure 1:
LED emission spectra comparison of a Wide Color Gamut display, and low and high CRI general illumination outlines how the requirements are different

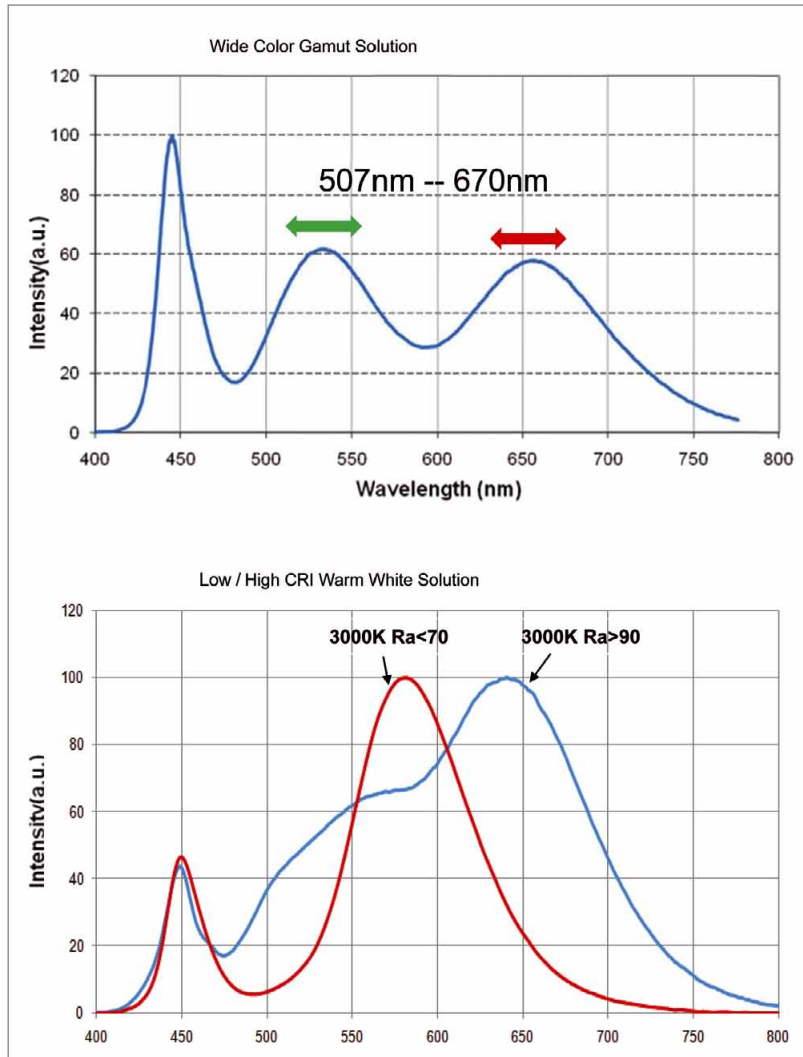

In a remote phosphor configuration, the LED chip is less of a direct heat source, though the incident LED spectral flux, quantum efficiency losses, and the down-conversion process still generate heat. While phosphor performance characteristics can be measured across a broad range of values, it is important to also remember that other materials may have performance limitations that must be considered; for example, polycarbonates often used as substrates for remote phosphor components are usually limited to 100°C. Many high power applications would have a higher temperature to consider in the design process of a traditionally packaged LED, but the same light output in a remote phosphor configuration can run substantially cooler, enabling use of materials which would not have been selected in a traditional configuration.

For even higher output systems, remote phosphor on glass substrates enable the operating temperature to run about 150°C, which keep the phosphor selection criteria similar to that of the traditional high power LED.

Remote Phosphor Features

The remote phosphor architecture removes the down-converting phosphor layer from the LED device and places it on a two-dimensional or three-dimensional component external to the LED. Several benefits of using a remote phosphor light source include operation of the phosphor at a reduced temperature to improve life and conversion efficacy, improvement of light extraction from the LED system and reduction of thermal loading on the LED.

To efficiently utilize the improved extraction of light from the remote phosphor system, an efficient, highly reflective mixing chamber is required (Figure 2). The mixing chamber integrates the down-converted light producing, in combination with the remote phosphor, an extremely uniform Lambertian source at the remote phosphor surface. This beam is spatially and spectrally mixed and provides glare-free light.

Note that in most designs, the remote phosphor has very little conduction cooling. The predominant methods of heat transfer are convection and radiation. The diagram below (Figure 3) shows a typical thermal balance for a 61.5 mm diameter 2D configuration at 30°C ambient with 12 total DC watts LED power (6 watts of blue power incident on the remote phosphor). The model assumes no conduction cooling of the remote phosphor through the mounting structure.

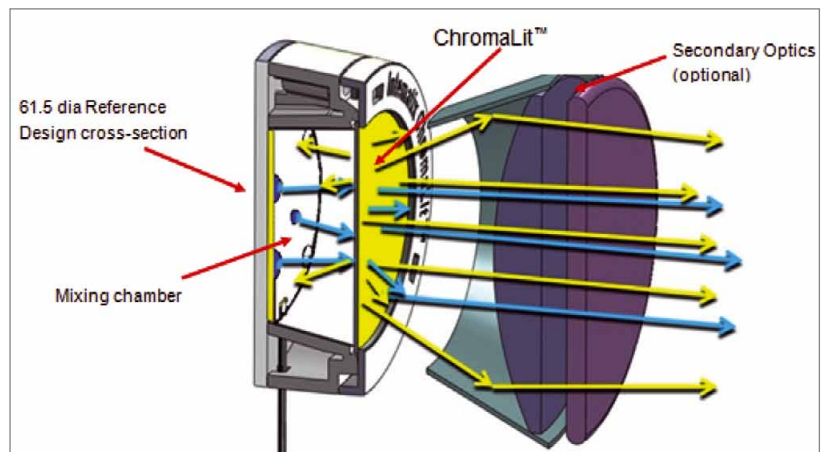
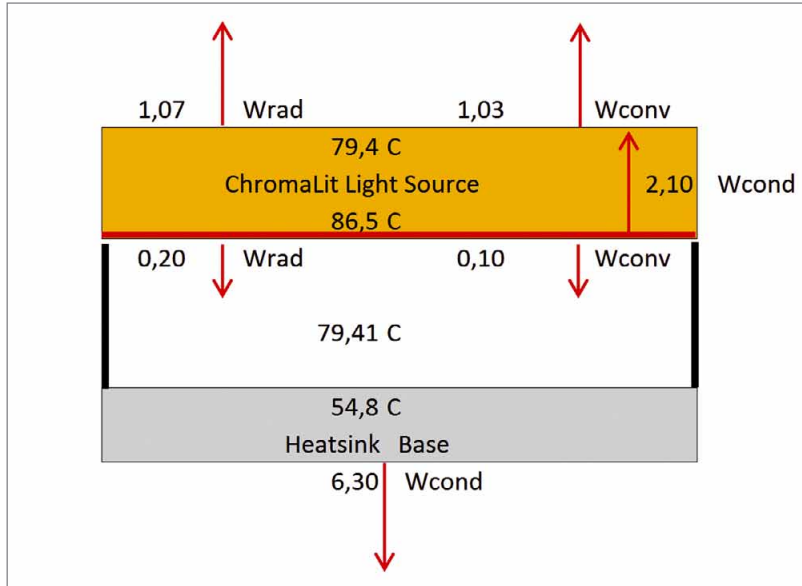

Figure 2: LED rays – blue, down converted rays - yellow

Figure 3:
Thermal Balance



phosphor. No diffuser is required with the remote phosphor configuration since the output beam is properly mixed and uniformly distributed by the mixing chamber and remote phosphor source. The LEDs in both cases are surrounded by a highly reflective mixing chamber and all white LEDs provide 3,000 K nominal operating correlated color temperature and are compared to the blue LED combined with 3,000 K ChromaLit™ remote phosphor. Figure 5 below, shows that the beam angle of the white LED downlight is significantly broad to lend itself to a remote phosphor configuration (beam angle >60°).

Application Considerations

Because the remote phosphor produces a low glare, highly diffuse Lambertian radiation pattern, it is particularly well suited to general lighting applications. These include downlights (wide beam angle), high bay, task, linear, and panel lighting. Although these comprise a great number of lighting applications, phosphor formulations for saturated colors are also possible, such as those for signal, warning, and vehicle back lights.

Remote phosphor also allows LED luminaire manufacturers to tune the intensity distribution by engineering a 3-dimensional phosphor component to guide light in different ways. The graphs below (Figure 4) illustrate sample distribution patterns. Using phosphor components to tune light distribution enables applications such as PAR lamps, lanterns, and A-19 retrofit bulbs.

Nonetheless, applications that require a directional light source like spot lighting are more suited for a white LED architecture. Remote phosphor can improve many systems, but it is not the proper solution for all projects.

Case Study – Downlight White LED versus Remote Phosphor

Traditional LED down lights use white LEDs in combination with a diffuser. A performance comparison for LED down lights using a blue LED pump with a ChromaLit™ remote phosphor source was performed and the resulting improvements in system efficacy are presented here.

The comparison utilizes the downlight luminaire design shown in Figure 7. White LEDs with local phosphor and diffuser are compared to equivalently powered blue LEDs with remote

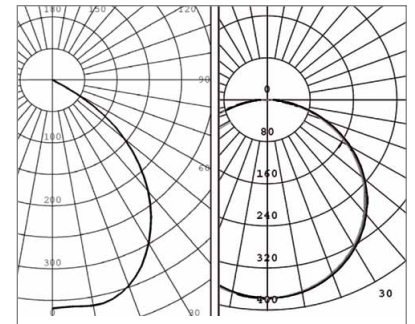

Figure 5: Beam Angle for White LED (left) vs Remote Phosphor Downlight (right)

Description of Test

Source LED's were selected for drive currents of 1,000mA. Total electrical DC power ranged from 17.45 watts to 20.38 watts. The LED's were assembled into a down light fixture as shown below. All tests were performed using the mixing chamber shown in Figure 6a.

Figure 4:
Examples of intensity distribution using preliminary data from Candle, Chromalit Core and Sphere shapes. Artist rendering of A-19 retrofit below

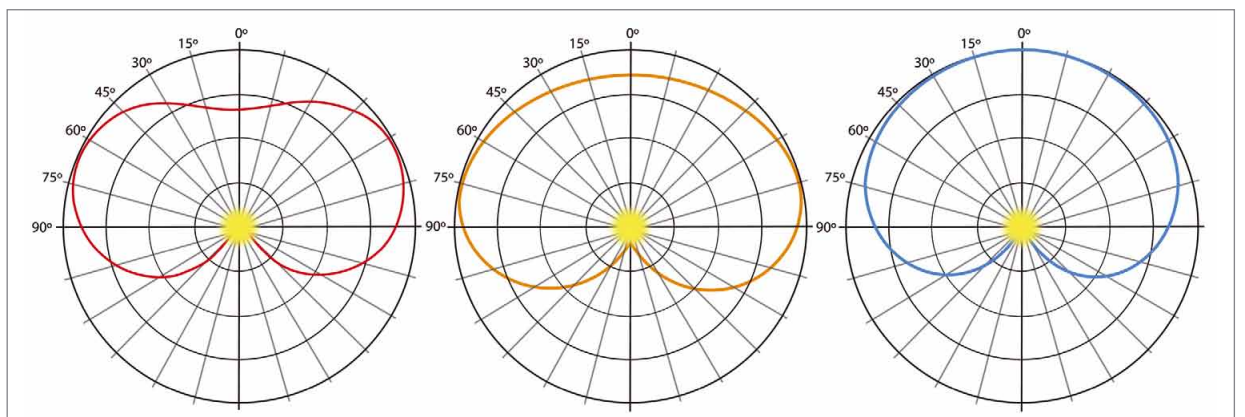

Figure 6:
 (a) Mounted LED showing highly reflective mixing chamber. (b) White LED assembly with white LED and diffuser. (c) Complete remote phosphor Assembly. (d) Complete white LED and diffuser

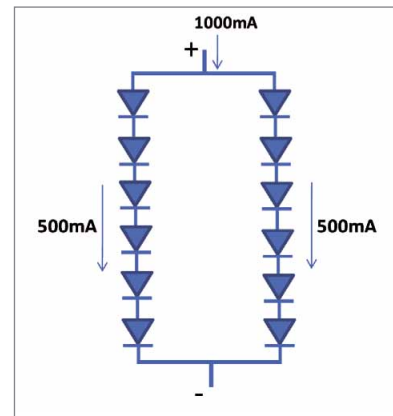
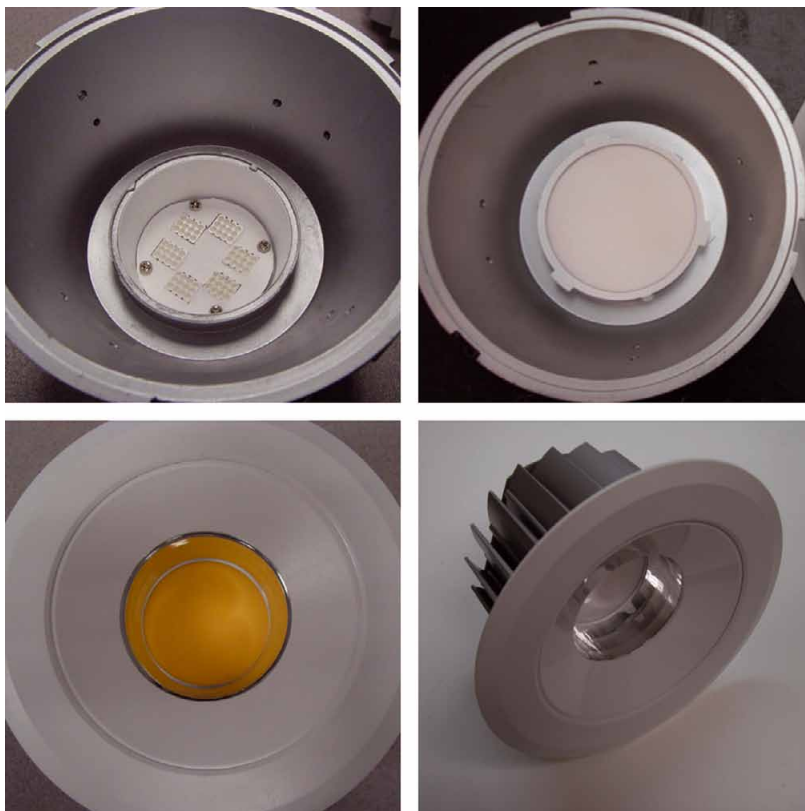

Figure 7: All units were powered using a DC power supply set to 1000mA

The white LED assembly contains a diffuser to provide equivalently distributed light as is achieved with the ChromaLit remote phosphor configuration. The test sources are all mounted as shown below (Figure 8) in the 1.5 meter integrating sphere.

Figure 8:
 (a) 1.5 meter integrating sphere. (b) Mounted down light in sphere



For each design, the down light is mounted in a 1.5 meter integrating sphere with the source pointing down. Each test unit is driven at identical constant current, and lumens are obtained instantaneously as well as

after a 1.5 hour thermal stabilization. The total DC voltage and forward current are recorded for each test and lumens per electrical DC watts (lm/eW) are derived using the measured luminous flux and input power.

Performance Data Comparison for White LED and Remote Phosphor Downlight

The remote phosphor system produces 30% increase in lumens per DC watt for pulse test (no warm up) and 35 % for the thermally stabilized case.

The graph below (Figure 9) shows relative total luminous flux for a remote phosphor downlight using ChromaLit™ remote phosphor. The output after 6,000 hours has not degraded more than 3% with a phosphor surface temperature of 85°C. This data supports the improved thermal characteristics of the remote phosphor architecture.

Table 2:
Test Data Summary

(1) LPW is not optimized for this relative output comparison test. Downlight reflective baffle reduces LPW 10%. ChromaLit phosphor source conversion efficiencies have been improved over 10% since these measurements were made

LED Manufacturer	blue/white	Warm Time (hrs)	Lumens	CRI	DC watts	Lumens/DC watt (1)	% improvement
A	blue	0	1070	80.1	19.27	55.53	32%
A	white	0	796.3	80.2	18.99	41.93	
A	blue	1.5	1021	79.3	18.69	54.61	35%
A	white	1.5	744.5	80.2	18.43	40.39	
B	blue	0	1020	80.3	18.49	55.19	36%
B	white	0	767	80.5	18.85	40.69	
B	blue	1.5	1021	79.3	18.14	56.30	41%
B	white	1.5	738	80.4	18.51	39.86	

New products of LED Controller Series



Mini RGB LED Controller

Specification:
 Input Voltage: 12/24V DC.
 Output channel: three channels of RGB.
 Output Current: 4A for each channel
 Output Power: 144W (12V input) / 288W(24V input)

Special feature:

* Compatible with all common RGB strips and low voltage RGB lamps, Built-in 16 modes and can be controlled by a small key board. Automatically adapt to LED light which works at DC12V/DC24V. Hardware PWM dimmer without any flashes. High-power MOS driver, the whole current of the RGB three channels reaches to 12A. Compatible with WC12 also.



4 in 1 LED Controller

Specification:
 Input voltage: DC12/24V
 Output current: 4A/channel (total 5 channels)
 Output channel: 5 (R,G,B,W,WW)
 Remote frequency: 433MHz
 Control distance: >30m (open space)

Special feature:

* Can be switched to three different working modes: RGB and RGBW+WW and WWW.
 * Can be adapted to any LED product which need a controller for operation.



Dimmable Rotary Knob RGB Controller

Specification:
 Input voltage: DC12/24V
 Output current: 6A/channel (total 3 channels)
 Output channel: 3 (R, G, B,)
 Remote frequency: 433MHz
 Control distance: >30m (open space)

Special feature:

* Three rotary knobs enable RGB unlimited dimming up to 1024 levels, easy for operation.

Figure 9:
 Total luminous flux for remote phosphor downlight

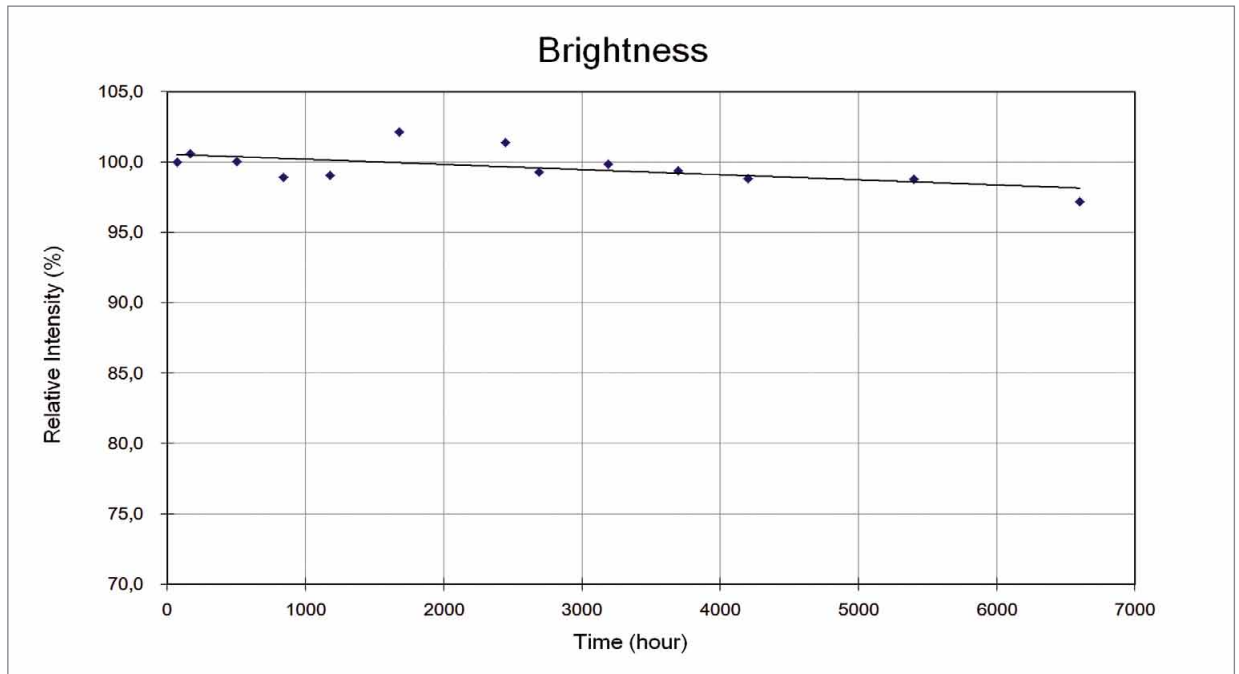

Conclusion

Phosphor is a significant factor in LED performance, but even more importantly, phosphor is a significant factor in user acceptance of LED based lighting. Improvements in phosphor technology over the past few years have made a large impact on the

segments accessible by LED based illumination, as evidenced by the acceleration of LED based lighting and LED based display. Phosphor choice can determine the success or failure of an LED in the particular application, and placing the phosphor remotely can further optimize certain systems.

The choice of the correct phosphor material based on system requirements such as color, color rendering and anticipated thermal parameters is an important step in the design process and properly done can give the designer bright prospects for success. ■

LED Light Fair LED+Light Tech Show

香港國際LED應用照明科技展 **Hong Kong**

- **26-29 October 2011**
- Kowloonbay International Trade & Exhibition Centre



3rd LED Light Fair/LED Light Tech Show will take place during Oct. 26-29, 2011 at Kowloonbay International Trade & Exhibition Centre, with a space totaling 9,000 square meters. Take hold of the precious occasion and meet face-to-face top-notch LED lighting buyers from around the world, thereby extending your reach in the international and Asia-Pacific market.

3rd LED Light Fair/LED Light Tech Show 2011 is an international professional exhibition for buyers for LED products, construction engineering, design/architecture, photovoltaic, wind power, water resources, water technology, and environmental protection/energy conservation.

Major exhibit categories:

1. Green lighting
2. Outdoor lighting
3. Interior lighting
4. Photovoltaic lighting
5. LED lighting applications
6. Sophisticated residential lighting fixtures
7. Avant-garde commercial-lighting fixtures
8. LED illumination technology and related components/parts

Organized by D & A Int'l Corp., LED Light Fair/LED Light Show is a professional show focusing entirely on products related to LED lighting, construction and engineering, design, architecture, and environmental protection/energy conservation. LED Light Fair/LED Light Tech Show 2010, the second edition of the show, attracted 8,835 buyers from 88 countries or areas, including Taiwan, Hong Kong, and Macao.

www.ledlightfair.com



LED Light Fair
Show
LED+Light Tech
香港國際LED應用照明科技展

Contacts

+886 2 2649 4888

info@ledlightfair.com

Highly Efficient and Reliable Power Supply for LED Street Lighting

In several lighting applications, especially street lighting, LEDs are the preferable lightsource because of their efficiency, longevity, robustness and reliability. Other components have to keep the pace with this performance. Wonseok Kang and Sungmo Young from Fairchild Semiconductor had a close look on resonant power converters and explain the differences between using standard MOSFETs or the latest High-End counterparts.

LEDs provide high efficiency and long life compared to conventional lighting sources. Therefore, they are becoming the first priority of lamp types to reduce energy consumption for internal or external lighting. This is also the case in street lightings where better efficiency and longer life are essential for less cost. A switching power supply designed to power up LED lamps should also have high efficiency and robustness to assure a maintenance free lifetime, as long as the LED lamp.

Resonant converters are one of the most popular power supply topologies here since their performance delivers increased power efficiency and reduces EMI compared to previous power supply topologies. Soft switching is an important feature of resonant converters. But the use of the body diode in resonant converters sometimes leads to system failures. The stored charge in body diodes should be completely removed to avoid high current and voltage spikes including high dv/dt and di/dt in these topologies. Therefore, critical parameters of power MOSFETs such as Q_{rr} , and reverse recovery dv/dt directly affect the dynamic performance of resonant converters.

This article will explore a total solution for a switching power supply targeted to LED street lighting. A new resonant controller combined with a new power switch enable a high efficiency solution for the LED lighting power supply which doesn't sacrifice the robustness and cost effectiveness of the converter.

Resonant Converters for High Efficiency

Several DC-DC power conversion topologies have been introduced to reduce switching losses, device stresses on the power MOSFETs and radio frequency interference (RFI) while achieving high power density. Among them, resonant converters, which utilize body diode of MOSFETs for zero voltage switching, are proven to be very effective for higher efficiency. In particular, an LLC resonant converter can achieve high efficiency at high input voltage and low voltage stress on a secondary rectifier since there is no inductor on the secondary. In addition, the LLC resonant converter can guarantee zero voltage switching (ZVS) operation even at no load. The ZVS technique dramatically reduces the switching losses and significantly improves efficiency. The zero voltage switching also reduces the switching noise noticeably, which allows a small

sized electromagnetic interference filter. Because of these unique characteristics, LLC resonant converters are becoming a popular topology for many applications including LED street lighting. FAN7621S offers everything necessary to build a reliable and robust LLC resonant converter. It simplifies designs and improves productivity by including a high-side gate drive circuit, an accurate current controlled oscillator, frequency limit circuit, soft start, and built-in protection functions. The various protection functions it provides are over voltage and over current protections (OVP/OCP), abnormal over current protection (AOCP), and internal thermal shutdown (TSD). All protections are auto-restart because of the particular application requirement of LED street lighting. The high-side gate drive circuit has a common mode noise cancellation capability that guarantees stable operation with excellent noise immunity. Even with the latest resonant controller, the converter operating point moves into zero current switching (ZCS) region under shorted output conditions. Figure 1 shows how an operating point moves. During this condition, ZVS is lost and the MOSFET conducts extremely high current. The most severe drawback of ZCS operation is hard switching at turn-on

Figure 1:
Operating Points of LLC Resonant Converter according to load condition

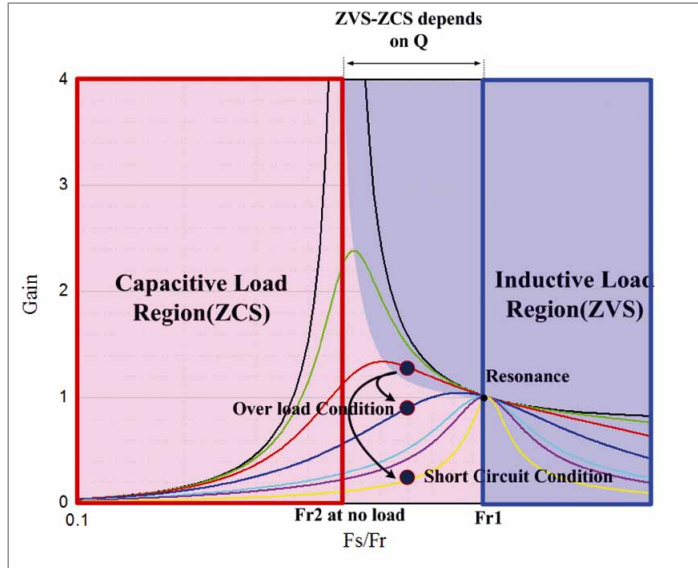

that leads to MOSFET body diode reverse recovery stress. The body diode turns off at a very large dv/dt and therefore, at a very large di/dt , generates a high reverse-recovery current spike. These spikes can be over ten times higher than the magnitude of the steady-state current. This high current causes considerable increase in losses and heats up the MOSFET. Then, dv/dt capability of MOSFET is degraded due to the temperature rise in the junction. In extreme cases, it may destroy the MOSFET and cause system failure.

The Latest MOSFET Technology

The body diode of MOSFETs typically has a very long reverse recovery time and large reverse recovery charge. In spite of its poor performance, the body diode has been utilized as a freewheeling diode because it can make a simple circuit without adding system cost in some applications such as resonant converters. As more and more applications use an intrinsic body diode as the critical component in the system, Fairchild designed a

new highly optimized power MOSFET for resonant converters with deep analysis of MOSFET failure mechanisms. It has improved body diode ruggedness and less stored energy in output capacitance. As shown in Table 1, the reverse recovery charge (Q_{rr}) of new UniFET™ II MOSFET family is dramatically reduced by 50% and 88% compared to alternate solutions.

MOSFET's capacitance is nonlinear and depends on the drain-source voltage since its capacitance is essentially a junction capacitance. In soft switching applications, MOSFET output capacitance can be used as a resonant component. When the MOSFET is turned on, the current that extracted from the magnetizing energy stored in transformer flows to discharge the MOSFET output capacitance in order to allow ZVS condition. Therefore, if stored energy in output capacitance of MOSFET is small, less resonant energy required to achieve soft switching without increasing the circulating energy. The UniFET™ II MOSFET family has approximately 35% reduced stored energy in output capacitance than the same

Table 1:
Critical Specification Comparison of DUT

DUTs	Rds(on)Max	BVDss	ID	Qg	Trr	Qrr
UniFET™ II MOSFET family	0.85 Ohm	500 V	8 A	18 nC	160 ns	1.2 μC
Competitor A	0.85 Ohm	500 V	7.2 A	32 nC	238 ns	2.5 μC
Competitor B	0.70 Ohm	500 V	8 A	45 nC	1200 ns	10 μC

LED MEASUREMENT SYSTEMS

LOW COST • NIST TRACEABLE

Summer SALE
25% OFF SPHERES



6" integrating sphere with 2" input port, internal reflective coating, baffle, and SMA fiber optic output.
Sale Price: \$1300

Watts/m² • Watt Flux • LUX • Lumen
CRI & CQS • Color Purity • CCT
Dominant λ • x, y Chromaticity

12" sphere features a vertical hinge and sample stage with a powered device mounting sockets. Calibration bulb and data file included.

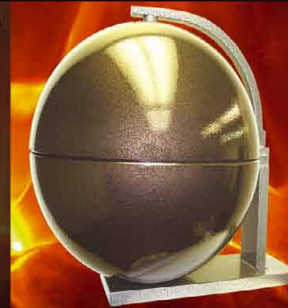

Sale Price: \$2625

StellarNet is a worldwide provider of low cost, rugged measurement systems. All spectroradiometers are NIST calibrated to provide real time absolute intensity measurements. These systems provide reliable and high performance analysis for a multitude of light measurements. Contact us today for a same day quote!

www.StellarNet.us • (+)1-813-855-8687



Figure 2:
Stored energy in output capacitance

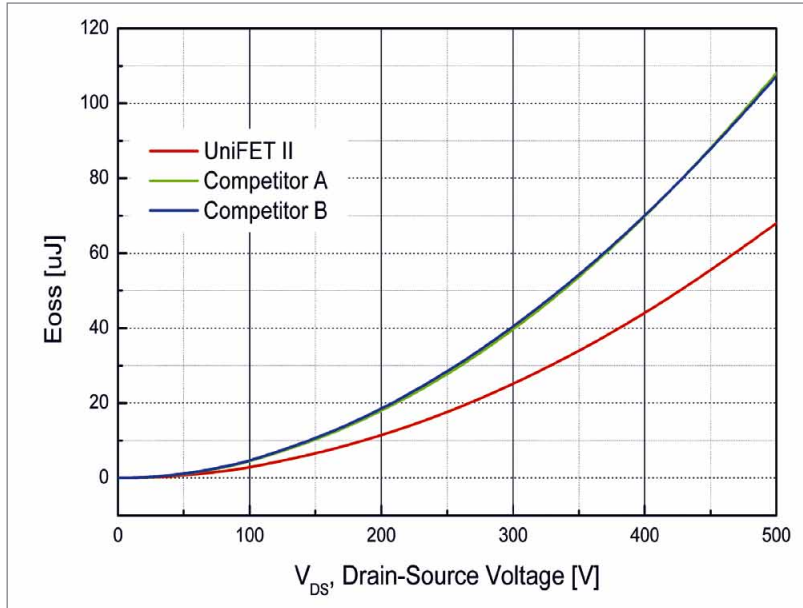

on-resistance competitor’s devices for typical switching power supply bulk capacitor voltage. The benchmark of stored energy in output capacitance is shown in Figure 2.

Benefit to Resonant Converter

The switching process of the diode from on state to reverse blocking state is called reverse recovery. During forward conducting of the diode, charges are stored in the P-N junction of the diode. When reverse voltage is applied, stored charge should be removed to go back to blocking state. The removal of the stored charge occurs via two phenomena: the flow of a large reverse current and recombination. A large reverse recovery current occurs in the diode during the process. In the MOSFET body diode case, some of the reverse recovery current flows right underneath N^+ source. Figure 3 shows MOSFET failing waveforms during body diode reverse recovery. With competitor A, failure happens right after the current level reaches peak reverse recovery current at 6.87 V/ns of dv/dt . It means the peak current triggered parasitic BJT. But UniFET™ II MOSFET family survives in up to even higher dv/dt , 14.32 V/ns.

Figure 3:
Voltage and current waveforms during reverse recovery of body diode:
(a) DUT A
(b) UniFET™ II MOSFET family

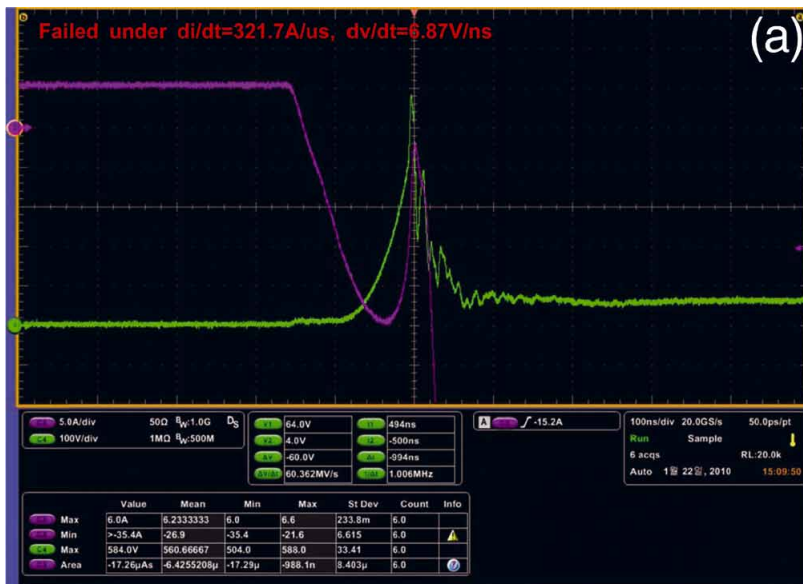
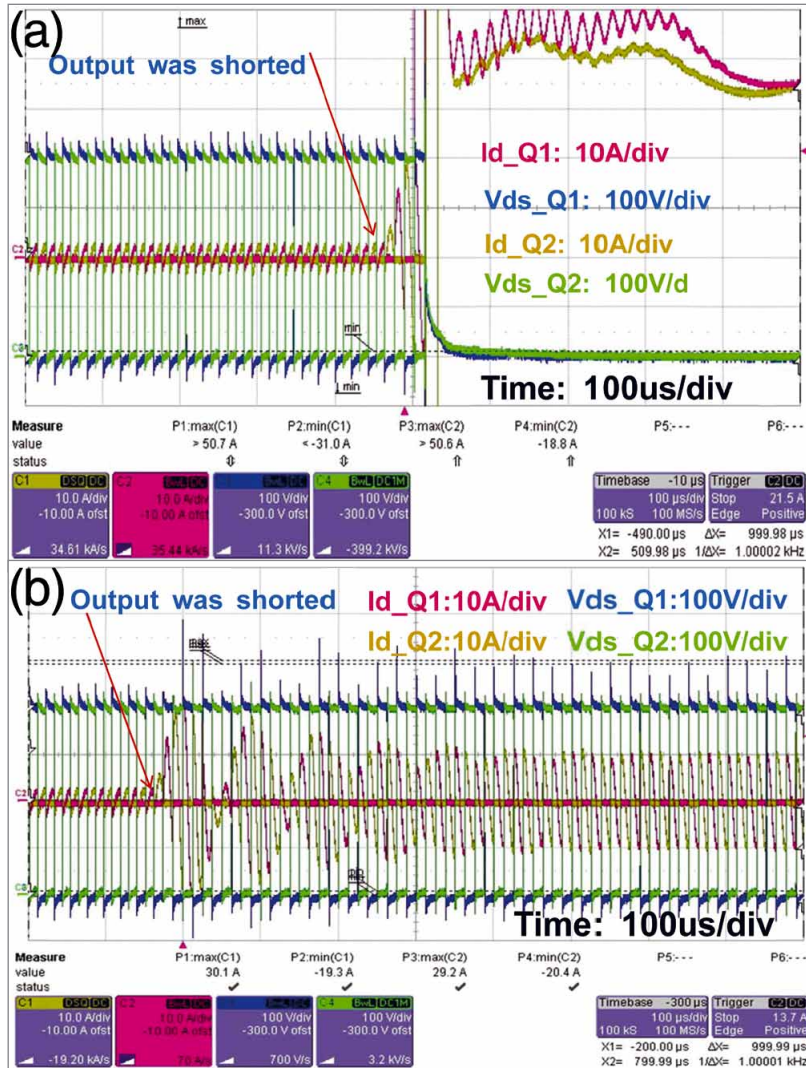

Figure 4 presents how the rugged body diode of UniFET™ II MOSFET family benefits reliability of converter under shorted output. Operation mode is changed from ZVS to ZCS after output short. The current spike of UniFET™ II MOSFET family is much lower due to a smaller Q_{rr} , and most importantly the device does not fail.

The other misbehavior of the converter can happen during the start-up state. Figure 5 shows switch current waveforms at start-up. The high level of current spike, exceeding 27 A, is induced due to big peak reverse recovery current. It can trigger a protection function of control IC. On the contrary, UniFET™ II MOSFET family shows no high current spike.

Figure 4:
Operating waveforms under short circuit conditions:
(a) DUT A
(b) UniFET™ II MOSFET family



In order to compare the power conversion efficiency of UniFET™ II MOSFET family and competitors, a 150 W LLC resonant half-bridge converter is designed. The summary of the efficiency measurements is shown in Figure 6. The system efficiency is higher than competitor MOSFETs for the entire input voltage range. The major reason for higher efficiency is the reduced switch-off loss and output capacitive loss because of lower Qg and Eoss.

Summary

A new power MOSFET family combines rugged intrinsic body diode performance with fast switching, aimed at achieving better reliability and efficiency in resonant converter applications. With a reduced gate charge and stored energy in output capacitance, driving loss is decreased and switching efficiency is increased. The UniFET™ II MOSFET family provides designers better reliability and efficiency at minimum cost. ■

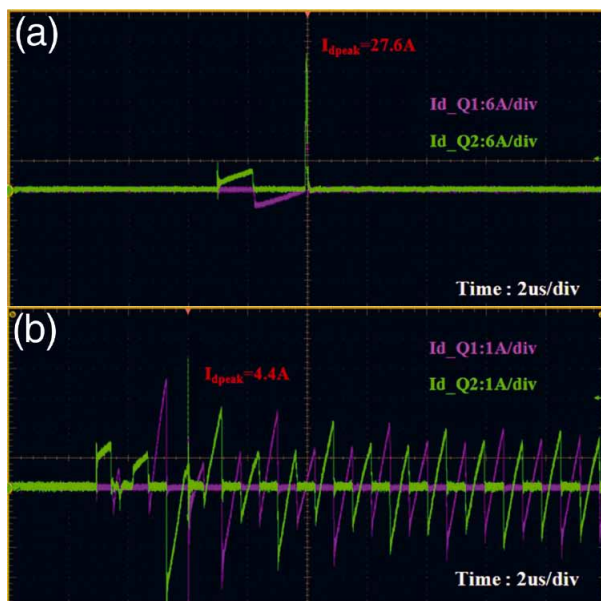

Figure 5: Waveforms at start-up state:
(a) DUT A, (b) UniFET™ II MOSFET family

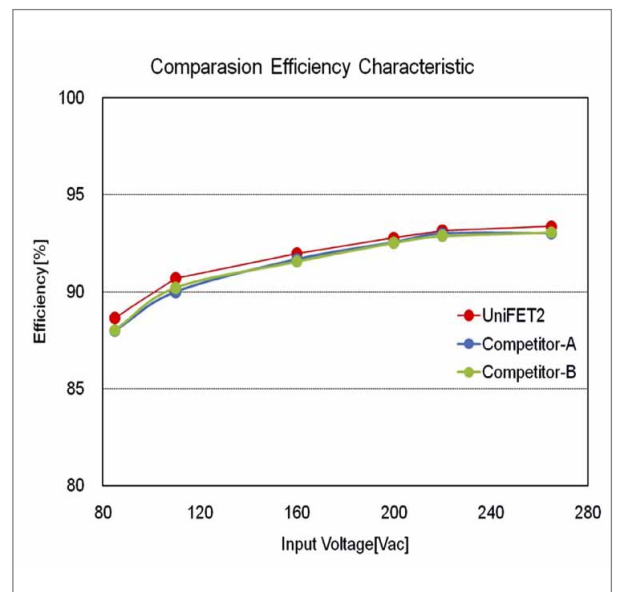

Figure 5: Efficiency comparisons on LLC resonant converter

LED Drivers Help to Make LED Lighting Costs Competitive without Compromising Quality

Steve Roberts from Recom introduces a simple cost effective driver solution for multi-color LED systems and explains what is relevant to allow for a reliable and durable driver design.

At the recent InterSOLAR exhibition in Munich, there were graphs and projections displayed on many stands showing that photovoltaic systems are finally reaching the cross-over point where the initial investment pays off within a reasonable time and the long term savings covers both running and maintenance costs.

This break-even point has been long reached by solid state lighting systems. The Raleigh City SSL projects have demonstrated that municipal LED lighting is a cost effective alternative to traditional lighting. The Assistant City Manager, Daniel Howe, is quoted as

saying; "The cost effectiveness of LEDs in low-bay lighting is way over the tipping point. Everybody should be installing LEDs in such applications ... we haven't done an LED project yet that hasn't penciled out financially" [1].

The case for large scale LED Installations is undoubtedly proven. Obviously, the maintenance costs are a significant factor in the pay-off calculations. To change a light bulb in a domestic environment is not usually a costly exercise, but to replace municipal lighting is a major investment in staff, machinery and documentation overhead.

The financial case for small scale domestic LED installations is not so clear cut. The initial costs are still very high and although the efficacy (lumens/watt) of LEDs is much better than incandescent bulbs, electricity is relatively cheap. This means that the break-even point is very dependent on the initial cost and any replacement costs. There is also an alternative light source to the LED: the energy saving lamp (ESL) which has similar efficacies but costs much less.

The graph below illustrates the point if the maintenance costs are restricted to simply running and replacement costs. The costs are based on a typical

Figure 1:
Running and maintenance costs for lamp types in a typical domestic environment

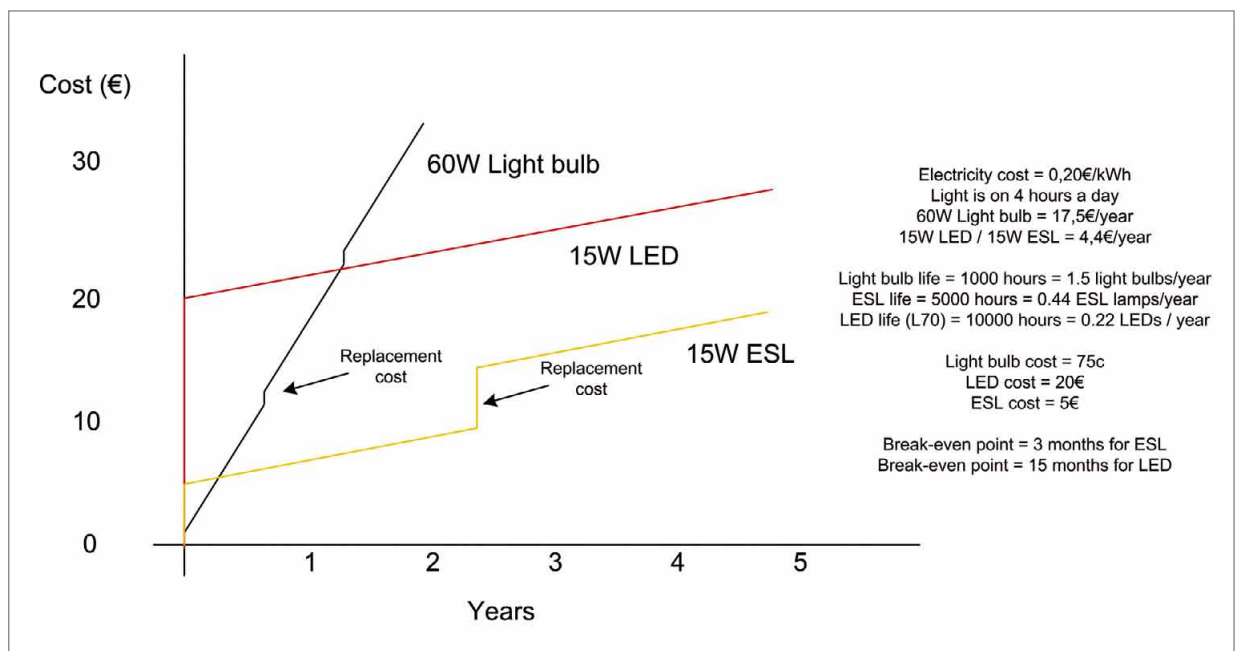

domestic usage of 4 hours per day and compare a 60W incandescent bulb with a 15 W ESL and a 15 W LED. The tipping point for the ESL is only 3 months compared to a light bulb, but the LED takes over a year to pay itself back. As the running costs for both LED and the compact fluorescent are the same, the LED never breaks even compared with the ESL based on electricity costs alone.

Drivers Need to Match LED Lifetime

I have seen other calculations that have similar results. Most of them conclude that at some time in the future, LEDs will eventually outperform all alternatives financially because the lifetime of the LED is so long. David Cox from CREE estimates that the tipping point is around 10 years compared to other lighting technologies and my calculation supports that view. However, this assumes that the LED driver electronics last as long as the LED. Many LED drivers come with the standard statutory guarantee of only 1 or 2 years and if the electronics fail early, the tipping point will never be reached. Using a low cost, low quality LED driver is therefore a false economy. Only a few companies offer an extended warranty up to five years on their LED power supplies; based on 24/7 use and elevated operating temperatures. For instance RECOMs brand new 12, 20 and 30 Watt AC/DC drivers are designed for an amazing

long lifetime of 70,000 or more hours. At 8 hours of daily use this represents a life span of 24 years.

Color Temperature Affects how We “Feel” Light

The color temperature and the width of the color spectrum are big factors affecting the feeling of ease created by a light source. The light source with the most natural feel is the sun as we have evolved with this as our primary light source. Sunlight has a wide spectrum as the white light is literally made up of all the colors in the rainbow. Thus sunlight has a perfect color rendering index (CRI) of 100 as any colored object lit by sunlight shows its true color. On the other hand, the light generated by an open fire feels very natural and pleasant, although it has a much warmer (redder) color temperature, similar to morning or afternoon sunlight. Incandescent bulbs are near-ideal black-body radiators and combine both aspects; a warm white color temperature and a wide spectrum to give a near perfect CRI of 95-100. Thus the humble, inefficient incandescent light bulb gives a very high light quality as any CRI value above 80 is perfectly acceptable in most domestic environments.

ESL lamps work by generating UV light and then converting this to a white light via a phosphor. The most efficient ESL lamps deliver a cold (blue-green) white light. The downside of this high lumens-per-watt phosphor is a CRI of

only around 50 as the light spectrum is very unbalanced. It is possible to combine phosphors (e.g. tri-phosphor fluorescents) to generate a wider spectrum of warm white light, but the spectrum is choppy and misses many wavelengths, so it is still not a comfortable light to work under for long periods of time. Many LEDs also use the same technique of using a phosphor to convert UV into visible light, but have the advantage that different colored LED elements besides the UV dies can be incorporated within the LED assembly to adjust the CRI back closer to 100. An example of this is the Brilliant Mix technique used by Osram in its Oslon LED which mixes red light to a greenish-white phosphor to create a very warm color temperature of 2,700 K yet offers a CRI of up to 98.

Indeed, the whole concept of a tune-able color white light offers some very interesting prospects. We are most active at noon time when the sun is highest in the sky and we relax during the evening when the sun is low on the horizon. Productivity can thus be enhanced by changing the color temperature to the same as high noon (5,000 K) for periods of high activity while reducing the color temperature to evening light (2,700 K) during rest periods to allow people naturally to recover and de-stress. The same concept could be extended to a windowless working environment where the light color temperature could be adjusted to match the diurnal variation of sunlight to give workers a natural feeling of time passing.

The technical barriers to a tune-able white light are not high. Any light color can be generated by using red, green and blue LEDs and adjusting the relative power of each LED. A smart driver design allows a simple circuit that uses only one LED driver and three transistors to create any desired light color [2]. For a tunable natural white light, only two channels are needed: one for the green-white LED and one for the red LEDs. The block diagram circuit below shows how this could be realized using simple off-the-shelf components. In mass production, this could be better

Figure 2:
Block diagram of a tunable white light source using off-the-shelf components

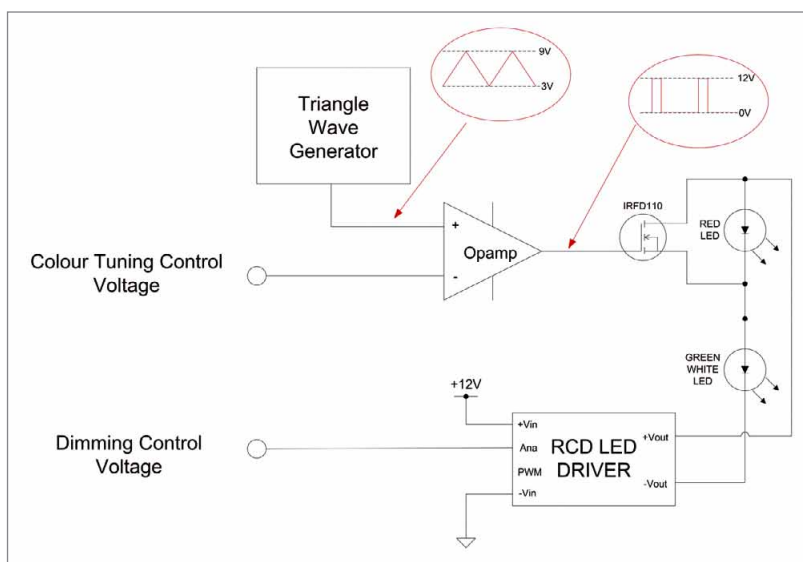

Figure 3:
Well-designed LED drivers which use high quality components guarantee long lifetime and hence lower maintenance costs



realized by having a fixed brightness for the white LED and an adjustable brightness for the red LEDs as a function of the LED driver electronics.

Choosing the right LED lamp and driver thus gives us the advantages of improving on the quality of light delivered by an incandescent or an

ESL. Compact fluorescents are still cheaper in the short run, but deliver a poorer light quality and are not so easily recyclable. And as ESLs contain mercury vapor, they cannot meet the RoHS requirements and can only be sold because they have an exemption. The whole point of the RoHS legislation is to remove all hazardous

chemicals from the environment, thus it is likely that after 2015 when all incandescent lamps are withdrawn from the market for reasons of poor efficiency, that ESLs will also be targeted to be phased out for reasons of environmental health.

Conclusion

The challenge for LEDs is not just to offer a 1:1 replacement for incandescent bulbs or just a cost-effective alternative to ESLs, but to build on the fact that LEDs can offer a much better light quality at a reasonable cost. Combined with innovative, reliable and adaptive LED driver electronics, solid state lighting can create a much more natural light than either alternative. ■

References:

- [1] LEDs Magazine, June 2011
- [2] RECOM RCD24 datasheet



The 13th annual OLEDs World Summit will unite more than 100 OLEDs experts from around the globe for an in-depth look at the industry.



LEDs

OLEDs WORLD SUMMIT 2011

September 26-28, 2011
Hotel Argonaut, San Francisco, CA

Be sure to bookmark and visit www.oledworldsummit.com frequently for speaker and agenda updates.

www.oledworldsummit.com

More than 100 senior-level managers and OLED technologists are expected to attend the conference to discuss the state of the industry, products, applications, manufacturing challenges and more!

Attendees will strategically examine various means to boost OLEDs momentum in both the lighting and displays sectors, and brainstorm on ways to move the industry forward. If you work in the OLEDs industry this is one event you won't want to miss!

OLEDs World Summit
presented in
association with



follow the
conference



@LEDsandOLEDs



OLEDs World Summit

NEW!

Does your driver match the life span of your LEDs?

RECOM's new 3, 6, 12, 20, 30 and 60W AC Input LED Drivers do!

- ✓ Constant current outputs of 0.35/0.5/0.7/1.05 & up to 4.2A
- ✓ Universal AC input voltage (90 to 264VAC)
- ✓ Power factor corrected (RACD12/20/30/60)
- ✓ 3kVAC isolation
- ✓ Fused input and protected output
- ✓ Input and output screw terminals
- ✓ Additional 5.5mm socket output connection
- ✓ Meets UL8750, UL1310, EN61347 & EN55015
- ✓ Design lifetime up to 70.000 hrs (RACD12/20/30/60)
- ✓ 5-year warranty (RACD12/20/30/60)



Introducing the new RACD series - low power AC input LED drivers. RECOM is now offering a low cost solution for low power Solid State Lighting. The series includes 3W, 6W, 12W, 20W, 30W and 60W modules in varying packages capable of driving up to 19 high brightness LEDs or high power arrays.

Building an LED lamp has never been easier!

RECOM LED Drivers are compatible with most LEDs in the industry. We work closely with the leading LED manufacturers to bring to the market the right drivers for the right LEDs.

Typical Applications

- Indoor/Outdoor lighting
- Cabinet lighting
- Recessed lighting
- Fluorescent tube replacement
- LED array modules
- Panel replacement
- Decorative lighting
- Desk lamps
- Freezer lighting
- Landscape lighting
- Theatrical lighting
- Street Lighting

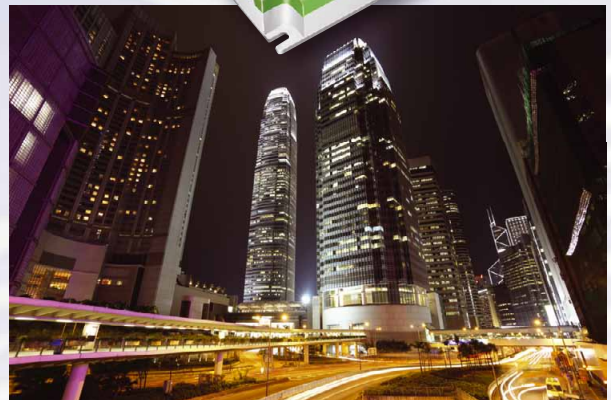

lighting@recom-electronic.com
www.recom-electronic.com

RECOM

LED Driving Techniques to Hit Power Efficiency Targets of TV Backlight Systems

TV manufacturers are struggling with more restrictive power consumption limits for LED-TVs that will be introduced in the next few years to receive the prestigious “Energy Star” certification. Werner Schögler, Markus Luidolt, Manfred Pauritsch and Peter Rust, Design Engineers at austriamicrosystems AG will describe how intelligent driving-techniques support display manufacturers in overcoming this challenge.

Because of global environmental pressure, people all over the world have started replacing conventional types of lighting with higher efficiency light sources. In Australia and the EU, governments announced that the sales of traditional incandescent lamps would be prohibited starting in 2010.

According to the California Energy Commission, TV sets today consume around 8-10% of the average home's electricity. This helps explain why energy efficiency has become such an important design parameter for TV manufacturers, who face a marked tightening over the next few years of the amount of power a TV is allowed to consume.

There seems little doubt that LCD technology with LED backlighting is the only viable way to hit the efficiency targets that the authorities are proposing. Plasma has the disadvantage that each pixel is an active light emitter, so power consumption is directly proportional to the number of pixels. HD plasma televisions on average consume around two to three times the power of an LCD display with the same brightness and resolution.

But today's LCD TVs, even those with LED backlighting, are still some distance from achieving the efficiency targets they will face in the coming years. Now new design techniques in LED driver circuits promise to deliver important energy savings that will go a

long way to helping TV manufacturers meet the tough requirements for power consumption.

Changing Requirements of TV Power Standards

The first standard to regulate the on-mode power of TV sets was Energy Star v3, which came out in 2008. Version 4.0 came into effect on 1 May 2010. It reduced the power consumption limit compared to the previous version by about 40%. It also prevented vendors from misleading performance declarations, as it specified the power consumption limit at maximum light output (ie brightest contrast). Version 5.3 takes effect on 30 September 2011, further reducing the power limit. As each specification reduces the amount of power the TV can draw, the design challenge gets tougher, particularly for large screen sizes (Figure 1).

Energy Star (which is voluntary but highly influential) is not the only form of regulation. For instance, the US State of California's Energy Commission introduced its own standard, with limits effective at the beginning of 2011 and 2013. This regulation prevents the sale of TVs in California that do not meet its efficiency specifications.

Figure 1:
Evolution of Power consumption limits for TV sets, including the actual power consumption of 2011 TV sets (LG cinema 3D TVs) which use the mixed backlight technology

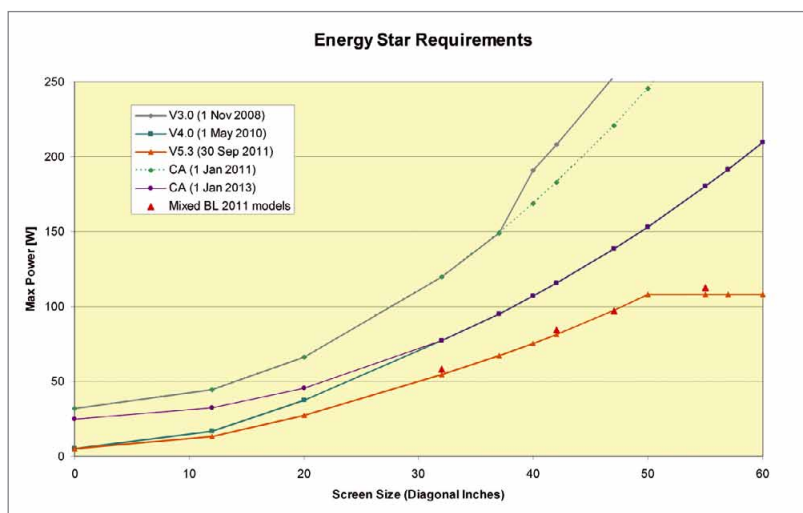

Figure 2 (right): LCD TVs can adopt one of two arrangements for LED backlighting

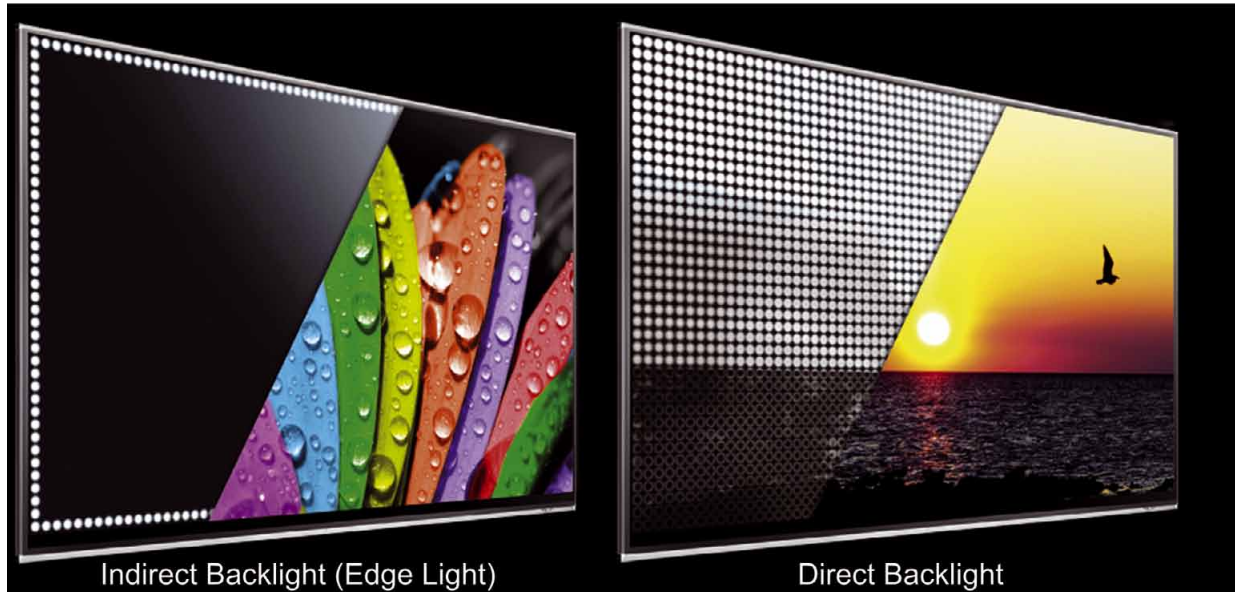

Figure 1 gives a picture of the way the standards have evolved over time and shows the actual power consumption of 2011 TV sets (LG cinema 3D TVs) which use the mixed backlight technology described in this article.

The Operation of LED Backlighting

LED backlight power makes up from 30% to 70% of the overall system power in LCD TVs. Improvements in the efficiency of the backlight power circuit can therefore make a valuable contribution to system efficiency. As is often the case in power system design, a number of small improvements in efficiency can deliver a large combined saving.

There are two ways to implement LED backlighting (Figure 2):

- In indirect backlighting, the LEDs are arranged at the edges of the screen. A light guide distributes the light uniformly across the display. This arrangement can be deployed with good optical uniformity in screen sizes up to 40", and enables backlight units with a thickness of just 5-10 mm.
- In direct backlight systems, the LEDs are located directly behind the LCD, enabling low power, good thermal design and excellent scalability with practically no limit on the screen size. These panels tend to be thicker than edge-lit versions, but with the latest

technologies for light distribution, displays as thin as 8mm can now be found. An important advantage of direct backlighting is that it enables sophisticated local dimming, which lowers power consumption and increases the dynamic contrast ratio.

LED Backlight System Architecture Choices

The first important decision in the design of an LED backlight drive system, and the one with the greatest potential to produce power savings, is over the architecture. As described below, the designer is looking for the best balance between local control of strings of LEDs on the one hand (the more control of individual LEDs, the greater the potential to optimize power consumption), and bill of materials (BoM) costs on the other hand.

Single string and single DC-DC converter

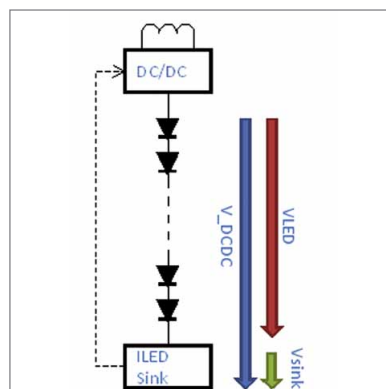

A switched-mode power supply (SMPS, an efficient kind of DC-DC converter) is used to provide the voltage for backlight LEDs arranged in strings. To regulate the current through the LED string, a current sink is included at the end of the string (Figure 3). To minimise power dissipation, the voltage at the ILED sink needs to be a fraction above the voltage necessary to guarantee that the LEDs receive their specified current.

A common design approach is to use a feedback path from the ILED sink to the SMPS to regulate the SMPS' output voltage. This feedback path is required to allow for variations in forward voltage (V_f) from one LED to another – variation which is a natural and unavoidable product of the LED manufacturing process. The typical V_f of a white LED is around 3.2 V, and its variation of V_f is assumed to be at most $\pm 200\text{mV}$ per LED. So, for example, in a string of 10 LEDs, the total for V_{LED} is in the range of 30 V to 34 V.

The voltage required at the DC-DC converter can be expressed as:

$$V_{DC-DC} = V_{LED} + V_{SINK}; V_{LED} = n \cdot V_{f(LED)}$$

V_{SINK} is assumed to be 0.5 V, so the I_{LED} sink must regulate V_{DC-DC} in the range of 30.5 V to 34.5 V, depending on the actual LED forward voltages.

Figure 3: Single string, single DC-DC converter backlight system architecture

Figure 4:
A separate DC-DC converter with each LED string is an expensive option

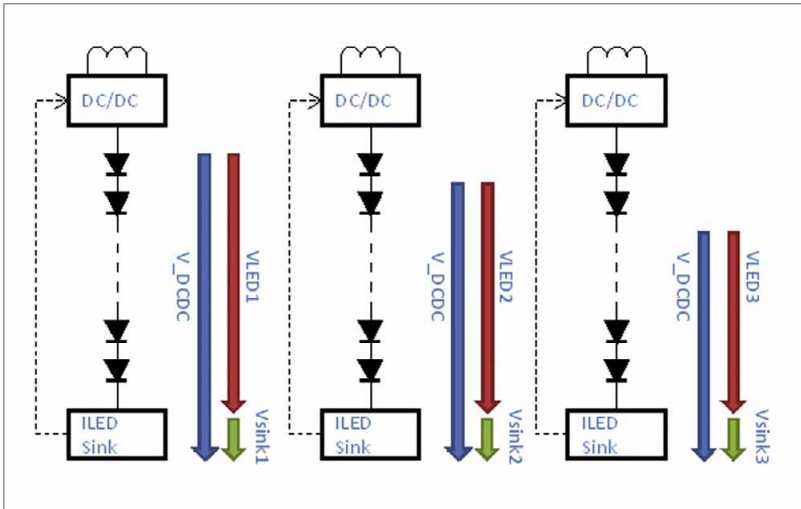

because each string's voltage is regulated separately. The disadvantage is the high BoM cost, because each string requires its own DC-DC controller, MOSFET, coil, diode, and output capacitor. In order to save BoM cost, the designer could reduce the number of LED channels, using long strings with many LEDs in each string. But this then compromises the system's ability to implement local dimming, which is another important power saving technique. So in this topology, none of the trade-offs is particularly attractive.

Figure 5:
With one DC-DC converter serving multiple LED strings, SMPS voltage is not optimized

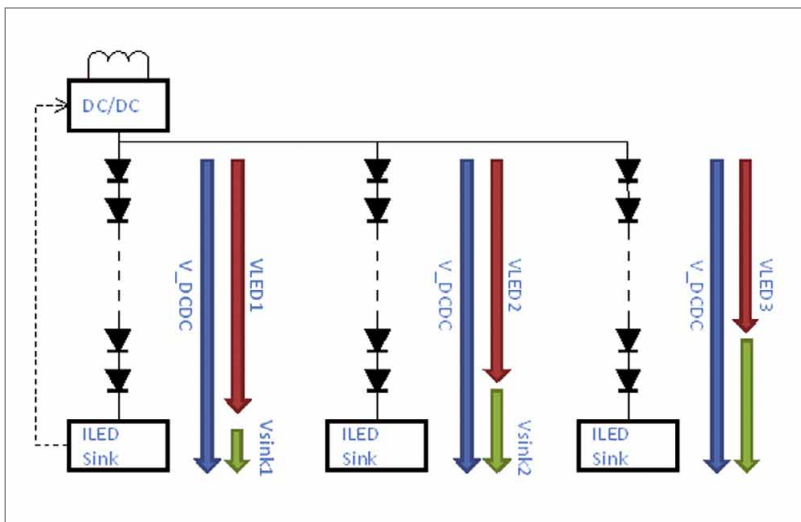

Multi string with single DC-DC converter

A more radical approach to reducing BoM can be found in the multi-string with single DC-DC converter topology (Figure 5). The drawback of this is that the SMPS voltage must be regulated to a point higher than the LED string with the highest forward voltage, which means that it operates at a higher voltage than is necessary for those strings with a lower forward voltage. This in turn means that the ILED sink must dissipate the excess power from the strings with lower forward voltage, generating heat that must somehow be conducted away from the circuit board, and resulting in a decrease in efficiency.

Multi string and multi DC-DC converter

A single string of LEDs is rarely adequate, because as the number of LEDs in the string rises, so the required output voltage rises. Above a certain V_{OUT}/V_{IN} ratio, SMPS efficiency falls dramatically. LED backlight designers

can therefore use several strings in order to avoid an excessive output voltage requirement at the SMPS.

The simplest approach is to duplicate the single string/single DC-DC converter topology at each string (Figure 4). The advantage is efficiency,

Multi string mixed architecture

The architecture that provides the best balance between efficiency and BoM cost is one that combines elements of the multi string and multi DC-DC

Figure 6:
Mixed architecture enables the BoM and efficiency balance to be optimized

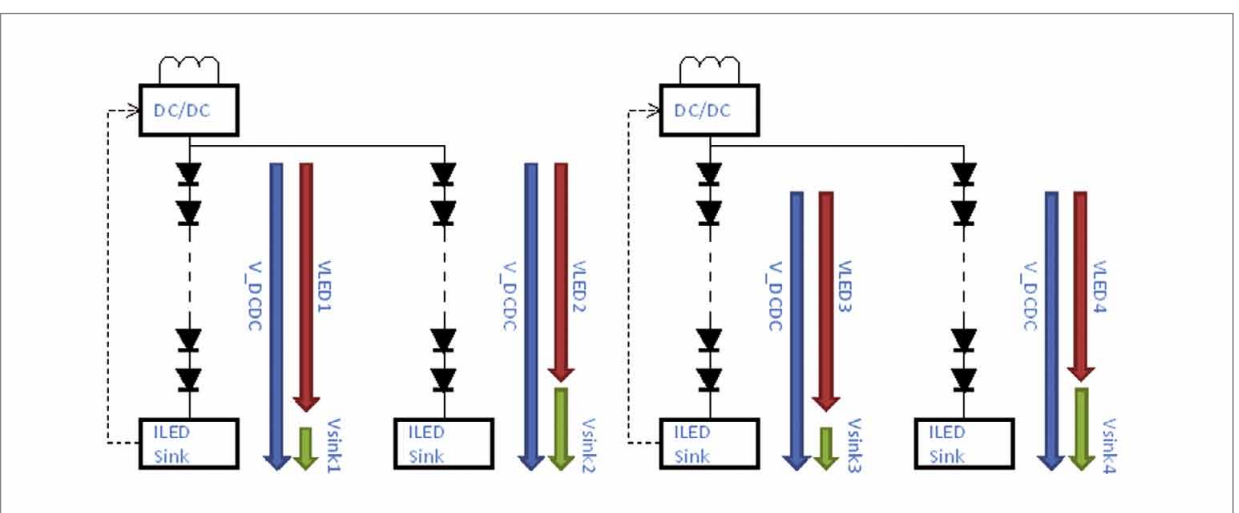

converter architectures described above. This mixed architecture (Figure 6) has multiple DC-DC converters supplying groups of LED strings.

This solution offers the best power consumption because it can combine the advantage of local dimming in direct backlight systems with good DC-DC output voltage regulation. Figure 1 shows the effectiveness of this topology in 2011 TV models (data courtesy of LG, from the specifications for 3D TV models 32LW550S, 42LW650S, 47LW650S, 55LW650S).

At the same time, it offers a substantial BoM saving over the efficient multi string, multi DC-DC converter architecture.

Regulating Current to Match the Characteristics of LEDs

This article has already mentioned the forward voltage variation between white LEDs, a feature of the LED manufacturing process. This same process also causes wide variations in brightness and colour temperature between one LED and another. Therefore, white LED manufacturers allocate each manufactured unit to groups or 'bins' of LEDs with similar performance in terms of colour, brightness and forward voltage.

But the manufacturer's specification for each brightness and colour temperature bin is only valid at a precise nominal operating condition. This means that in order to generate the specified brightness and colour, the LED current must be set to the nominal current stated in the datasheet.

Therefore dimming and brightness control can only be implemented by switching the current to any single LED either to ON (nominal current) or OFF (zero current) through a digital PWM control signal.

In analogue dimming, the LED would be operating outside its specified nominal current, leading to unacceptable changes in colour temperature and poor LED-to-LED brightness matching (Figure 7).

Figure 7:
The brightness of LEDs from the same bin is guaranteed to be perfectly matched only at nominal current (in this case, 20mA)

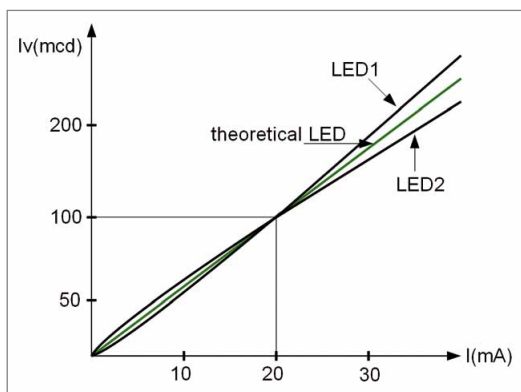

LEDs 2011

Bringing Light to Life

October 24-26, 2011

Hilton San Diego Resort
San Diego, California

Industry experts anticipate new disruptive technologies, changes in regulations and China to play a key factor in the LEDs market in the next several years. IntertechPira's 12th annual **LEDs conference** will once again bring together the leading manufacturers, materials and component suppliers, technology innovators, the lighting community and end users to discuss all the latest market and technological developments and much more. **Don't miss your opportunity to network and learn from this international gathering of the leading companies in the industry!**

"The collective knowledge and insightfulness of the speakers is astoundingly impressive; this conference is a 'must' for anyone in the solid state lighting industry."

CREE

"It's a great way to learn about the industry and meet key players!"

COGNEX CORPORATION

"The presentations, the displays and the attendees offer a wonderful cross-section of this diverse industry. This is a 'must attend' conference."

HONEYWELL

"Good show to get a snapshot of what is going on in the LED space."

DUPONT ELECTRONIC TECHNOLOGIES

Want to raise your company profile with decision makers in the LED and solid state lighting industry? Contact Brian Santos at brian.santos@pira-international.com or +1 207 781 9618 for information about sponsoring or exhibiting.

www.ledsconference.com

Figure 8: Current sink implementations. A precision current sink requires the use of a highly accurate op amp with offset compensation

Current Sink Characteristics

Since LEDs, then, require a perfectly regulated constant-current power supply, it follows that the primary role of the LED driver is to set the current to the nominal value when ON and to 0A when OFF. The feedback loop which is responsible for the accuracy of regulation requires an extremely precise current sink.

While a variety of current sink designs are possible (Figure 8), the precision requirements of TV backlighting (current regulation accuracy of <0.5%) dictate the use of an active operational amplifier to set the ILED current independently of the ILED voltage. This in turn requires a very accurate op amp – a function that is not in itself particularly hard to implement. But in backlight driver applications, the task is made harder because of the requirement to maintain the accuracy of current regulation even when the voltage at the current sink falls to very low levels.

This is a difficult requirement to meet: A range of ultra-accurate current sink LED drivers (e.g. austriamicrosystems' AS369x family) have been designed specifically to operate in such an application. These new devices also incorporate an offset-compensated op amp. Current sink drivers require a minimum voltage at the drain ($V_{DS(sat)}$) to ensure the full accuracy and proper operation of the sink transistor inside the saturation region. For the saturated region, the output current is mainly controlled by the gate-source voltage.

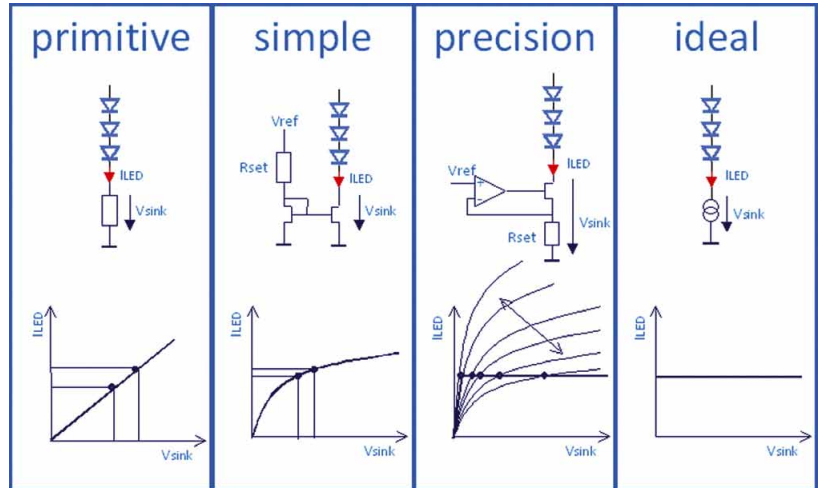

If the current sink is to operate at high efficiency, it is important that the voltage drop between V_{SET} and V_{DS} is low. LED drivers with op amps that include built-in offset cancellation can maintain V_{SET} at levels as low as 125-250 mV. Allowing an additional margin for V_{DS} above $V_{DS(sat)}$ of 150 mV, in total a drop at the current sink of around 400 mV is necessary. For a string of eight LEDs, (where $V_f = 8 \times 3.2 = 25.6$ V) this means a power loss of around 1.5% in I_{SINK} . Without the offset cancellation included in these backlight LED drivers, the value of V_{SET} would be higher, leading to higher power losses at the current sink.

Feedback regulation for power optimization

As has been shown above, then, a feedback path from the LED driver to the SMPS sets the drain voltage to the minimum required value. The output current sink can either be implemented with a simple, defined current output

driver and an external capacitor (Figure 9, left-hand diagram) or with a digital control circuit which sets attack/release times and controls the current output with a digital-to-analogue converter (IDAC) (Figure 9, right-hand diagram).

Both of these solutions offer good efficiency, work with every type of SMPS with voltage feedback, and can be implemented by attaching feedback lines from more than one driver to the same SMPS, as is required in mixed-architecture systems.

However, the second digital implementation provides some special advantages. As well as requiring no output capacitor, the digital circuit also gives the designer the freedom to define the feedback system's attack and decay times. By selecting a fast attack time combined with decay latency and relatively slow decay, the display's performance can be improved.

Figure 9: Different methods for implementing a feedback loop to the SMPS

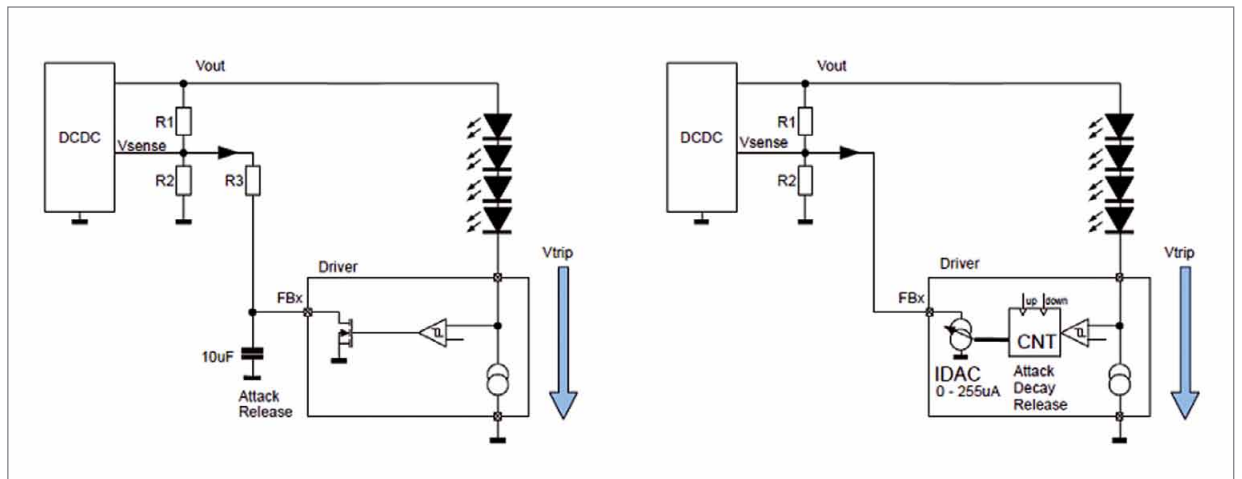

Lighting Fair 2011

LED/OLED Lighting Fair 2011

September **21**(Wed) - **23**(Fri), 2011 | **coex**, Seoul, Korea

Organized by Korea Institute of Lighting Technology(KILT)
The Korean Institute of Illuminating and Electrical Installation Engineers(KIEE)

Managed by Exporum

Exhibit Profile

- Lighting Application
- Lighting Products
- Lighting Design
- Lighting Systems and Services
- LED/OLED Lighting Devices
- LED Components and Material
- LED Manufacturing and Testing Equipment

Exhibition Scale 200 Exhibitors from 10 Countries
30,000 Visitors

Application Deadline Aug. 31(Wed), 2011

Contact Us

LIGHTING FAIR 2011 Secretariat Tel. +82-2-6000-6676, 2051-3322 Fax. +82-2-2051-3326 E-mail. Lighting@lightingfair.co.kr

Concurrent Events

- Awards Ceremony of Lighting Fair 2011
- International Lighting Technology Conference
- Business matching Service



This benefit is particularly noticeable in scenes that require the brightness to change rapidly. A fast attack time eliminates perceptible brightness artefacts as the screen changes from dark to full brightness. An analogue solution (Figure 10, left) dims the LEDs' output gradually during a short dark frame, resulting in a visible delay in achieving full brightness for the ensuing bright frame.

This is a quite noticeable distraction for TV viewers when films create large dynamics from one frame to another. Such artefacts can be eliminated in digital regulation circuits, by inserting latency in the range of several hundred milliseconds into the decay instruction. This means that, where bright frames are interrupted by a short sequence of dark frames, the second bright frame starts at full brightness, because the driver has automatically delayed the voltage ramp-down. Digital feedback algorithms implementing decay latency can only be found in the most advanced and most recent products.

Another useful feature integrated in LED driver ICs is a fast Serial Peripheral Interface (SPI). In direct backlit TVs, the LEDs are arranged in a large number of relatively short strings, so that small areas of the panel can be dimmed. Typically, such arrangements contain 256 channels in a 16x16 fields matrix, each individually configured through pulse width modulation (PWM). But generating 256 PWM signals with variable PWM width and delay is a hugely intensive processing task even for the fastest microcontroller.

Therefore, these backlight systems use local PWM generators integrated into the LED driver ICs. This enables brightness to be configured with simple SPI data transfers. In an architecture with multiple driver ICs (eg 256 channels with 16 channels per IC, and 16 ICs), the LED channels can be configured by daisy-chaining SPI signals and transferring the data that are used in a VSYNC frame to the frame before (Figure 11).

In this arrangement, data transfer over SPI can reach speeds of 20 Mb/s, or 50 kb/frame at a 400 Hz frame rate. With latency made up of just the delay, high time and the period for local PWM generation, this is fast enough to change dimming of each field in sync with the actual frame. So ideal local dimming results can be achieved with minimum overhead on the microcontroller.

Smart dimming for edge-lit systems

This local dimming technique is, of course, only possible with direct-backlighting systems. But a certain amount of smart dimming can also be achieved with edge lighting. In particular, PWM dimming can be used to vary brightness without changing the colour temperature of the white LEDs. Instead of having the edge light LEDs permanently set to a specific brightness value, in such a scheme the brightness dynamically changes, via changes to the pulse width, according to the picture content.

Another technique for power saving is Dynamic Luminance Scaling (DLS): with this, the LCD's white level/brightness level is increased in certain scenes to allow the backlight LEDs' power output to be reduced.

Another method to reduce the power consumption is the use of ambient light sensors. If the ambient light (e.g. at night) is dark, the backlight brightness can be reduced. Even more sophisticated methods are being explored by TV manufacturers. For instance, cameras are beginning to be designed into displays, to enable consumers to use video-telephone services such as Skype on their TVs. These cameras can also be used to detect if someone is actually watching TV; if the TV is on without anyone being in the room the backlight can be reduced to a minimum brightness level.

Potentially even customised energy consumption patterns can be implemented: while you might prefer watching in the energy friendly eco-mode with a reduced backlight, another member of the household might prefer full brightness.

Conclusion

Tough regulation is set to limit even further the maximum power that a new TV can consume. By implementing all of the available techniques for efficient LED driving, a considerable contribution to the required power savings can be made, as is shown by the LG 3D TV examples cited in Figure 1. ■

Figure 10: Digital feedback loop (right) enables faster transitions from dark to bright than analogue feedback loop (left)

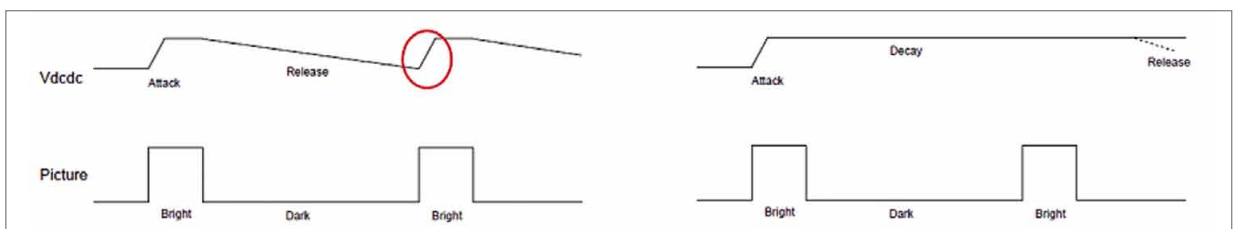
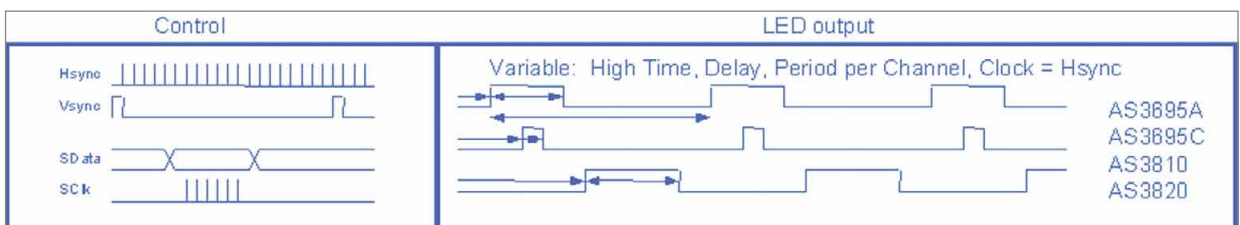

Figure 11: SPI transfer and programmable PWM generators



Bodo's Power Systems®

Your best choice to communicate!

Free subscription on www.bodospower.com

One World,
One Magazine
On Time, Always



Partner with these events:



Imprint

LED professional Review (LpR)
ISSN 1993-890X

Publisher

Luger Research e.U.

Institute for Innovation & Technology
dept. LED professional
Faerbergasse 15, Haus Rot
A 6850 Dornbirn, Austria / Europe

phone +43 5572 394 489
fax +43 5572 394 489 90
editors@led-professional.com
www.led-professional.com

Publishing Editors

Siegfried Luger
Arno Grabher-Meyer

phone +43 5572 394 489
phone +43 5572 394 489-18
editors@led-professional.com

Int. Account Manager

Theresa Koenig

phone +43 5572 394 489-20
theresa.koenig@led-professional.com

Front-page picture

Image: Arno Grabher-Meyer, LED professional, Epistar HF25/HV45 LEDs
Artwork: Thomas Klobassa, ©LED professional 2011

Copyrights – Luger Research e.U.

The editors make every reasonable effort to verify the information published, but Luger Research e.U. assumes no responsibility for the validity of any manufacturers, non profit organisations or individuals claims or statements. Luger Research e.U. does not assume and hereby disclaims any liability to any person for any loss or damage caused by errors or omissions in the material contained herein, regardless of whether such errors result from negligence, accident or any other cause whatsoever. You may not copy, reproduce, republish, download, post, broadcast, transmit, make available to the public, or otherwise use LED professional Review (LpR) content without prior written consent from Luger Research e.U. – Institute for Innovation & Technology, Austria. ■



LED professional Review (LpR) - Annual Subscriptions

LpR Digital Magazine

- 6 issues
- pdf download
- high resolution pictures and graphs
- printable
- commercial use
- access to all previous issues
- Euro 78.80

<http://www.led-professional.com/subscription>

LpR Printed Magazine

- 6 issues
- Euro 158.40

Next LpR Issue - Sept/Oct 2011
Optics, Thermal, Drivers, Events

LED professional

SYMPOSIUM +EXPO

LpS 2011

LED Lighting Technologies

International Winning Approaches

27-29 SEPTEMBER 2011
BREGENZ | AUSTRIA

CONTACT:
LUGER RESEARCH | Faerbergasse 15 | 6850 Dornbirn
T +43 5572 39 44 89 | F +43 5572 39 44 89 90
info@lps2011.com | www.lps2011.com

OSRAM

Opto Semiconductors

AVAGO

TECHNOLOGIES

e:lumix

LED Technologie GmbH

TRIDONIC

enlightening your ideas

SIGN UP NOW!

www.lps2011.com

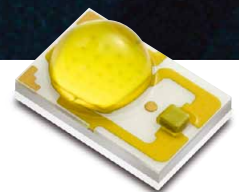

Transforming Light

LUXEON LEDs are changing the way we light the spaces we live, shop and play in. With unparalleled efficiency, quality, and reliability, LUXEON LEDs are a simple way to transform lighting and improve the well being of our environment.

Whether you're lighting a restaurant, roadway or architectural masterpiece, you can count on LUXEON to deliver long life, high-quality white light while reducing energy consumption.

To learn how LUXEON can help you transform lighting, call our partner, Future Lighting Solutions, at +1-888-589-3662, or visit www.philipslumileds.com/transform

LUXEON[®]

PHILIPS
LUMILEDS

LED Z5

For bright moments

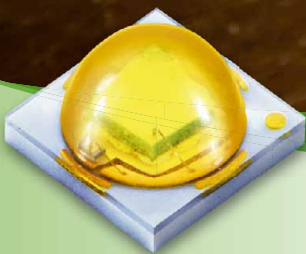

LED Z5: First Lighting Choice – Best Lighting Choice

- CRI 70 - 85
- Optical efficiency 110 lm/W (typ.) @ 350 mA
- Luminous flux 97 ~ 140 lm @ 350 mA, T_j 100°C
- Max. forward current 1200 mA
- All color temperatures available

Seoul Semiconductor: Tel. +49 (89) 450 36 90 - 0



SEOUL SEMICONDUCTOR

Worldwide leading LED-Manufacturer

www.seoulsemicon.com